

EMCO[®]
WHEATON RETAIL

**Multi-Port Phase I EVR System
Executive Order VR-105**



Affordable • Watertight • Serviceable • Compliant

A1004EVR Multi-Port Spill Containment

Guide Specification:

- 42-inch steel diamond plate lid with 16-inch tank bung spacing
Optional diamond plate lid in light weight aluminum
- 6 cam-locks and dual lid handles for easy lock-down and removal
- 8-inch observation port w/ water tight seals
- All mounting bolts non-corrosive stainless steel
- Manhole rim channel w/ D-seal for water tightness integrity between lid and rim
- Manhole available w/ 12-inch or 18-inch galvanized skirt
- Nominal spill container capacity of 5 US gallons
- Cast iron spill container base w/ 4-inch NPT thread connection
Requires no face seal adapter
- Powder coated, heavy duty, cast iron lid and ductile iron plow ring, exceeds DOT H-20 loading
Optional lid in composite material
- Lid w/ triple wiper seal
- HDPE primary spill container bellows
- Drain valve w/ filter or plug option
- Compatible with most water shrouds and boot kits

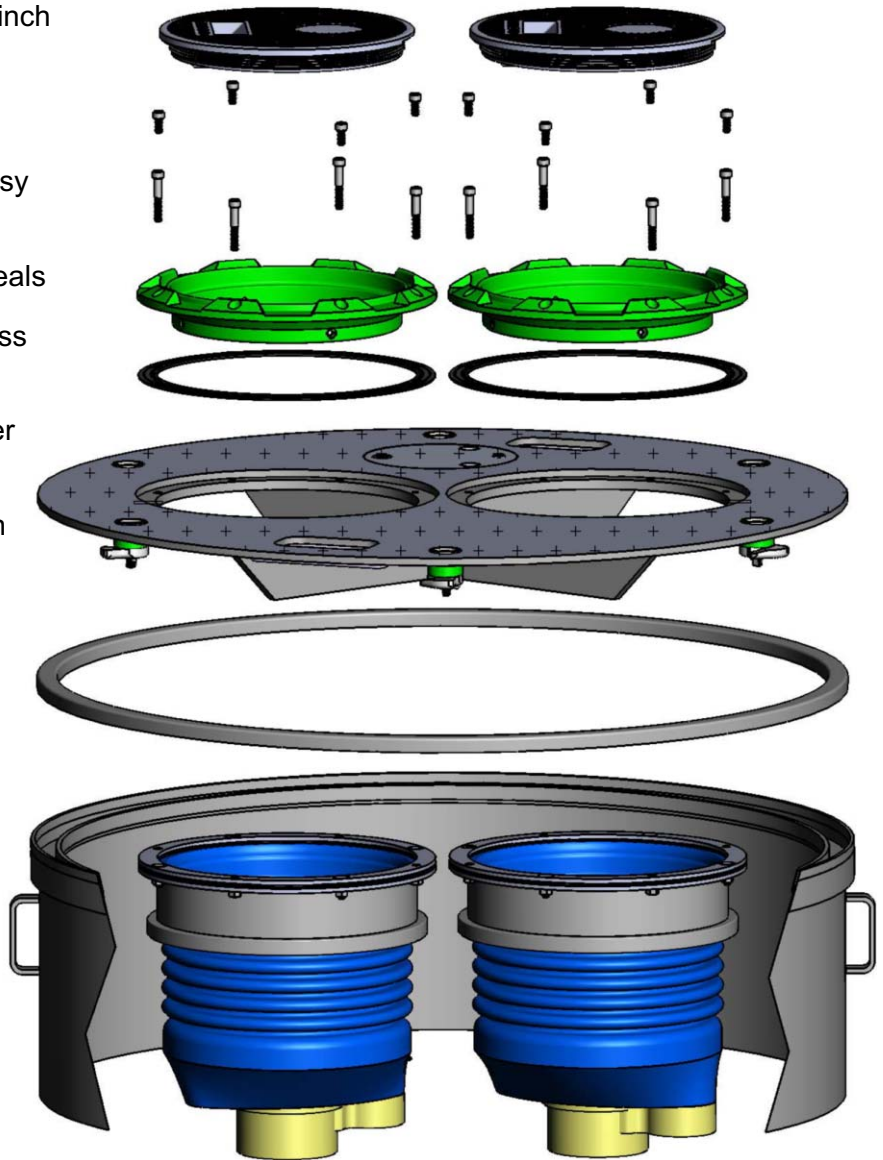

Model No.	Description	Spill Container #1	Drain Type	Spill Container #2	Drain Type
A1004EVR-242-1D1A	42" Multi-Port MH, 8" Observation Port 12" Skirt, Gasoline	SW, 5 gal	Drain Valve	SW, 5 gal	No Drain
A1004EVR-242-11A	42" Multi-Port MH, 8" Observation Port 12" Skirt, Gasoline	SW, 5 gal	No Drain	SW, 5 gal	No Drain
A1004EVR-242-1D0A	42" Multi-Port MH, 8" Observation Port 12" Skirt, Diesel	SW, 5 gal	Drain Valve	None	N/A
A1004EVR-242-10A	42" Multi-Port MH, 8" Observation Port 12" Skirt, Diesel	SW, 5 gal	No Drain	None	N/A

Custom configurations are available upon request



A1100EVR Overfill Prevention Valve

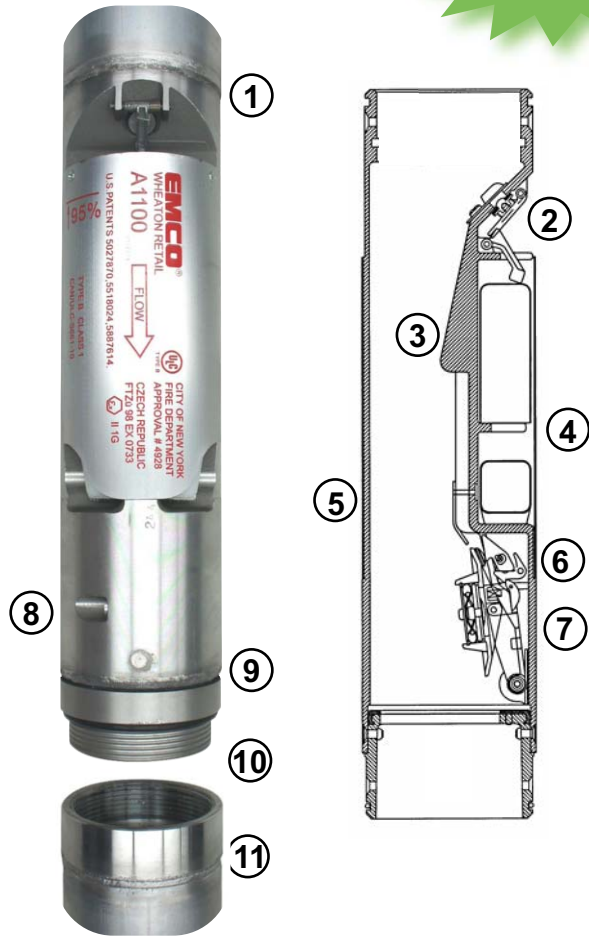

Guide Specification:

- 1 Upper drop tube to valve body factory welded
- 2 Bleed valve drains fuel delivery hose after 95% shut-off
- 3 Diverter fins protect flapper valve during routine “tank stick” gauging
- 4 Top and bottom floats contained in protective sleeve to insure damage-free installation and removal from tank fill riser
- 5 Die cast aluminum valve body design provides the highest delivery flow rate
- 6 Spring loaded reset function opens flapper valve and allows for immediate “tank stick” gauging
- 7 Flapper valve provides positive fuel shut-off at 95% total storage tank capacity
- 8 External field test port allows for manual routine testing of flapper valve
- 9 Lower drop tube to valve body factory welded
- 10 Valve body to male coupling factory welded
- 11 Female coupling to lower drop tube factory welded
 - Materials and seals are compatible with up to E25 ethanol blend gasoline and B20 biodiesel blends
 - Factory tested for operability and vapor tightness integrity
 - The A1100EVR OPV is not recommended for underground storage tanks under 6.5 ft in diameter

Model No.	Overall Length	Max. Riser Length	Nominal Tank Dia.	Weight
A1100EVR-055	14.0 ft.	4.6 ft.	8 ft.	22 lbs.
A1100EVR-056	16.0 ft.	5.5 ft.	10 ft.	24 lbs.
A1100EVR-057	18.2 ft.	6.2 ft.	12 ft.	27 lbs.
A1100EVR-058	21.7 ft.	9.5 ft.	12 ft.	30 lbs.



A0020EVR
Rolled Edge Collar



A0020EVR
Heavy Duty Collar

A0020EVR Straight Drop Tube

Guide Specification:

- 4-inch diameter aluminum construction
- Available standard rolled edge or heavy duty collar
- Installs on a typical 4-inch tank fill riser for below ground storage tanks

Model No.	Model No.	Overall Length
Rolled Edge Collar	Heavy Duty Collar	
A0020EVR-004	A0020EVR-004	12'
A0020EVR-005	A0020EVR-005	15'
A0020EVR-007	A0020EVR-007	17'
A0020EVR-008	A0020EVR-008	14'

Phase I EVR Components



A0097-005
Fill Adapter Cap



A0099-002
Vapor Adapter Cap



A0097-010
ATG Probe
Adapter Cap

Guide Specification:

- Top-seal cam and groove design for vapor tightness integrity
- Aluminum body powder coated orange or gray for field identification
- Lockable toggle action aluminum handle with self-aligning cams
- The Model A0099-003 includes a 12-inch chain to prevent theft
- The Model A0097-010 includes cord grip for use with ATG probes
- A0097-010A includes ATG probe cap and adapter



A0030-124S
Swivel Fill Adapter



A0076-124S
Swivel Vapor Adapter



A0030-014
ATG Probe Adapter

Guide Specification:

- A 360 degree rotation prevents accidental loosening from 4-inch tank fill or vapor riser
- Brass construction cam and groove design for use with top-seal caps for vapor tightness integrity
- Flat gasket with 4-inch NPSM thread connection
- The Model A0076-124S available with a normally closed poppet
- The Model A0030-014 is non-swivel for use with ATG probes
- Allows for complete field serviceability should the swivel adapter fail CARB static torque TP-201.B, leak tightness integrity tests TP-201.D or TP-201.3



494096 Riser Seal

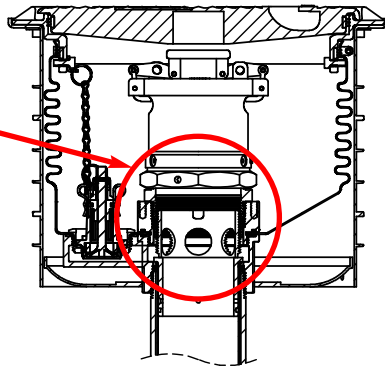

Guide Specification:

- Lowers the top of the drop tube collar below the spill containment drain valve path
- Two-piece stainless steel construction



A0075
Ball Float



A0079 Extractor
Cross Fitting



A0079 Extractor
Tee Fitting



A0179
Extractor Cage



A0279 Extractor
Test Plug