

# A1004EVR-210/211 Series Single/Double Wall Poly Spill Containment

## Specifications

- Replaceable; easily repair or replace primary & secondary units from grade without breaking concrete

- 5 gal capacity
- Single wall (A variants) or double wall (S variants)

- Weights: SW Lid 20 lbs, Total: 86 lbs  
DW Lid 20 lbs, Total: 104 lbs

## Materials

- Cast iron rim
- Cast iron water-resistant lid, built-in handle & exclusive triple wiper seal
- HDPE bellows

## Application

- Grade level
- 4" NPT or BSPT Screw-on

## Components

- Liquid Sensor
- Drain

## Approvals

- Phase I EVR Executive Order VR-105
- ULC Listed MH21149
- FL DEP # EQ-594 5 gal., #EQ-695 15 gal.
- NC DENR
- MO DNR
- Lid meets H20 Load Rating

## Color Variant Part Numbers

Model No.	Rim/Lid	Drain	Sensor/Gage	Thread
A1004EVR-210A	Black	Yes	N/A	NPT
A1004EVR-210AB	Black	Yes	N/A	BSPT
A1004EVR-210S	Black	Yes	EZ-Gage	NPT
A1004EVR-210S-CM	Black	Yes	Sensor	NPT
A1004EVR-210SX*	Black	Yes	EZ-Gage	NPT
A1004EVR-211A	Black	No	N/A	NPT
A1004EVR-211AD	Black	Plug	N/A	NPT
A1004EVR-211S	Black	No	EZ-Gage	NPT
A1004EVR-211S-CM	Black	No	Sensor	NPT

\*Includes A0030-124S Fill Swivel Adapter & A0097-005 Fill Cap

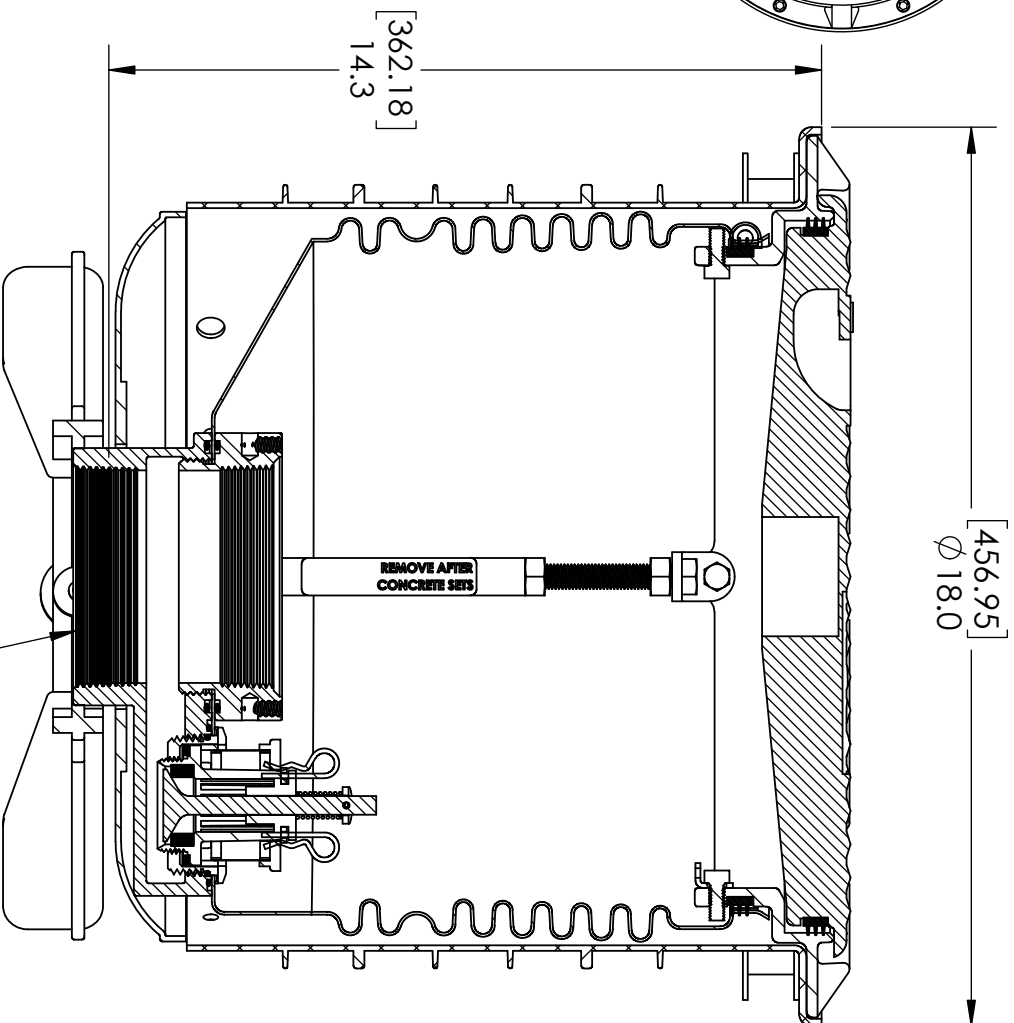
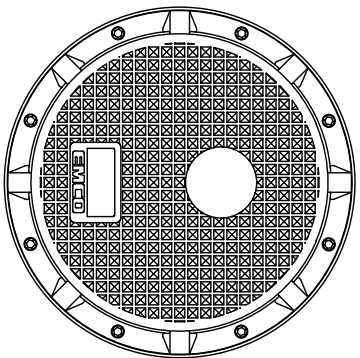

**EMCO**® EMCO WHEATON RETAIL CORPORATION  
2300 INDUSTRIAL PARK DRIVE  
WILSON, NC 27893

**DO NOT SCALE DRAWING-WORK TO DIMENSIONS SHOWN**

DIMENSIONS ARE IN INCHES (DIMENSIONS IN BRACKETS ARE IN MILLIMETERS)

UNLESS OTHERWISE SPECIFIED

DECIMALS	ANGLES	DRAWN BY	DATE	USED ON	PART NAME	SYM	REVISIONS	DATE	BY
X ± .030	XX ± .015	XXX ± .005	± 1°	GEB	8/2/19				GEB
CASTING TOLERANCES TO INDUSTRY STANDARDS MACHINED SURFACES 1.25 RMS REMOVE ALL BURRS		CHECKED BY	DATE	PROJECT NUMBER					
		APPROVED BY	DATE	SCALE	WEIGHT				
		MATERIAL			CASTING NUMBER				
		SEE NOTE							
SW 5 GAL SPILL CONT. W/EVR DRAIN, 4" THREAD						SIZE	DRAWING NUMBER	PAGE	REV
A						A1004EVR-210A	1 OF 1	A	

THE INFORMATION AND DESIGN DISCLOSED BY AND THE COPYRIGHT IN THIS DRAWING ARE THE PROPERTY OF EMCO WHEATON RETAIL CORP. AND CANNOT BE USED WITHOUT WRITTEN PERMISSION.