

# A1004EVR-215/216 Series Single/Double Wall Poly Spill Containment

## Specifications

- Replaceable; easily repair or replace primary & secondary units from grade without breaking concrete
- 15 gal capacity
- Single or double wall
- Weights: Lid 15.9 lbs, Total: 98.3 lbs.

## Materials

- Cast iron rim
- Cast iron water-resistant lid, built-in handle & exclusive triple wiper seal
- HDPE bellows

## Application

- Grade level
- Installs 16" on center
- 4" NPT or BSPT Screw-on

## Components

- Liquid Sensor
- Drain

## Approvals

- Phase I EVR Executive Order VR-105
- ULC Listed MH21149
- FL DEP # EQ-741 5 gal., #EQ-695 15 gal.
- NC DENR
- MO DNR
- Lid meets H20 Load Rating

## Color Variant Part Numbers

Model No.	Rim/Lid	Drain	Sensor/Gage	Adapter
A1004EVR-215S	Black	Yes	EZ-Gage	N/A
A1004EVR-215S-CM	Black	Yes	Sensor	N/A
A1004EVR-216A	Black	Yes	N/A	N/A
A1004EVR-216SJ	Black	No	N/A	N/A
A1004EVR-216SJ-D	Yellow	No	N/A	N/A
A1004EVR-216SJ-R	White	No	N/A	N/A
A1004EVR-216SJ-U	Red	No	N/A	N/A

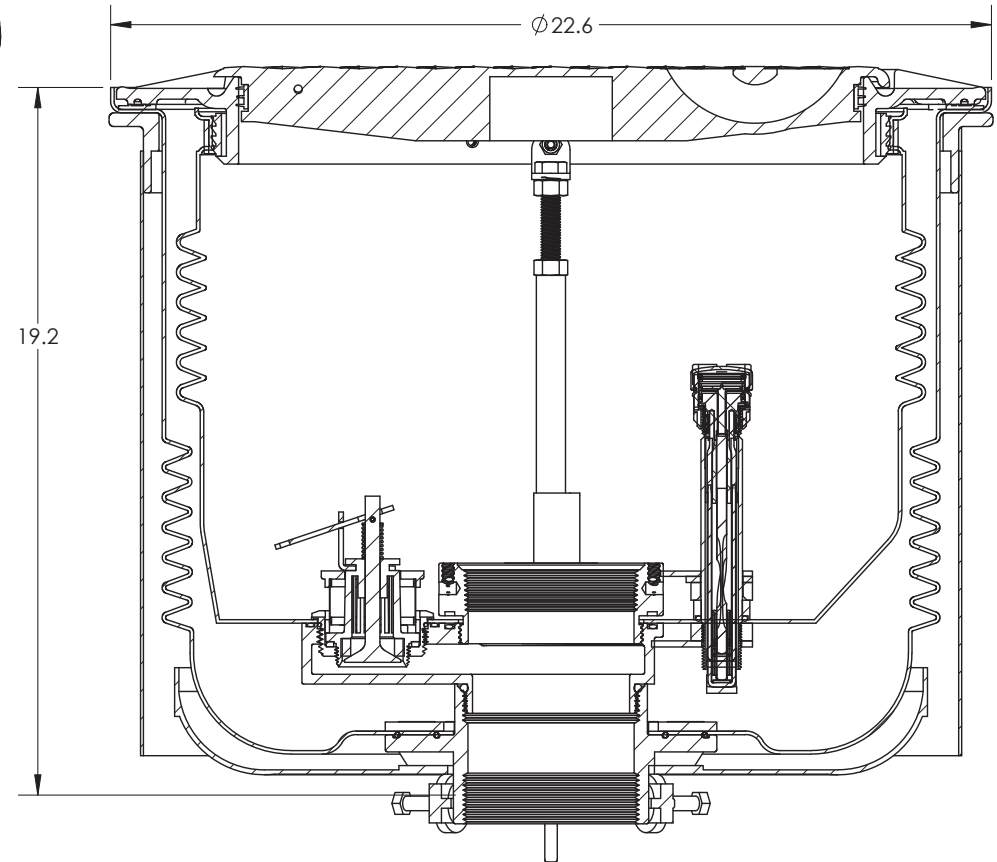
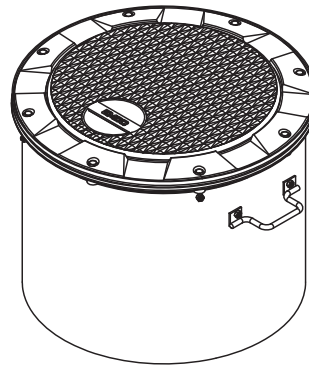

EMCO WHEATON RETAIL CORP.  
2300 INDUSTRIAL PARK DRIVE  
WILSON, N.C. 27893  
emcoretail.com

**DO NOT SCALE DRAWING-WORK TO DIMENSIONS SHOWN**  
DIMENSIONS ARE IN INCHES (DIMENSIONS IN BRACKETS ARE IN MILLIMETERS)

UNLESS OTHERWISE SPECIFIED  
DECIMALS .X ± .030 .XX ± .015 .XXX ± .005 ANGLES ± 1°  
CASTING TOLERANCES TO INDUSTRY STANDARDS  
MACHINED SURFACES 125 RMS REMOVE ALL BURRS

THE INFORMATION AND DESIGN DISCLOSED  
BY AND THE COPYRIGHT IN THIS DRAWING  
ARE THE PROPERTY OF EMCO WHEATON  
RETAIL CORP. AND CANNOT BE USED  
WITHOUT WRITTEN PERMISSION.

DRAWN BY	DATE	USED ON	CASTING NUMBER
NPC	10/11/17		

SYM	REVISIONS	DATE	BY

PART DESCRIPTION  
DW SPILL 15GL W/DRN

SIZE	DRAWING NUMBER.	PAGE	REV.
A	A1004EVR-215S	1/1	B