

# A1005-518FDX

## Double Wall Stainless Steel Spill Containment

### Specifications

- Replaceable; easily repair or replace primary & secondary units from grade without breaking concrete
- 5 gal capacity
- Double wall
- Weights: Lid 15.9 lbs, Total: 98.3 lbs

### Materials

- Cast iron rim
- Cast iron water-resistant lid, built-in handle & exclusive triple wiper seal
- Stainless steel primary/secondary

### Application

- Grade level
- Installs 16" on center
- 4" NPT Screw-on

### Components

- Sensor ready
- Drain

### Approvals

- Lid meets H20 Load Rating

### Color Variant Part Numbers

Model No.	Rim/Lid	Drain
A1005-518FDX-CMR	Black	Yes
A1005-518FDXCRM-D	Yellow	Yes
A1005-518FDXP-CRM	Black	Plug

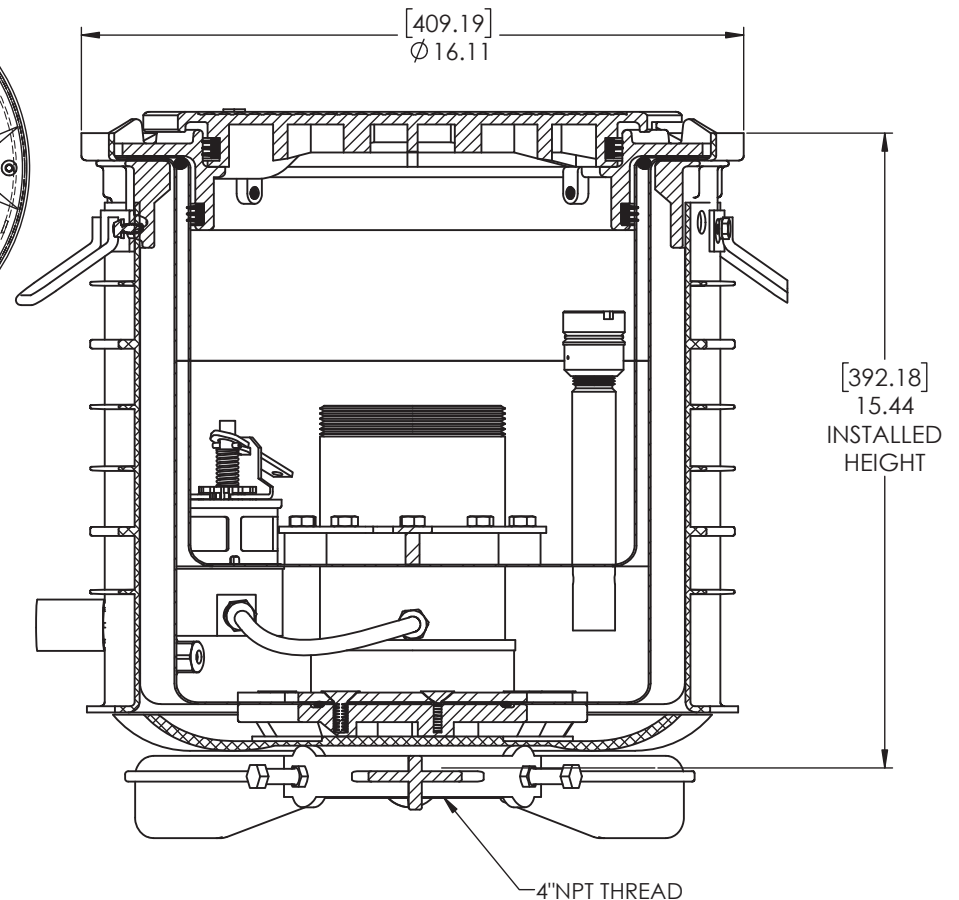
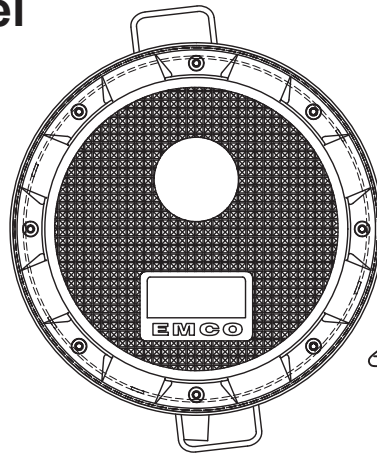

SECTION G-G  
SCALE 1 : 1.5

**EMCO**®

EMCO WHEATON RETAIL CORPORATION  
2300 INDUSTRIAL PARK DRIVE  
WILSON, N.C. 27893

DO NOT SCALE DRAWING—WORK TO DIMENSIONS SHOWN  
DIMENSIONS ARE IN INCHES (DIMENSIONS IN BRACKETS ARE IN MILLIMETERS)

UNLESS OTHERWISE SPECIFIED

DECIMALS	ANGLES
.X ± .030	.XX ± .015
.XXX ± .005	± 1°

CASTING TOLERANCES TO INDUSTRY STANDARDS  
MACHINED SURFACES 125 RMS REMOVE ALL BURRS

THE INFORMATION AND DESIGN DISCLOSED BY AND THE COPYRIGHT IN THIS DRAWING ARE THE PROPERTY OF EMCO WHEATON RETAIL CORP. AND CANNOT BE USED WITHOUT WRITTEN PERMISSION.

DRAWN BY GEB	DATE 1/21/15	USED ON N/A
CHECKED BY	DATE	PROJECT NUMBER
APPROVED BY	DATE	SCALE N/A
MATERIAL	WEIGHT	CASTING NUMBER

SYM	REVISIONS	DATE	BY
PART NAME <b>DW SST 16" CTR CONT MH +EVR DRN SENSOR READY</b>			
SIZE	DRAWING NUMBER.	REV.	
<b>D</b>	<b>A1005-518FDX-CMR</b>	<b>B</b>	