

A1005-518

Single Wall Stainless Steel Spill Containment

Specifications

- Non-eplaceable
- 5 gal capacity
- Single wall
- Weights: Lid 15.9 lbs, Total: 68.4 lbs

Materials

- Cast iron rim
- Cast iron water-resistant lid, built-in handle & exclusive triple wiper seal
- Stainless steel bucket

Application

- Grade level
- Installs 16" on center
- 4" NPT Screw-on

Approvals

- ULC Listed MH21149
- FL DEP # EQ-524
- Lid meets H20 Load Rating

Color Variant Part Numbers

Model No.	Rim/Lid	Drain	Sensor/Gage	Adapter
A1005-518	Black	No	N/A	N/A

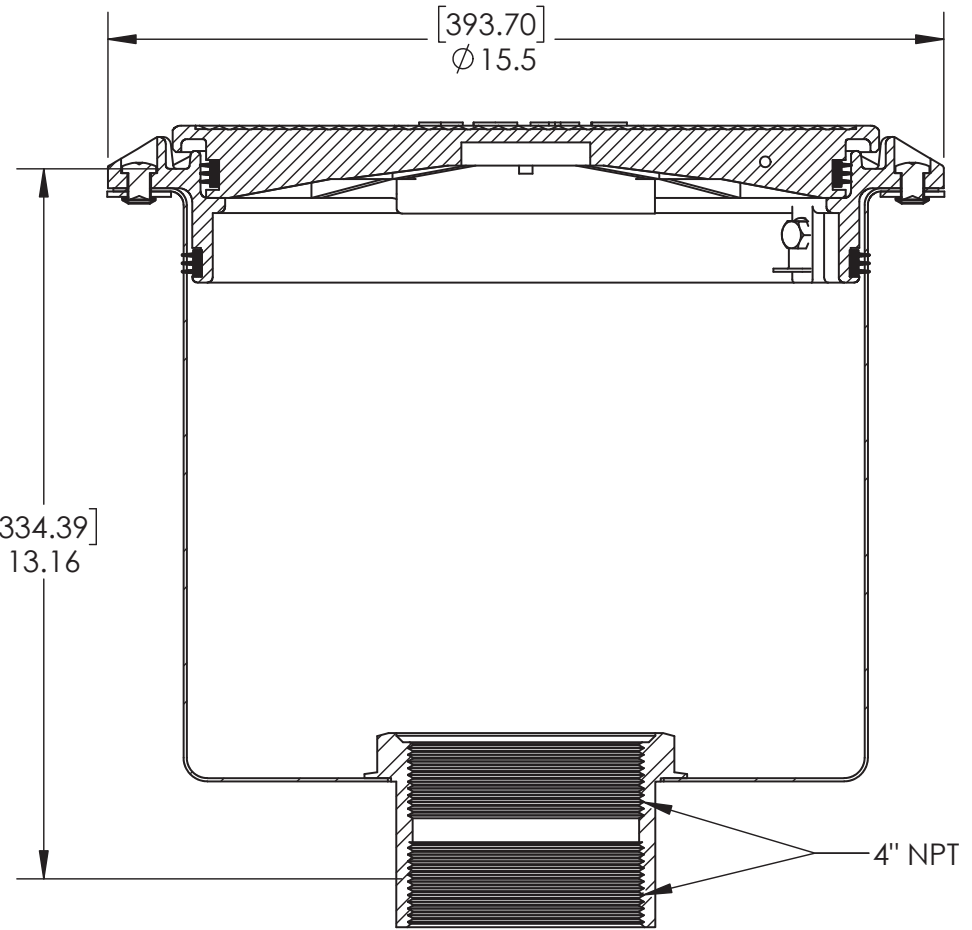
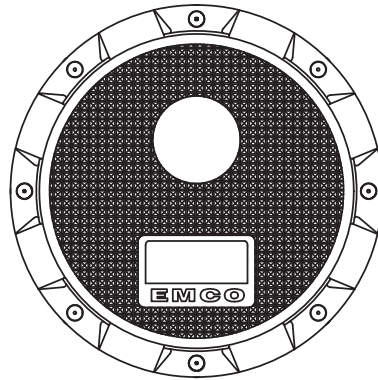

SECTION A-A
SCALE 1 : 4



EMCO WHEATON RETAIL CORP.
2300 INDUSTRIAL PARK DRIVE
WILSON, N.C. 27893
emcoretail.com

DO NOT SCALE DRAWING-WORK TO DIMENSIONS SHOWN
DIMENSIONS ARE IN INCHES (DIMENSIONS IN BRACKETS ARE IN MILLIMETERS)

UNLESS OTHERWISE SPECIFIED

DECIMALS .X ± .030 .XX ± .015 .XXX ± .005 ANGLES ± 1°

CASTING TOLERANCES TO INDUSTRY STANDARDS
MACHINED SURFACES 125 RMS REMOVE ALL BURRS

THE INFORMATION AND DESIGN DISCLOSED BY AND THE COPYRIGHT IN THIS DRAWING ARE THE PROPERTY OF EMCO WHEATON RETAIL CORP. AND CANNOT BE USED WITHOUT WRITTEN PERMISSION.

B	UPDATE	8/9/19	GEB
A	MARKETING	06/07/17	NPC
SYM	REVISIONS	DATE	BY
PART DESCRIPTION			
SW SST SPILL CONT. THREAD-ON			
SIZE	DRAWING NUMBER.	PAGE	REV.
A	A1005-518	1/1	B

DRAWN BY	DATE	USED ON	CASTING NUMBER
NPC	6/7/2017		