

**EMCO**®  
WHEATON RETAIL

Direct Burial Phase I EVR System  
Executive Order VR-105

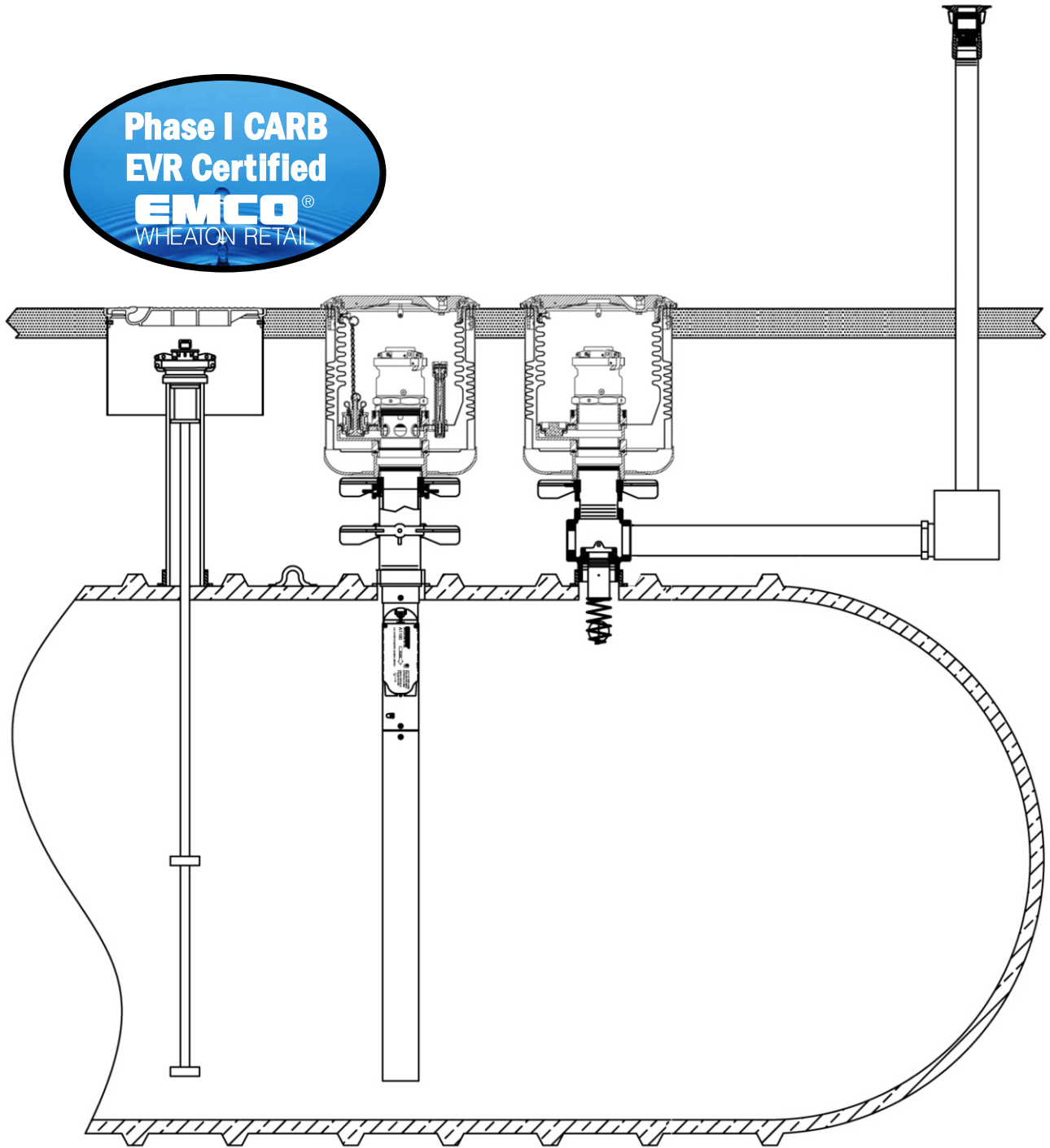

**Affordable • Watertight • Serviceable • Compliant**

# A1004EVR Direct Burial Spill Containment

## Field Replaceable

**Never  
Break Concrete  
Again!**

### Guide Specification:

- Nominal capacity of 5 or 15 US gallons
- 4-inch NPT thread connection, requires no face seal adapter
- Heavy duty, snow plow resistant, ductile iron rim and lid, exceeds DOT H-20 loading specifications
- Lid w/triple wiper seal
- Replaceable from grade level HDPE primary and secondary bellows
- Drain valve w/ filter or plug option
- EZ-Gage or float sensor option for interstitial monitoring of secondary containment
- HDPE or galvanized gravel guard
- HDPE gravel pan

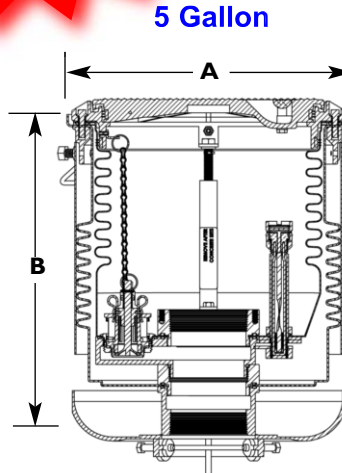

**A1004EVR-316S**

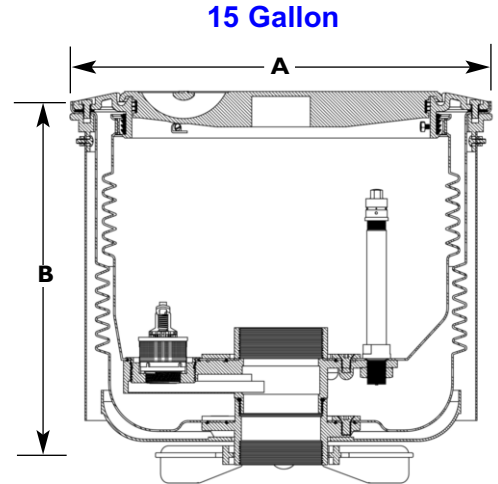

**A1004EVR-215S**

Model No.	Description	Width Dia. A	Installed Ht. B	Lid Dia.	Lid Wt.	Total Wt.	Drain Type
A1004EVR-316A	SW, 5 gal, 16" center	16.0"	15.0"	13.2"	15.9 lbs.	66.0 lbs.	Drain Valve
A1004EVR-317A	SW, 5 gal, 16" center	16.0"	15.0"	13.2"	15.9 lbs.	63.0 lbs.	None
A1004EVR-215A	SW, 15 gal	22.6"	18.0"	17.1"	29.5 lbs.	126.0 lbs.	Drain Valve
A1004EVR-316S	DW, 5 gal, 16" center	16.0"	17.1"	13.2"	15.9 lbs.	84.0 lbs.	Drain Valve
A1004EVR-317S	DW, 5 gal, 16" center	16.0"	17.1"	13.2"	15.9 lbs.	79.9 lbs.	None
A1004EVR-215S	DW, 15 gal	22.6"	19.0"	17.1"	29.5 lbs.	151.0 lbs.	Drain Valve

## Field Non-Replaceable

### Guide Specification:

- Nominal capacity of 5 US gallons
- 4-inch NPT thread connection, requires no face seal adapter
- Heavy duty, snow plow resistant, ductile iron rim and lid, exceeds DOT H-20 loading specifications
- Lid w/triple wiper seal
- Non-replaceable from grade level HDPE primary bellows
- Drain valve w/filter or plug option
- HDPE gravel guard
- HDPE gravel pan

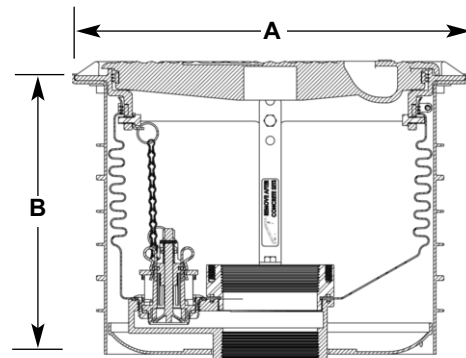

Model No.	Description	Width Dia. A	Installed Ht. B	Lid Dia.	Lid Wt.	Total Wt.	Drain Type
A1004EVR-010	Slimline, SW, 5 gal	17.6"	13.6"	15.3"	20.0 lbs.	58.5 lbs.	Drain Valve
A1004EVR-011	Slimline, SW, 5 gal	17.6"	13.6"	15.3"	20.0 lbs.	57.9 lbs.	None



# A1100EVR Overfill Prevention Valve

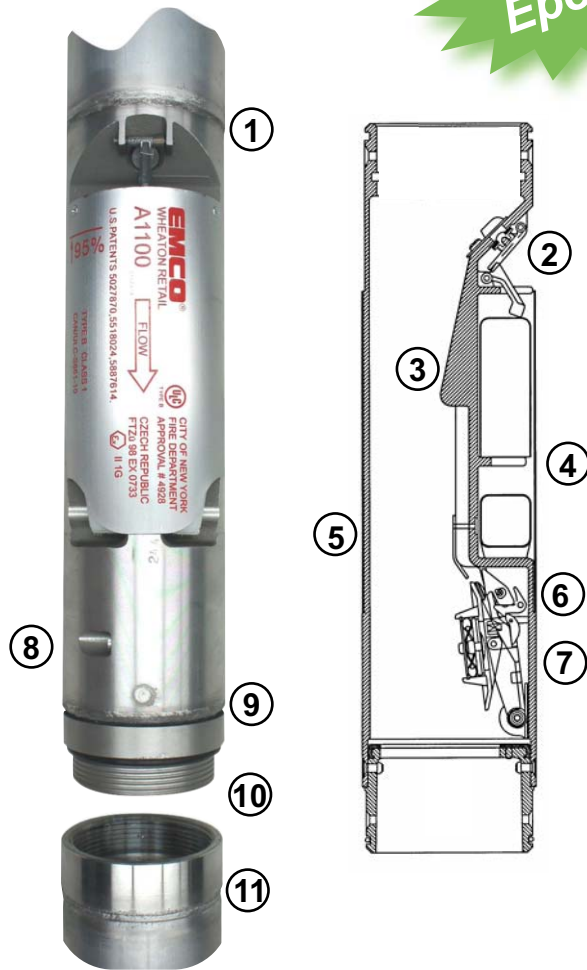

**Guide Specification:**

- 1 Upper drop tube to valve body factory welded
  - 2 Bleed valve drains fuel delivery hose after 95% shut-off
  - 3 Diverter fins protect flapper valve during routine "tank stick" gauging
  - 4 Top and bottom floats contained in protective sleeve to insure damage-free installation and removal from tank fill riser
  - 5 Die cast aluminum valve body design provides the highest delivery flow rate
  - 6 Spring loaded reset function opens flapper valve and allows for immediate "tank stick" gauging
  - 7 Flapper valve provides positive fuel shut-off at 95% total storage tank capacity
  - 8 External field test port allows for manual routine testing of flapper valve
  - 9 Lower drop tube to valve body factory welded
  - 10 Valve body to male coupling factory welded
  - 11 Female coupling to lower drop tube factory welded
- Materials and seals are compatible with up to E25 ethanol blend gasoline and B20 biodiesel blends
  - Factory tested for operability and vapor tightness integrity
  - The A1100EVR OPV is not recommended for underground storage tanks under 6.5 ft in diameter

Model No.	Overall Length	Max. Riser Length	Nominal Tank Dia.	Weight
A1100EVR-055	14.0 ft.	4.6 ft.	8 ft.	22 lbs.
A1100EVR-056	16.0 ft.	5.5 ft.	10 ft.	24 lbs.
A1100EVR-057	18.2 ft.	6.2 ft.	12 ft.	27 lbs.
A1100EVR-058	21.7 ft.	9.5 ft.	12 ft.	30 lbs.



**A0020EVR**  
Rolled Edge Collar



**A0020EVR**  
Heavy Duty Collar

# A0020EVR Straight Drop Tube

**Guide Specification:**

- 4-inch diameter aluminum construction
- Available standard rolled edge or heavy duty collar
- Installs on a typical 4-inch tank fill riser for below ground storage tanks

Model No.	Model No.	Overall Length
<b><u>Rolled Edge Collar</u></b>	<b><u>Heavy Duty Collar</u></b>	
A0020EVR-004	A0020EVR-004	12'
A0020EVR-005	A0020EVR-005	15'
A0020EVR-007	A0020EVR-007	17'
A0020EVR-008	A0020EVR-008	14'

# Phase I EVR Components



**A0097-005**  
Fill Adapter Cap



**A0099-002**  
Vapor Adapter Cap



**A0097-010**  
ATG Probe  
Adapter Cap

**Guide Specification:**

- Top-seal cam and groove design for vapor tightness integrity
- Aluminum body powder coated orange or gray for field identification
- Lockable toggle action aluminum handle with self-aligning cams
- The Model A0099-003 includes a 12-inch chain to prevent theft
- The Model A0097-010 includes cord grip for use with ATG probes
- A0097-010A includes ATG probe cap and adapter

**Guide Specification:**

- A 360 degree rotation prevents accidental loosening from 4-inch tank fill or vapor riser
- Brass construction cam and groove design for use with top-seal caps for vapor tightness integrity
- Flat gasket with 4-inch NPSM thread connection
- The Model A0076-124S available with a normally closed poppet
- The Model A0030-014 is non-swivel for use with ATG probes
- Allows for complete field serviceability should the swivel adapter fail CARB static torque TP-201.B, leak tightness integrity tests TP-201.D or TP-201.3



**A0030-124S**  
Swivel Fill Adapter



**A0076-124S**  
Swivel Vapor Adapter



**A0030-014**  
ATG Probe Adapter

**Guide Specification:**

- Lowers the top of the drop tube collar below the spill containment drain valve path
- Two-piece stainless steel construction



**494096 Riser Seal**

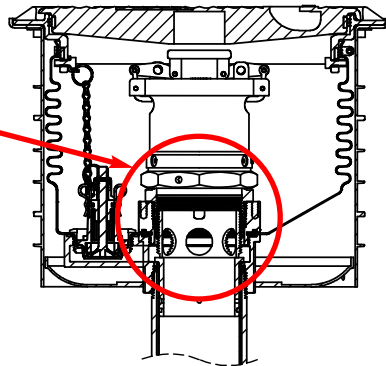

**A0075**  
Ball Float



**A0079 Extractor**  
Cross Fitting



**A0079 Extractor**  
Tee Fitting



**A0179**  
Extractor Cage



**A0279 Extractor**  
Test Plug