

EMCO

WHEATON RETAIL

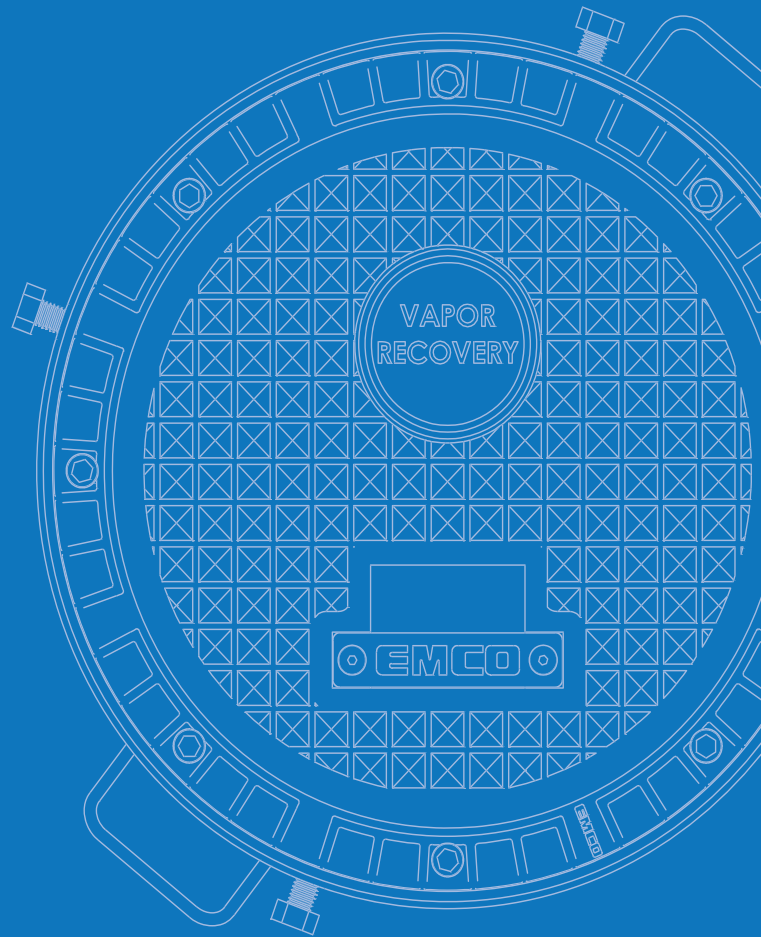
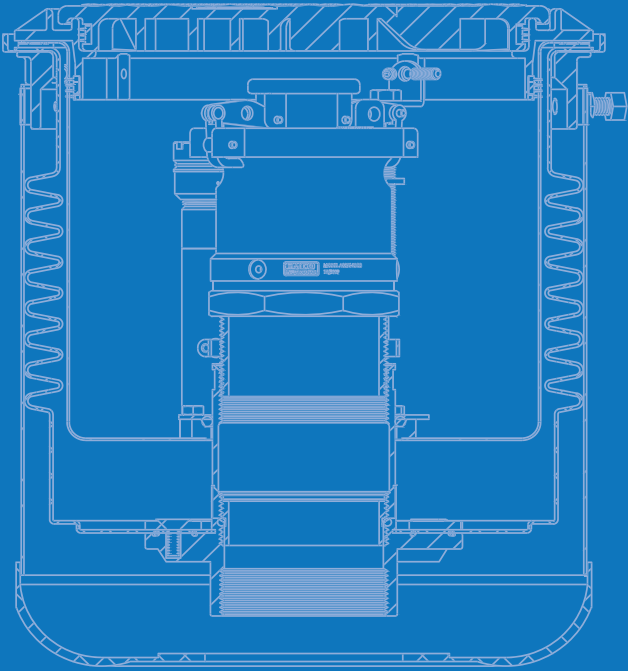

ENGINEERING CUSTOMER SATISFACTION™

Underground Storage Tank Equipment

A0030/A0089 Fill Adapters	6
A0097 Fill Caps	7
A0076 Vapor Adapters	8
A0099 Vapor Caps	9
A0031 Adapter Accessories	10
A0097 ATG Caps/Adapters	11
A0060 Emergency Shear Valves	12-13
A0063 Vapor Shear Valve	14
A1100 Overfill Prevention Valves/Assemblies	16-23
A0020 Drop Tubes	24
A0070/A0088 Coaxial Drop Tubes	25
A0079 Extractor Fittings	26-27
A0075/A0078 Ball Floats	28
A0066 Check Valve	29
A0750 Ball Valve	29
A0732 Underpump Union Check Valve	29
A0084 Pressure Vacuum Vents	30
A4103/A0785 Tank Vents	31
A0996 ID Tags	32-33
A0997 Tank ID Tags	32-33
A0998 In-ground ID Markers	32-33
Z0838/Z0839 Sealants	34

Spill Containment

Selection Chart	36-37
Replaceable/Non-Replaceable	
A1004EVR Stainless Primary/Poly Secondary	38-39
A1005 Stainless Steel	40
A1005 DEF	41
A1005 Stainless Steel 15gal	42
A1005 Below Grade	42
A1005 Stainless Steel, Non-replaceable	43
A1004EVR Poly	44-45
A1005 Remote Fill	46-47
A1005 Remote Fill Vaults	48-49
A1004EVR Multi-Port	50
A1008 Multi-Port	51
Retrofit	52-58
Emco	53
Fairfield	54
Pemco	54
Franklin Fueling	54
OPW	55
OPW 500/700 Series Retrofit	56
Universal	57
Pomeco	57
Accessories/Replacement Parts/Testing Equip.	58
Riser Extensions and Pipe Nipples	
A0031 Riser Extensions	59
A7901 Pipe Nipples	60
Replacement Parts	
A1004/A1005 Replacement Kits and Parts	61-63
A1004/A1005 Replacement Lids	64-67
Spill Containment Accessories	
A0028 Riser Lock	68
A0333 Hand Pump	68

Tools & Test Equipment

A0081 Tools	70-71
Tools, Miscellaneous	72
Test Equipment	73

Manholes

A0716 Composite Manholes	76-79
A0717 Standard Round Manholes	80-81
A0717 Square Manholes and Vaults	82-83
A0717 Round Vaults	82-83
A0721 Monitoring Well Manholes	84-85
A0727 Well Protectors	86

Phase I EVR

Caps and Adapters	89
A1004EVR Direct Bury Spill Containment	90-91
A1004EVR Multi-Port Spill Containment	92
A1100EVR Overfill Prevention	93
A0020EVR Drop Tubes	94
Installation and Maintenance Tools	94

Phase II EVR

A4005EVR Balance Vapor Recovery Nozzle	99
A4119EVR Coaxial SafeBreak®	101
Repair and Replacement Kits/Service Tools	102

Nozzles

A4005 Balance Vapor Recovery	105
A4005/A4015 Replacement Parts	106
A0500 Splash Guards	107

Dispenser Accessories

A2119/A3019 Standard Shear Pin SafeBreaks®	110
A2219/A3219 Standard Reconnectable SafeBreaks®	110
A4119EVR Coaxial SafeBreak®	111
A4110EVR Coaxial Hose Swivel	111
A0360 Hose Swivels	112
A4043/A4041 Coaxial Splitters	112
A0010 Flow Regulators	113
563639 Adapters	113
A0729 E-Stop Switch Pedestal	114

Competitor Cross Reference 116-120

Numerical Index 122-124

Warranty Policy 126

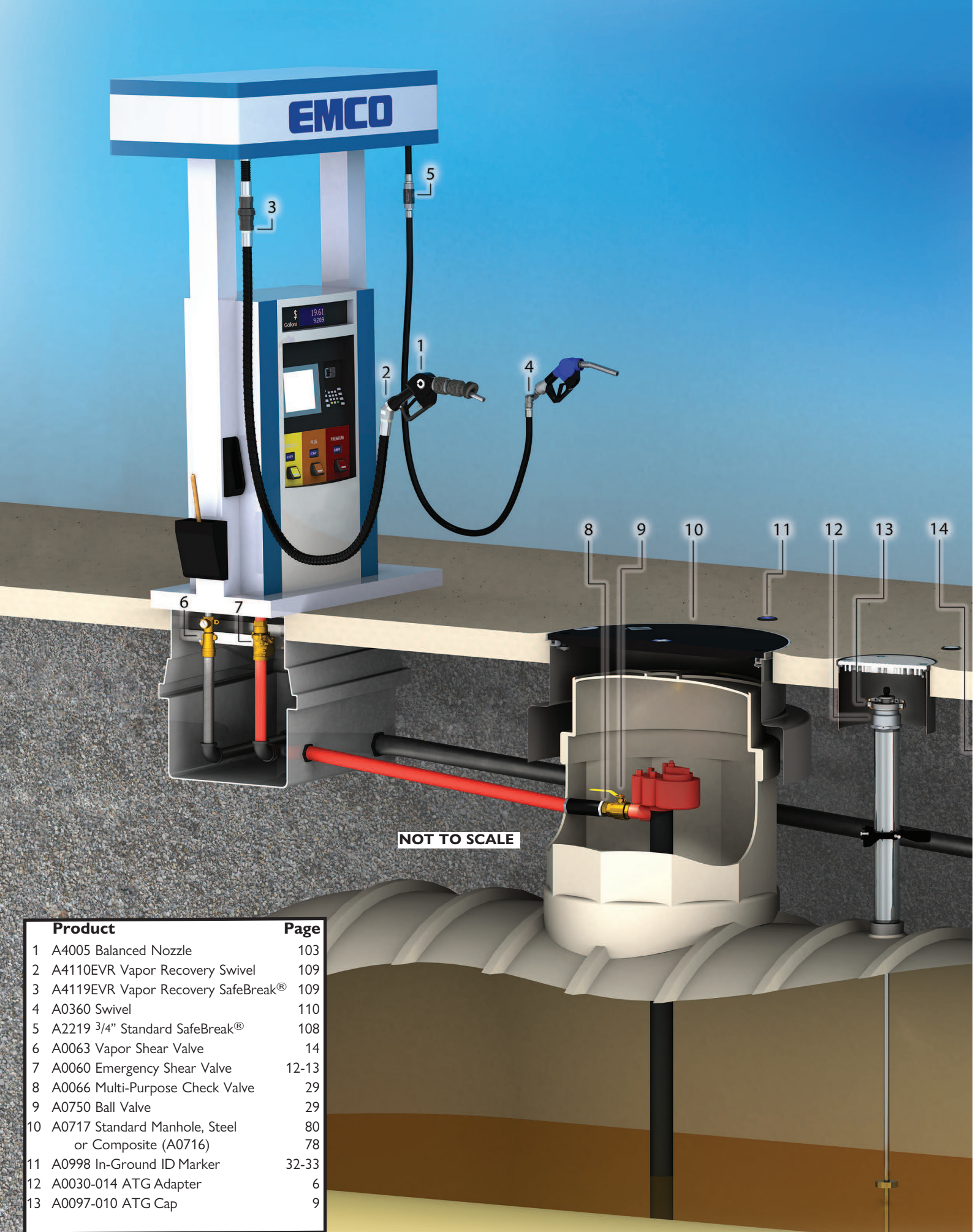

Product	Page
1 A4005 Balanced Nozzle	103
2 A4110EVR Vapor Recovery Swivel	109
3 A4119EVR Vapor Recovery SafeBreak®	109
4 A0360 Swivel	110
5 A2219 3/4" Standard SafeBreak®	108
6 A0063 Vapor Shear Valve	14
7 A0060 Emergency Shear Valve	12-13
8 A0066 Multi-Purpose Check Valve	29
9 A0750 Ball Valve	29
10 A0717 Standard Manhole, Steel or Composite (A0716)	80 78
11 A0998 In-Ground ID Marker	32-33
12 A0030-014 ATG Adapter	6
13 A0097-010 ATG Cap	9

EMCO® WHEATON RETAIL

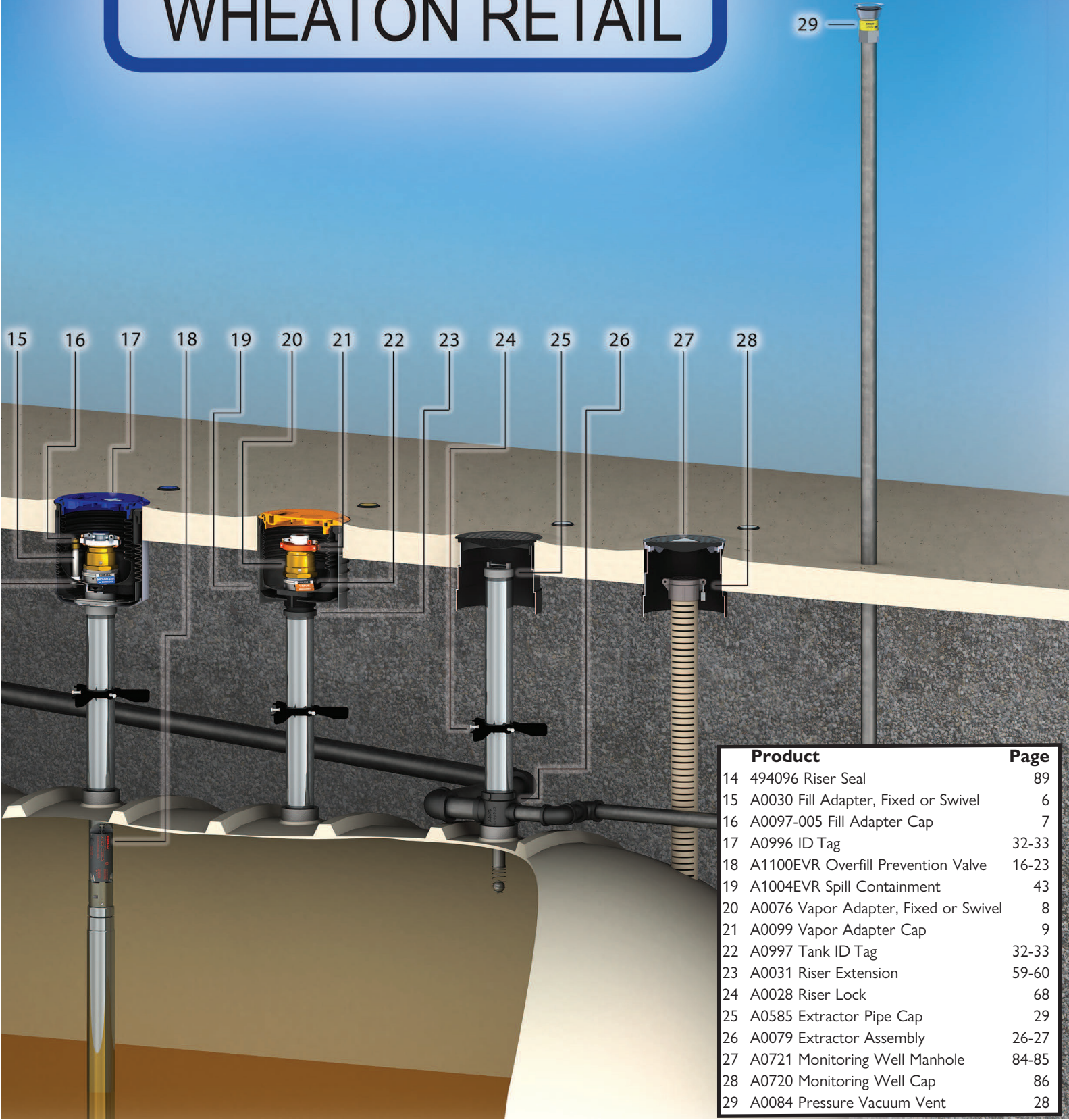

	Product	Page
14	494096 Riser Seal	89
15	A0030 Fill Adapter, Fixed or Swivel	6
16	A0097-005 Fill Adapter Cap	7
17	A0996 ID Tag	32-33
18	A1100EVR Overfill Prevention Valve	16-23
19	A1004EVR Spill Containment	43
20	A0076 Vapor Adapter, Fixed or Swivel	8
21	A0099 Vapor Adapter Cap	9
22	A0997 Tank ID Tag	32-33
23	A0031 Riser Extension	59-60
24	A0028 Riser Lock	68
25	A0585 Extractor Pipe Cap	29
26	A0079 Extractor Assembly	26-27
27	A0721 Monitoring Well Manhole	84-85
28	A0720 Monitoring Well Cap	86
29	A0084 Pressure Vacuum Vent	28

Fill Adapters

A0030-124S Fill Swivel Adapter

The Emco Wheaton A0030-124S Swivel Fill Adapter typically installs on the tank fill riser. The top of the adapter rotates 360 degrees while the base is stationary, preventing accidental loosening from the riser during fuel deliveries. The A0030-124S is **field serviceable** using the kits below. Use with the A0097 Fill Cap. Use the Emco Wheaton A0081-001 Adapter Wrench for installation and removal.



A0030-124S



Model No.	Material	Thread Size	Cam & Groove	Lbs.
*A0030-124S	Brass	4" Female NPSM	4"	7.1
**A0030-124SS	Stainless Steel	4" Female NPSM	4"	7.1

*Phase 1 EVR E.O. VR-105

**For use with E85, DEF & ULSD

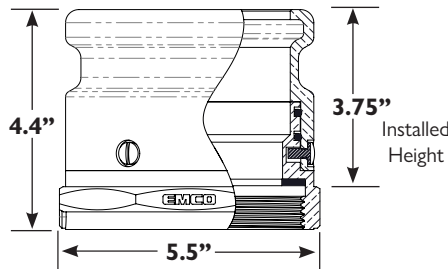

Materials:

Body: Brass
O-rings: Viton®
Gasket: Buna-N

Viton® is a registered trademark of The Chemours Company

Approvals:

Complies with EPA 40 CFR Part 63
UL 2583 Listed MH46838
CARB Executive Order VR-105

Replacement Parts:

569924 Gasket Replacement
494301 O-ring Replacement

A0030 Fill Adapter

The Emco Wheaton A0030 Adapter is designed for use with conventional dual point fill systems. Features recessed threads for easy installation and positive seating on riser pipes. Use with the A0097 Fill Cap. Notched variants are for use with the A0032-001 Adapter Clamp and comply with EPA 40 CFR Part 63 requirements.



A0030-024A



Model No.	Material	Thread Size	Lugs	Notches	Cam & Groove	Lbs.	A	B	C
A0030-014	Aluminum	4" Female NPSM	No	No	4"	1.8	5.5"	4.0"	2.0"
A0030-024	Brass	4" Female NPSM	Yes	No	4"	2.6	4.9"	2.5"	1.7"
*A0030-024A	Aluminum	4" Female NPSM	Yes	Yes	4"	1.0	4.9"	2.5"	1.7"
**A0030-024ATG	Aluminum	4" Female NPSM	No	Yes	4"	1.0	4.9"	2.5"	1.7"
A0030-024BA	Aluminum	4" Female BSPP	Yes	Yes	4"	1.0	4.9"	2.5"	1.7"
A0030-024N	Brass	4" Female NPSM	Yes	Yes	4"	2.6	4.9"	2.5"	1.7"

*Most common variant

**For Automatic Tank Gage

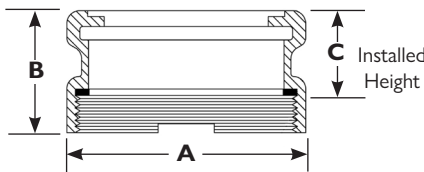

Material

Body: Aluminum or Brass
Gasket: Buna-N

Approvals:

CARB Executive Order VR-105
ULC Listed MH27242

Replacement Parts:

409628 Gasket Replacement

A0089, A0096 Coaxial Fill Adapters

Emco Wheaton Coaxial Vapor Recovery Adapters are designed for standard coaxial fill systems and coaxial systems with self-sealing vapor lines. Features recessed threads for easy installation and positive seating on riser pipes. Use Emco Wheaton A0081 Adapter Wrench for installation. The A0089 and A0096 are notched for use with the A0032-001 Adapter Clamp to comply with EPA 40 CFR Part 63 requirements.

Model No.	Use With	Size	A	Lbs.
A0089-001	Coaxial Self Sealing : A1100-08X, A0088	4" Female NPSM	3.0"	1.6
A0089-001E	Coaxial Self Sealing , E85: A1100-08X, A0088	4" Female NPSM	3.0"	1.6
A0096-001	Coaxial: A1100-06X, A0070	4" Female NPSM	2.5"	1.8

Material

Body: Aluminum

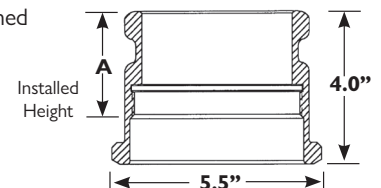

Fill Caps

A0097 Fill Cap

The Emco Wheaton A0097-005 Top Seal Fill Cap is designed for use on conventional A0030 or coaxial A0089 and A0096 Adapters. The cap is lockable and features a self-aligning, toggle-action design with center collar to prevent breakage; made of corrosion resistant aluminum and powdercoated gray for fill line identification.

Material

Body: Aluminum
 Cams: Brass
 Links: Steel
 Seal: Buna-N

Approvals:

CARB E.O. G-70-97-A
 CARB Executive Order VR-105
 Complies with EPA 40 CFR Part 63
 UL 2583 Listed MH46838

Replacement Parts:

570739 Replacement Gasket

Model No.	Cam & Groove	Lbs.
A0097-005	4"	1.6

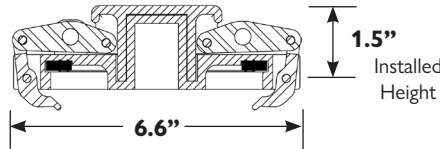

A0097-005



A0097-004LP Low Profile Fill Cap

The A0097-004LP Low Profile Fill Cap is designed for use when there is limited space between the top of the adapter and the spill containment lid. The cap is powdercoated gray for fill line identification. Robust stainless steel rivets are installed into a counterbore in the handle eliminating an avenue for unauthorized access.

Material

Body: Aluminum
 Lever: Ductile Iron
 Gasket: Buna-N

Approvals:

CARB Executive Order VR-105

Replacement Parts:

570739 Replacement Gasket

Model No.	Cam & Groove	Lbs.
A0097-004LP	4"	3.5

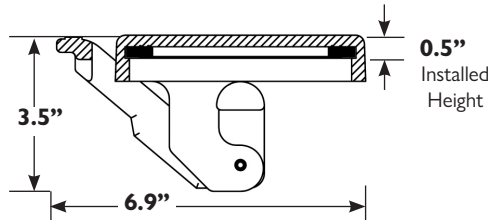

A0097-004LP

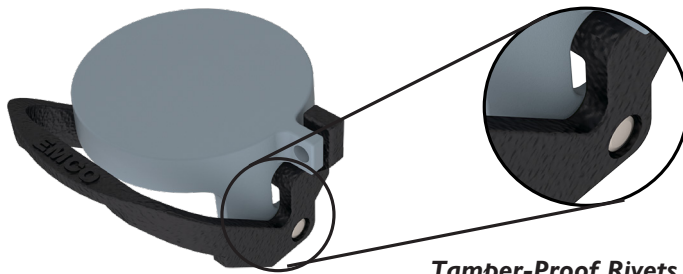

Vapor Adapters

A0076-124S Vapor Swivel Adapter

The Emco Wheaton A0076-124S Vapor Swivel Adapter typically installs on the tank vapor riser. The top of the adapter rotates 360 degrees while the base is stationary, preventing accidental loosening from the riser during fuel deliveries. A normally closed poppet valve opens to recover the vapor. The A0076-124S is **field serviceable** using the kits below. Use with the A0099-002 Vapor Cap. Use the Emco Wheaton A0081-001 Adapter Wrench for installation and removal.



A0076-124S



Model No.	Material	Thread Size	Cam & Groove	Lbs.
A0076-124S	Brass	4" Female NPSM	4"	6.4
** A0076-124SS	Stainless Steel	4" Female NPSM	4"	6.4

**For use with E85, DEF, & ULSD

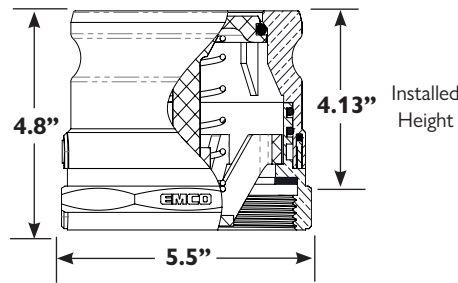

Material
 Body: Brass
 O-rings: Viton®
 Gasket: Buna-N

Viton® is a registered trademark of The Chemours Company

Approvals:
 Complies with EPA 40 CFR Part 63
 CARB Executive Order VR-105
 ULC Listed MH27242

Replacement Parts:
 569924 Gasket Replacement
 494301 O-ring Replacement

A0076 Vapor Adapter

The Emco Wheaton A0076 Vapor Adapter is used in dual point fill systems on the vapor return line. It features a poppet design which seals off the vapor path and external lugs on the adapter body for easy installation. Use with the A0099-002 Vapor Cap.



A0076-005

Model No.	Thread Size	Cam & Groove	Lbs.	A	B	C
A0076-002	3" Female NPSM	4"	2.9	4.0"	5.6"	5.0"
*A0076-005	4" Female NPSM	4"	3.1	4.9"	5.0"	4.2"
A0076-009	3" Female BSPP	4"	2.1	4.0"	5.6"	5.0"

*Most common variant

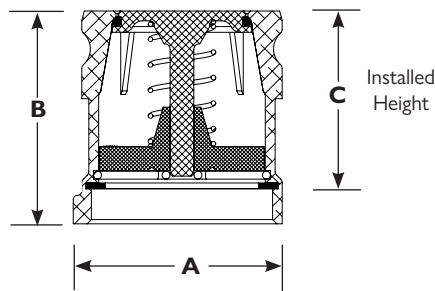

Material:
 Body: Aluminum
 O-rings: Viton®
 Gasket: Buna-N

Approvals:
 CARB Executive Order G-70-97-A
 ULC Listed MH27242

Replacement Parts:
 569924 Gasket replacement

Vapor Caps

A0099 Vapor Adapter Cap

The Emco Wheaton A0099-002/003 Vapor Adapter Cap features a cam system designed for Stage I vapor recovery dual point systems. The cap is lockable and features a self-aligning, toggle-action design with center collar to prevent breakage. The A0099 is made of corrosion resistant aluminum, powdered coated orange for vapor line identification.

Material

Body: Aluminum
 Cams: Brass
 Links: Stainless Steel
 Seal: Buna-N

Approvals:

CARB E.O. G-70-97-A
 CARB Executive Order VR-105
 Complies with EPA 40 CFR Part 63

Replacement Parts:

570739 Replacement Gasket

Model No.	Cam & Groove	Lbs.
A0099-002	4"	1.4
A0099-003	4" w/chain	1.8

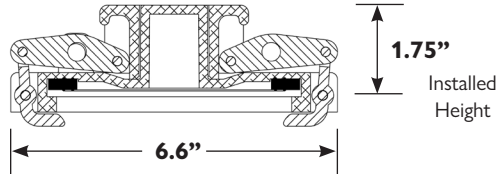

A0099-002



A0099-001TEST Vapor Test Cap

The A0099-001TEST Vapor Test Cap is used when performing a pressure decay test. The cap incorporates the same features as the A0099-002 Vapor Cap. The extended tube underneath the cap opens the poppet on the vapor adapter. Pressure is injected through the Schrader valve, and a gauge can be connected to the barbed fitting.

Material

Body: Aluminum
 Cams: Brass
 Links: Stainless Steel
 Seal: Buna-N

Replacement Parts:

570739 Replacement Gasket

Model No.	Cam & Groove	Lbs.
A0099-001TEST	4"	1.4



A0099-001TEST

A0099-004LP Low Profile Vapor Adapter Cap

The A0099-004LP Low Profile Cap is designed for use when there is limited space between the top of the adapter and the spill containment lid. The cap is powdercoated orange for vapor line identification.

Material

Body: Aluminum
 Lever: Ductile Iron
 Gasket: Buna-N

Approvals:

CARB Executive Order VR-105

Replacement Parts:

570739 Replacement Gasket

Model No.	Cam & Groove	Lbs.
A0099-004LP	4"	3.5

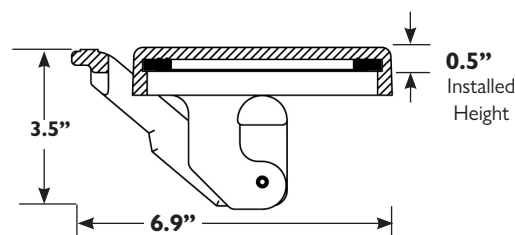

A0099-004LP



Adapter Accessories

A0030 Tank Probe Adapter

The Emco Wheaton A0030-014F Tank Probe Adapter is designed for use with the Franklin Fueling INCON Tank Probe. Includes the aluminum body, aluminum support washer and two rubber gaskets. INCON support plate not included.

Model No.	Material	Thread Size	Lugs	Cam & Groove	Lbs.	Outside Dia.	Overall Ht.	Install Ht.
A0030-014F	Aluminum	4" Female NPSM	No	4"	1.9	5.5"	4.0"	2.0"

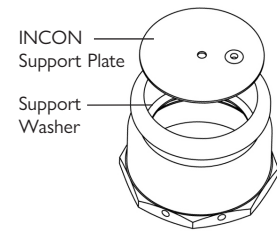

A0030-014F

A0031 Riser Adapter Extension

Raise your adapter 2" closer to grade. This **stainless steel** adapter extension installs in your container with a 4" NPSM female thread sealed by a Nitrile flat gasket. The top 4" NPSM male threads accept a product/vapor adapter. The Emco Wheaton A0031-200S Stainless Steel Adapter Extension is designed for use with top or remote fill Phase I EVR system applications.



A0031-200S

Model No.	Installed Height	Top Threads	Bottom Threads	Lbs.
A0031-200S	2.00"	4" NPSM	4" NPSM	1.7

A0031-200S
2" Extension

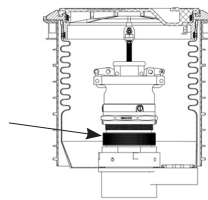

Material:
Body: Stainless Steel

Approvals:
CARB Executive Order VR-105



A0032 Adapter Clamp

The Emco Wheaton A0032-001 Adapter Clamp installs on the riser pipe or pipe nipple. The A0032 is used with the following non-swivel adapters: A0089, A0096, A0030-024A, A0030-024BA, A0030-024N, & A0076-005. The tabs are aligned with the notches on the adapter, and the three set screws are tightened to prevent the adapter from loosening in use, in compliance with EPA 40 CFR Part 63 requirements.



A0032-001

Installed on pipe nipple with
A0030-024 Adapter

Model No.	Material	Size	Lbs.
A0032-001	Steel	4"	0.7



Material:
Body: Steel

A0033EVR Debris Collector

The Emco Wheaton A0033EVR-004 Debris Collector attaches to the bottom of any fill adapter to prevent large debris from entering the underground storage tank. There are no restrictions during a fuel drop, and the center hole allows for fuel sampling.



A0033EVR-004

Installed in A0030-124S Swivel Fill Adapter

Model No.	Material	Lbs.
A0033EVR-004	Stainless Steel	0.25

Material:
Body: Stainless Steel
Gasket: Nitrile

Approvals:
CARB Executive Order VR-105



Tank Gauge Caps

A0097-010 Tank Gauge Cap

The A0097-010 Tank Gauge Cap has the same features of the A0097-005 Fill Cap and is designed with a grommet to allow a cable to pass through the cap. The A0097-010 comes with two sizes of leak tight connector nut fittings: .125"-.375" and .190"-.250".

Material

Body: Aluminum
 Cams: Brass
 Links: Steel
 Seal: Buna-N

Approvals:

CARB Executive Order VR-105

Replacement Parts:

570739 Replacement Gasket

Model No.	Description	Lbs.
A0097-010	4" Cap w/ Grommets	1.7
A0097-010A	4" Cap w/ Grommets & Adapter	3.4

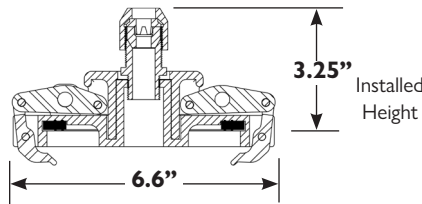

A0097-010



A0097-010A

Includes A0097-010 Tank Gauge Cap and A0030 Adapter with no lugs for pass-through ATG float

A0097-010LP Low Profile Tank Gauge Cap

The A0097-010LP Tank Gauge Cap has the same features of the A0097-004LP Fill Cap and is designed with a grommet to allow a cable to pass through the cap. The A0097-010LP comes with two sizes of leak tight connector nut fittings: .125"-.375" and .190"-.250".

Material

Body: Aluminum
 Lever: Ductile Iron
 Gasket: Buna-N

Replacement Parts:

570739 Replacement Gasket

Model No.	Description	Lbs.
A0097-010LP	4" Cap w/ Grommets	3.6
A0097-010ALP	4" Cap w/ Grommets & Adapter	5.3

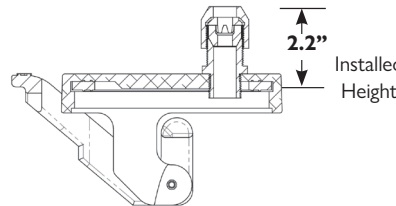

A0097-010LP

A0097-010ALP

Includes A0097-010LP Tank Gauge Cap and A0030 Adapter with no lugs for pass-through ATG float

A0585-003A One Piece Tank Gauge Cap

The A0585-003A Tank Gauge Cap offers a one piece solution and the lowest installed height of any Emco ATG cap. The 4" NPSM female threaded cap requires no installation of a product adapter, removing a potential leak point. This cap accommodates wire diameters between 1/8" to 3/8" and includes a 3/4" hex for proper torque tightening.

Replacement Parts:

569924 Gasket Seal, Nitrile

Approvals:

CARB Executive Order VR-105

Model No.	Description	Lbs.
A0585-003A	One Piece Cap w/ Grommets	1.01

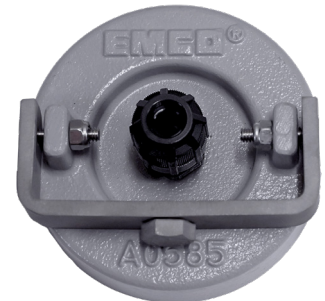
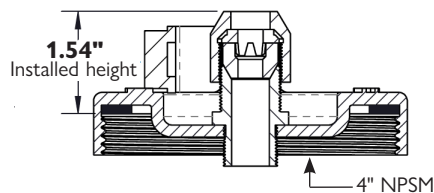

Emergency Shear Valves

A0060 Underpump Emergency Valve

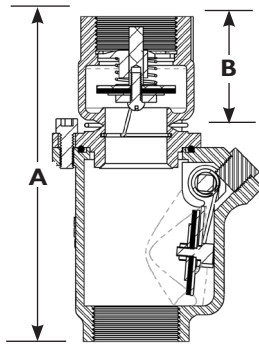

Stainless Steel

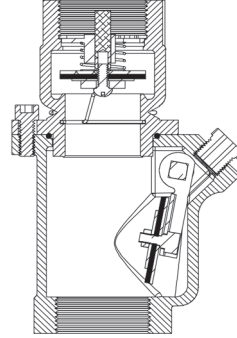
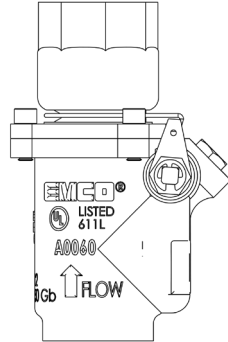

Cast Iron



Available with Stainless Steel Body and Top for E85, DEF, ULSD, & Biodiesel Blends up to B100

The Emco Wheaton A0060 Emergency Shear Valve incorporates a replaceable shear section and a heat sensitive fusible link assembly. The valve can be manually operated to facilitate dispenser maintenance and incorporates a 3/8" test port. The closing poppet assembly is positioned out of the fuel flow path to minimize pressure drop. The A0060 utilizes a standard three boss mounting arrangement. Available in single or double poppet variants. Cast iron versions are powder coated Black.

- UL Listed MH6518
- ATEX FTZU 14 ATEX 0204

Material
 Body: Cast Iron or Stainless Steel
 Spring: Stainless Steel
 Seal: Viton®

Viton® is a registered trademark of The Chemours Company

Model No. Cast Iron	Model No. Stainless Steel	Description	Inlet	Outlet	Cast Iron Lbs.	SST Lbs.	A	B
A0060-002	A0060-002S	1 1/2" Single Poppet	Female	Male	5.7	6.4	6.9"	2.2"
* A0060-003	A0060-003S	1 1/2" Single Poppet	Female	Female	5.6	6.3	6.7"	1.7"
A0060-015	A0060-015S	1 1/2" Single Poppet	Female BSPT	Male BSPT	5.7	6.4	7.9"	3.2"
A0060-016	A0060-016S	1 1/2" Single Poppet	Female BSPT	Female BSPT	5.6	6.3	6.9"	2.2"
A0060-022	A0060-022S	1 1/2" Double Poppet	Female	Male	5.8	6.7	7.9"	3.2"
* A0060-023	A0060-023S	1 1/2" Double Poppet	Female	Female	5.7	6.4	6.9"	2.2"
A0060-025	A0060-025S	1 1/2" Double Poppet	Female BSPT	Male BSPT	5.8	6.7	7.9"	3.2"
A0060-026	A0060-026S	1 1/2" Double Poppet	Female BSPT	Female BSPT	5.7	6.4	6.9"	2.2"

*Most common variant

Replacement Parts

Part No. Cast Iron	For Use On	Part No. Stainless Steel	For Use On	Description	Outlet	Cast Iron Lbs.	SST Lbs.
492938	A0060-002	492938S	A0060-002S	1 1/2" Replacement Top; 1 Poppet	Male	2.2	2.5
492939	A0060-003	492939S	A0060-003S	1 1/2" Replacement Top; 1 Poppet	Female	2.3	2.6
493885	A0060-016	493885S	A0060-016S	1 1/2" Replacement Top; 1 Poppet	Female BSPT	1.4	1.6
493886	A0060-015	493886S	A0060-015S	1 1/2" Replacement Top; 1 Poppet	Male BSPT	1.6	1.8
493887	A0060-022	493887S	A0060-022S	1 1/2" Replacement Top; 2 Poppets	Male	2.7	3.0
493888	A0060-023	493888S	A0060-023S	1 1/2" Replacement Top; 2 Poppets	Female	2.7	3.0
493889	A0060-025	493889S	A0060-025S	1 1/2" Replacement Top; 2 Poppets	Male BSPT	1.6	1.8
493890	A0060-026	493890S	A0060-026S	1 1/2" Replacement Top; 2 Poppets	Female BSPT	1.6	1.8
492963K				Fusible Link Kit		0.2	
564036				Control Arm			
A0065-001				A0060 Stabilizer Bar Mounting Kit		3.8	

Emergency Shear Valves

A0060 2" Stainless Steel Emergency Valve

Material

Body: Stainless Steel
Spring: Stainless Steel
Seal: Nitrile

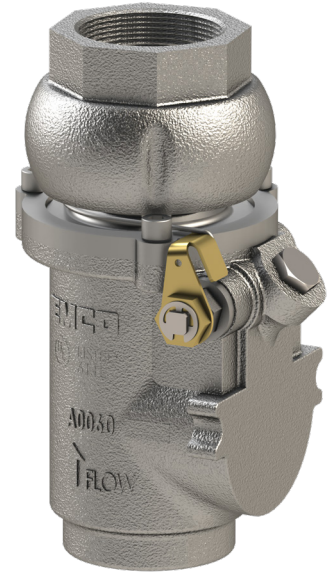
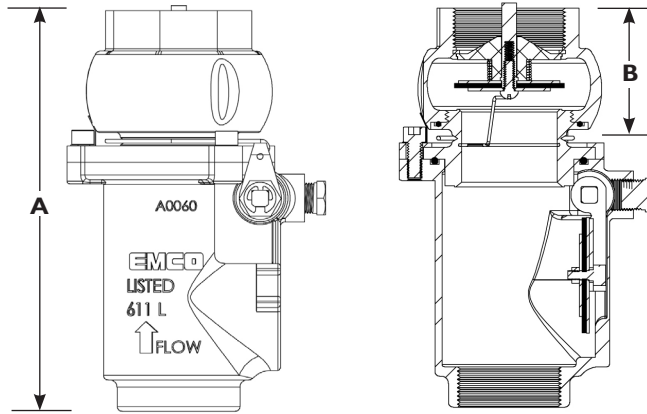

The Emco Wheaton A0060 2" Emergency Shear Valve incorporates a stainless steel design, compatible with all gasoline/alcohol blends up to E15, Ultra Low Sulfur Diesel and biodiesel blends up to B100. It is designed for installation under gasoline or diesel dispensing units. The valve incorporates a replaceable shear section and a heat sensitive fusible link assembly. The A0060 can be manually operated to facilitate dispenser maintenance and incorporates a 3/8" test port. The closing poppet assembly is positioned out of the fuel flow path to minimize pressure drop. The valve utilizes a standard three boss mounting arrangement; mounting bolts included. Single and double poppet variants available.

Model No.	Description	Inlet	Outlet	Lbs.	A	B
A0060-202S	2" Single Poppet NPT	Female	Male	7.5	9.7"	4.0"
A0060-203S	2" Single Poppet NPT	Female	Female	7.1	8.4"	2.7"
A0060-222S	2" Double Poppet NPT	Female	Male	7.7	9.7"	4.0"
A0060-223S	2" Double Poppet NPT	Female	Female	7.5	8.4"	2.7"
A0060-225S	2" Double Poppet BSPT	Female	Male	7.7	9.7"	4.0"
A0060-226S	2" Double Poppet BSPT	Female	Female	7.5	8.4"	2.7"

Replacement Parts

Part No.	Description	Outlet	Lbs.
495651S	2" Replacement Top; 1 Poppet NPT	Male	3.1
495650S	2" Replacement Top; 1 Poppet NPT	Female	2.7
495649S	2" Replacement Top; 2 Poppet NPT	Male	3.3
495657S	2" Replacement Top; 2 Poppet NPT	Female	2.9
495670S	2" Replacement Top; 2 Poppet BSPT	Male	3.3
495671S	2" Replacement Top; 2 Poppet BSPT	Female	2.9
492963K	Fusible Link Kit		0.2
572417	Control Arm		
A0065-001	A0060 Stabilizer Bar Mounting Kit		3.8

Emergency Shear Valves

A0063EVR Vapor Shear Valve

The Emco Wheaton A0063EVR Vapor Shear Valve installs on vapor recovery lines under the dispenser to eliminate the escape of vapors in the event of a collision to the dispenser. The double poppet valve incorporates a 1.5" female NPT connection to the underground piping and a 1" female NPT connection to dispenser piping. The valve incorporates a 3/8" test port. The A0063EVR is approved for use with all CARB certified pre-EVR and EVR Phase II vapor recovery systems. Includes 5 anchoring bolts, washers and nuts. Does not include plate or U-bolts. If required, order the A0065-001 Mounting Kit, below.



A0063EVR-024

Model No.	Description	Inlet	Outlet	Lbs
A0063EVR-024	1 1/2" Double Poppet	Female	Female	4.0

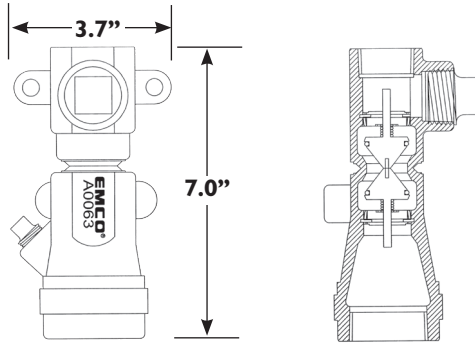

<p>Material Body: Cast Iron Spring: Stainless Steel Seal: Viton® Viton® is a registered trademark of The Chemours Company</p> <p>Approvals UL 841 Listed MH10206</p>

A0065 Mounting Kit

The Emco Wheaton A0065-001 Mounting Kit is used to mount the A0060 and A0063 to the dispenser pan stabilizer bar. The kit includes 2 U-bolts, 4 lock washers, 4 hex nuts, 3 flat head cap screws and mounting plate. Weighs 3.8 lbs.

To order the A0065 Mounting Kit with the A0060 Shear Valve, replace the first digit of the variant number with a 1. Example: A0060-102, single poppet male with mounting kit.



495645 Mounting Kit

The Emco Wheaton 495645 Mounting Kit is used to mount the A0060 directly to the Unistrut™. The kit includes 1 mounting bracket, 3 flat head cap screws, 2 bolts and 2 Unistrut™ channel nuts. Weighs 1.3 lbs.

Unistrut™ is a trademark of Unistrut Corporation

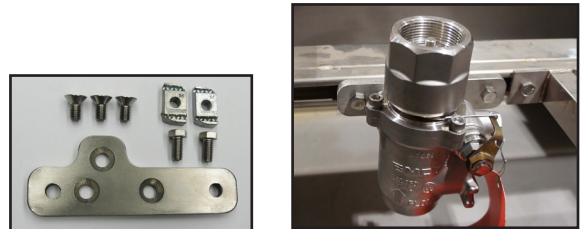

Overfill Prevention Valve

A1100 Overfill Prevention Valve

The Emco Wheaton A1100 is a two stage overfill prevention valve for use in both dual point and coaxial drop tubes, gravity feed systems. Easily installs in a new or existing drop tube assembly for economical compliance with EPA regulations. Internal float design to eliminate any chance of the floats getting caught on tank walls or the riser pipe as well as to prevent float damage during installation. Stick diverter and automatic spring loaded poppet retract from the flow path when the valve is not in operation, allowing for stick gauging at any tank level. Compatible with all standard fuels. Special variants are available for most bulk chemical applications.

- **Drain Bleed Valve** for hose drainage, reduces unnecessary delays. Spring loaded and includes soft seat for positive seal
- **Protective Retainer** over floats for protection during installation, shipping and operation
- **Cast-in Dip Stick Diverters** permit stick gauging at any tank level without damage to internal parts
- **Vertical Slide Float Design** for protection during installation
- **Auto Relatch** prevents premature shut-off
- **Integrated Body Design** suitable for both dual point and coaxial drop tubes - one valve for all applications
- **Shock Relief Valve** incorporated to reduce line shock
- **Viton® O-Rings** at base of valve seals drop tube to valve to protect against leakage

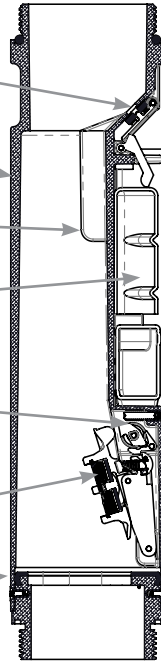

Material

Body: Aluminum
 Floats: HDPE
 Seals: Viton®

Viton® is a registered trademark of The Chemours Company

Specifications

Weight: 5.2 lbs.
 Diameter: 3.76"
 Length: 18.0"

Approvals

UL 2583 Listed (MH21164)
 UL 2583B
 Florida DEP EQ-414
 CARB Executive Order VR-105
 EPA 40 CFR Part 63 Compliant

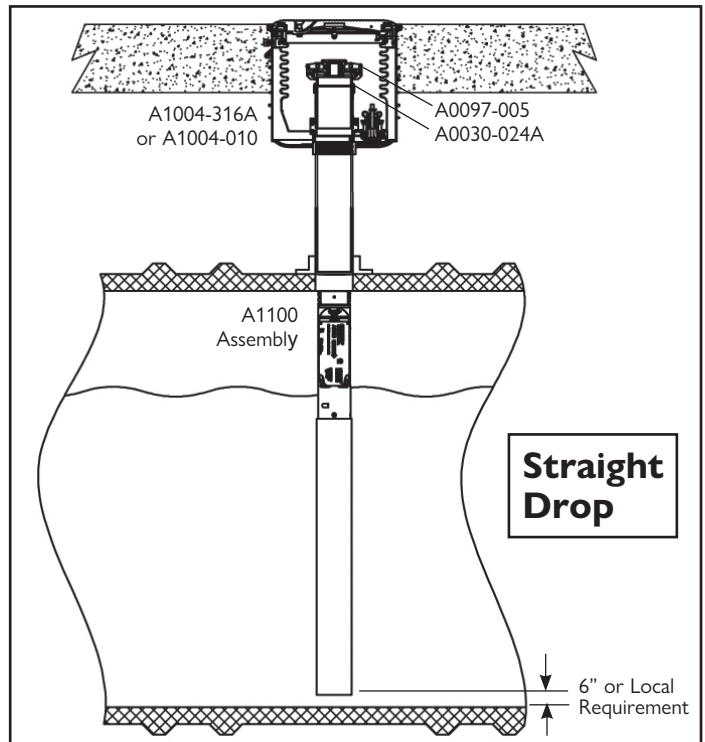

Overfill Prevention Valve

A1100 Standard Dual Point Overfill Prevention Systems

All Emco Wheaton assemblies are factory welded. The bottom tube screws together with the valve/top tube assembly.

All assemblies are vapor tight and meet EPA 40 CFR Part 63 requirements. No epoxy needed. All standard A1100 variants are acceptable for use with up to E85 ethanol blend gasoline and B100 biodiesel blends. Emco "E" variant OPV's are recommended when working with high percentage ethanol (E85) or biodiesel (B100) fuels. All OPV's are available with anodized top tubes (champagne color for easy identification) to prevent corrosion build-up between the drop tube and the riser pipe.

Model No.	Description
493192	Valve to Tube Rivet Assembly Kit
493436	Remote Fill Kit Non-EPA
493734A	Riser Collar Kit, Anodized
493734E	Riser Collar Kit
493734E85	Riser Collar Kit, Anodized, E85
493734SXL	Riser Collar Kit Extended 10.7"
493734SXXL	Riser Collar Kit Extended 20.7"
496360	Upright Functional Test Tool Kit
566675	Drill Fixture, Steel
571814	Drill Fixture, Remote Fill Assemblies
572719	Drill Fixture, Plastic
A0379-001	Remote Fill Cage Adjustable NPSM
A0379-101	Remote Fill Cage Adjustable BSPP

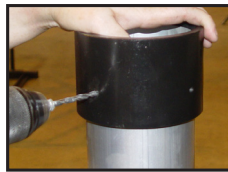

Drill Fixture
Aligns holes for attaching support collar

566675: Steel
572719: Plastic
571814: Remote Fill Only



496360- A1100 Upright Functional Test Kit.
Scan for video instructions of the A1100 Upright Functional Test.

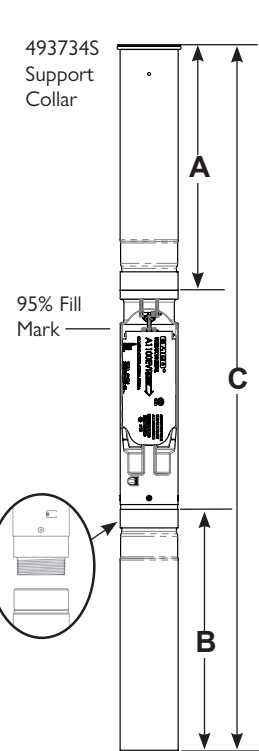

Model No.	Description	Lengths			Max Burial Depth	Tank Dia.	Lbs.
		Top "A"	Bottom "B"	Overall "C"			
A1100-010	Valve Only	N/A	N/A	N/A	N/A	N/A	5.2
A1100-011	Valve Only Remote Fill	N/A	N/A	N/A	N/A	N/A	5.0
A1100-054S	Remote Fill Export	47"	100"	161"	N/A	N/A	28.5
A1100-054SC	Remote Fill w/Cage BSPT	47"	100"	161"	N/A	N/A	27.9
A1100-054SCN	Remote Fill w/Cage NPT	47"	100"	161"	N/A	N/A	25.0
A1100-056SERF	Remote Fill Kit, Buried E85/B100	82"	95"	199"	4.0**	10.0'	66.5
A1100-056SRF	Remote Fill Kit, Buried	82"	95"	199"	4.0**	10.0'	66.5
A1100-056SERFK	Remote Fill Kit, Sump E85/B100	82"	95"	191"	--	10.0'	40.7
A1100-056SRFK	Remote Fill Kit, Sump	82"	95"	191"	--	10.0'	40.7
A1100-053S	Dual Pt Screw Together	58"	50"	122"	5.0'	6.5'	22.1
A1100EVR-055	Dual Pt Screw Together	70"	83"	167"	6.0'	8.0'	25.2
* A1100EVR-055CF	Dual Pt Screw Together	70"	83"	167"	6.0'	8.0'	25.2
A1100EVR-056	Dual Pt Screw Together	82"	95"	191"	7.0'	10.0'	27.2
* A1100EVR-056CF	Dual Pt Screw Together	82"	95"	191"	7.0'	10.0'	27.2
A1100EVR-057	Dual Pt Screw Together	82"	121"	217"	6.8'	12.0'	30.3
A1100EVR-057E	Dual Pt Screw Together E85/B100	82"	121"	217"	6.8'	12.0'	30.5
A1100EVR-058	Dual Pt Screw Together	120"	121"	255"	10.0'	12.0'	31.0
* A1100EVR-058CF	Dual Pt Screw Together	120"	121"	255"	10.0'	12.0'	31.0

The A1100 Overfill Prevention Valve is not recommended for tanks under 6.5' in diameter.

Maximum burial depth assumes 95% shut-off and 6" clearance between top of drop tube and inside bottom of containment manhole lid.

* Anodized top tube

** **SRF variants are designed for precise burial depth of 46"-54"; tank top access required.** For additional applications and installation instructions, call Customer Service at 800-234-4394.

OPV systems can be ordered as a package with a fill cap and fill adapter. Contact Customer Service for ordering information. Custom lengths available.

Overfill Prevention Valve

A1100 Modular Dual Point Overfill Prevention Systems

MODULAR DUAL POINT OPV

The highly customizable Modular Overfill Prevention Valve easily accommodates upgrades and mitigates installation errors. Additionally, the modular assembly ships in a 5'4" box alleviating steep shipping costs for both new OPVs and replacement parts while also fitting perfectly in a standard truck bed.

All assemblies are vapor tight and meet EPA 40 CFR Part 63 requirements. No epoxy needed. All standard A1100 variants are acceptable for use with up to E85 ethanol blend gasoline and B100 biodiesel blends. Emco "E" variant OPV's are recommended when working with high percentage ethanol (E85) or biodiesel (B100) fuels.

All OPVs are available with anodized top tubes (champagne color for easy identification) to prevent corrosion build-up between the drop tube and the riser pipe.

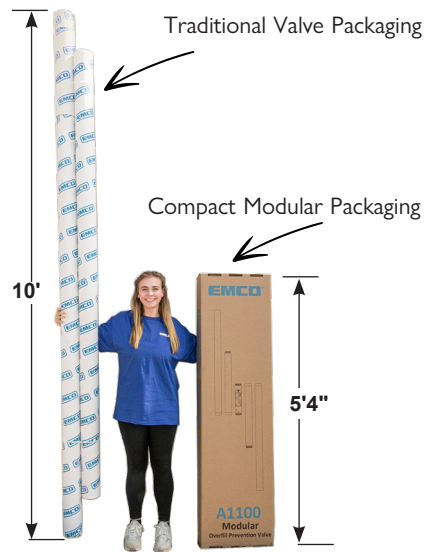

Model No.	Description	Lengths			Max Burial Depth	Tank Dia.	Lbs.
		Top "A"	Bottom "B"	Overall "C"			
A1100EVR-055M	OPV 13', Modular	60"	84"	161"	5'	8'	24
A1100EVR-055CFM	OPV 13', Modular, Anodized	60"	84"	161"	5'	8'	24
A1100EVR-055TCFM	OPV 13', Modular, Anodized, Testable	60"	84"	161"	5'	8'	24
A1100EVR-055TEM	OPV 13', Modular, Anodized, Testable, E85/B100	60"	84"	161"	5'	8'	24
A1100EVR-056M	OPV 17', Modular	96"	96"	209"	8'	10'	28
A1100EVR-056CFM	OPV 17', Modular, Anodized	96"	96"	209"	8'	10'	28
A1100EVR-056TM	OPV 17', Modular, Testable	96"	96"	209"	8'	10'	28
A1100EVR-057M	OPV 19', Modular	96"	120"	233"	8'	12'	30
A1100EVR-057TCFM	OPV 19', Modular, Anodized, Testable	96"	120"	233"	8'	12'	30
A1100EVR-058M	OPV 21', Modular	120"	120"	257"	10'	12'	32
A1100EVR-058EM	OPV 21', Modular, Anodized, E85/B100	120"	120"	257"	10'	12'	32
A1100EVR-058TEM	OPV 21', Modular, Anodized, Testable, E85/B100	120"	120"	257"	10'	12'	32

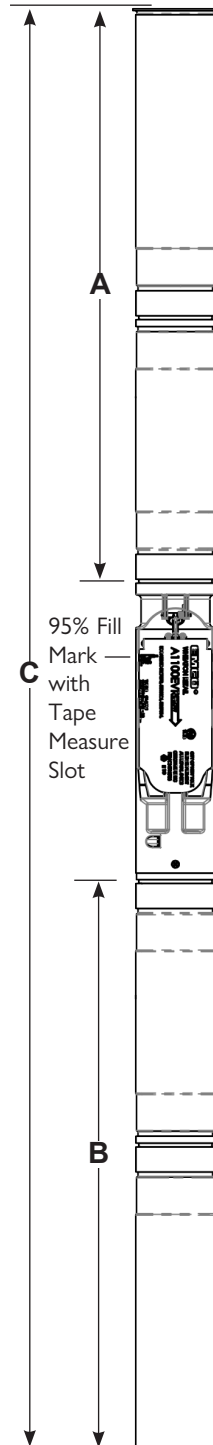

Replacement Parts

Change is easy with the Modular Overfill Prevention Valve. Adapt an 8' tank model OPV to a 10' tank model OPV by ordering one single tube; no need to return the entire OPV! Incorrect cuts no longer require a costly fix; order a replacement tube, switch out the unsuitable tube section, and cut to the correct length.

Top and Bottom Tubes

Model No.	Description
496400-24D	24", Dual Coupling
496400-24DA	24", Dual Coupling, Anodized
496400-36D	36", Dual Coupling
496400-36DA	36", Dual Coupling, Anodized
496400-60S	60", Single Coupling (Female)
496400-60SA	60", Single Coupling (Female), Anodized
496400-60D	60", Dual Coupling
496400-60DA	60", Dual Coupling, Anodized

All tubes include the 568348 o-rings for attaching to the A1100 Valve.

Collar Kits

Model No.	Description
493734E	Riser Collar Kit
493734A	Riser Collar Kit, Anodized
493734E85	Riser Collar Kit, Anodized, E85/B100
569461	Top Collar O-Ring
568348	Modular Tube Joint O-Ring

Valve Only

Model No.	Description
A1100EVR-010M	Valve Only, Modular
A1100EVR-010TM	Valve Only, Testable, Modular
A1100EVR-010EM	Valve Only, E85, Modular
A1100EVR-010TEM	Valve Only, Testable, E85/B100, Modular

Above valves include the 568348 o-rings for top and bottom screw parts.



Overfill Prevention Valve

A1100 Modular Dual Point Overfill Prevention Systems

Use the table below to compare standard Emco OPV's to their Emco modular equivalent.

Emco Cross Reference			
Conventional Part No.	Description	Modular Part No.	Description
A1100-053S	OPV 10.5'	A1100EVR-055M	OPV 13', Modular
A1100EVR-055	OPV 13'		
A1100EVR-055CF	OPV 13', Anodized	A1100EVR-055CFM	OPV 13', Modular, Anodized
A1100EVR-055T	OPV 13', Testable	A1100EVR-055TCFM	OPV 13', Modular, Anodized, Testable
A1100EVR-055TCF	OPV 13', Anodized, Testable		
A1100EVR-056	OPV 15'	A1100EVR-056M	OPV 17', Modular
A1100EVR-056CF	OPV 15', Anodized	A1100EVR-056CFM	OPV 17', Modular, Anodized
A1100EVR-056T	OPV 15', Testable	A1100EVR-056TM	OPV 17', Modular, Testable
A1100EVR-057	OPV 18'	A1100EVR-057M	OPV 19', Modular
A1100EVR-056TCF	OPV 15', Anodized, Testable	A1100EVR-057TCFM	OPV 19', Modular, Anodized, Testable
A1100EVR-057CF	OPV 18', Anodized		
A1100EVR-057TCF	OPV 18', Anodized, Testable		
A1100EVR-057T	OPV 18', Testable		
A1100EVR-058	OPV 21'	A1100EVR-058M	OPV 21', Modular
A1100EVR-058CF	OPV 21', Anodized		
A1100EVR-056E	OPV 15', E85/B100	A1100EVR-058EM	OPV 21', Modular, Anodized, E85/B100
A1100EVR-057E	OPV 18', E85/B100		
A1100EVR-057TE	OPV 18', Testable, E85/B100	A1100EVR-058TEM	OPV 21', Modular, Anodized, Testable, E85/B100

Use the table below to compare standard competitor OPV's to their Emco modular equivalent.

Competitor Cross Reference			
OPW Part No.	Description	Emco Modular Part No.	Description
71SO-4000	71SO OPV 5' Bury, 8' Tank	A1100EVR-055M	OPV 13', Modular
71SO-400C	4" OPV 5' Bury, 8' Tank, Vapor Tight	A1100EVR-055M	OPV 13', Modular
71SO-400CB	4" OPV 5' Bury, 8' Tank, Vapor Tight, B100	A1100EVR-055TEM	OPV 13', Modular, Anodized, Testable, E85/B100
71SO-400CT	4" OPV 5' Bury, 8' Tank, Vapor Tight Testable	A1100EVR-055TCFM	OPV 13', Modular, Anodized, Testable
71SO-400CTB	4" OPV 5' Bury, 8' Tank, Vapor Tight Testable, B100	A1100EVR-055TEM	OPV 13', Modular, Anodized, Testable, E85/B100
71SO-4010	71SO OPV 10' Bury, 10' Tank	A1100EVR-056M	OPV 17', Modular
71SO-410C	4" OPV 10' Bury, 10' Tank, Vapor Tight	A1100EVR-056M	OPV 17', Modular
71SO-410CB	4" OPV 10' Bury, 10' Tank, Vapor Tight, B100	A1100EVR-058EM	OPV 21', Modular, Anodized, E85/B100
71SO-410CT	4" OPV 10' Bury, 10' Tank, Vapor Tight, Testable	A1100EVR-056TM	OPV 17', Modular, Testable
71SO-410CTB	4" OPV 10' Bury, 10' Tank, Vapor Tight, Testable, B100	A1100EVR-058TEM	OPV 21', Modular, Anodized, Testable, E85/B100
71SO-420C	Vapor Tight OPV 10' Bury, 12' Tank	A1100EVR-058M	OPV 21', Modular
71SO-420CB	4" OPV 10' Bury, 12' Tank, Vapor Tight, B100	A1100EVR-058EM	OPV 21', Modular, Anodized, E85
71SO-420CT	Vapor Tight OPV 10' Bury, 12' Tank, Testable	A1100EVR-058TEM	OPV 21', Modular, Anodized, Testable, E85/B100
71SO-420CTB	4" OPV 10' Bury, 12' Tank, Vapor Tight, Testable, B100	A1100EVR-058TEM	OPV 21', Modular, Anodized, Testable, E85/B100
71SOM-412C	Vapor Tight OPV for Alcohol 10' Bury, 10' Tank, E85	A1100EVR-058EM	OPV 21', Modular, Anodized, E85/B100
Franklin Part No.			
708691901	Dual Pt, OPV, 5' Top/8' Bottom	A1100EVR-055TCFM	OPV 13', Modular, Anodized, Testable
708691902	Dual Pt, OPV, 5' Top/10' Bottom	A1100EVR-056TM	OPV 17', Modular, Testable
708691921	Dual Pt, OPV, 5' Top/8' Bottom-AGB	A1100EVR-055TEM	OPV 13', Modular, Anodized, Testable, E85/B100
708691922	Dual Pt, OPV, 5' Top/10' Bottom-AGB	A1100EVR-058TEM	OPV 21', Modular, Anodized, Testable, E85/B100
708692901	Dual Pt, OPV, 10' Top/8' Bottom	A1100EVR-056TM	OPV 17', Modular, Testable
708692902	Dual Pt, OPV, 10' Top/10' Bottom	A1100EVR-058TEM	OPV 21', Modular, Anodized, Testable, E85/B100
708692921	Dual Pt, OPV, 10' Top/8' Bottom-AGB	A1100EVR-058TEM	OPV 21', Modular, Anodized, Testable, E85/B100
708692922	Dual Pt, OPV, 10' Top/10' Bottom-AGB	A1100EVR-058TEM	OPV 21', Modular, Anodized, Testable, E85/B100

Overfill Prevention Valve

A1100 Testable Overfill Prevention Systems

The Emco Wheaton A1100-T Testable Overfill Prevention Valve allows for quick and easy testing without removing the valve from the tank riser. Simply use the A0081-1100 Testing Rod to depress the test button installed on the valve, and shine a light inside the valve - if the reflective tape is visible, the valve is operational.

The testable A1100-T OPV uses the same proven technology as the A1100 OPV Series. Assemblies are factory welded and 100% factory tested. Bottom tube screws to top tube/valve assembly - No Epoxy. This saves time in the field and assures a vapor tight assembly to meet the EPA 40 CFR Part 63 requirements.

Available with anodized top tube to prevent corrosion.

Testable Feature

Use the Emco A0081-1100 Testing Rod to depress test button and linkage.

Shine light down interior of valve (alternatively, snap a photo). If reflective tape is visible, valve is OK.



Valve in Nominal Position



Valve in Pressed Position

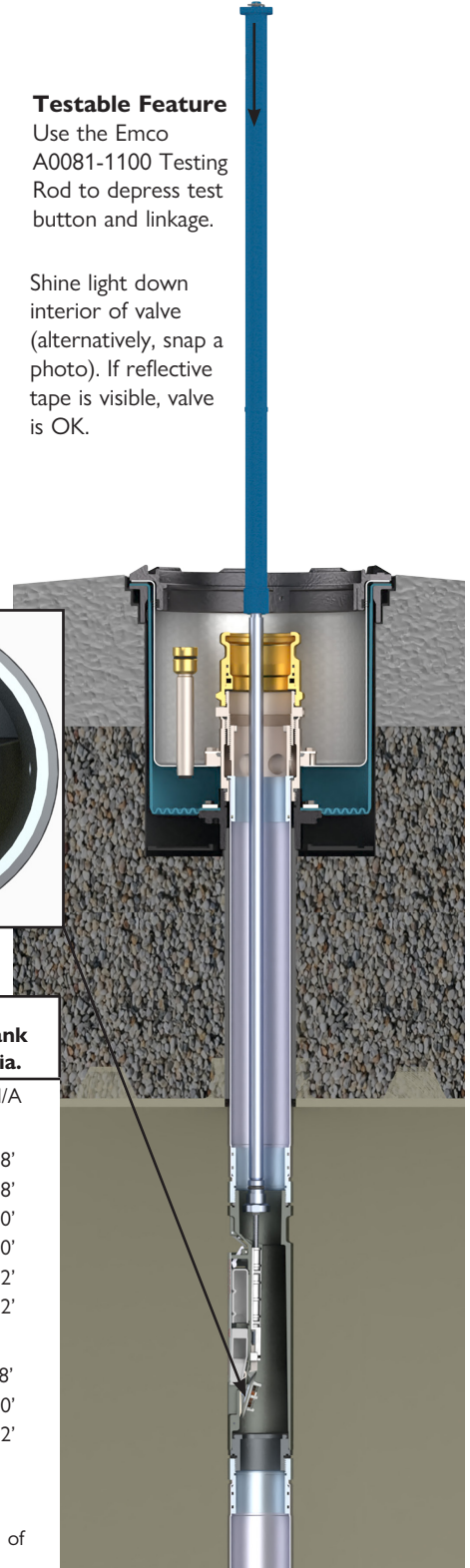
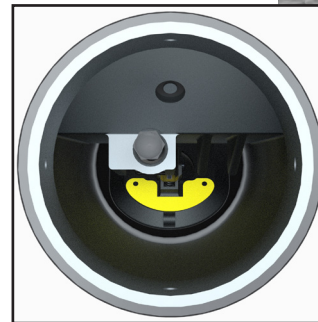

Model No.	Description	Length			Max. Burial Depth	Tank Dia.
		Top "A"	Bottom "B"	Overall "C"		
A1100-010T	Testable Valve Only	N/A	N/A	N/A	N/A	N/A
Dual Point						
A1100EVR-055T	Testable Vapor-Tight OPV	70"	82"	167"	6.0'	8'
*A1100EVR-055TCF	Testable Vapor-Tight OPV	70"	82"	167"	6.0'	8'
A1100EVR-056T	Testable Vapor-Tight OPV	82"	92"	191"	7.0'	10'
*A1100EVR-056TCF	Testable Vapor-Tight OPV	82"	92"	191"	7.0'	10'
A1100EVR-057T	Testable Vapor-Tight OPV	82"	120"	217"	6.8'	12'
*A1100EVR-057TCF	Testable Vapor-Tight OPV	82"	120"	217"	6.8'	12'
Coaxial - Self-Sealing (Adapter & cap included)						
A1100-085TP	Testable Vapor-Tight OPV	65"	82"	162"	5.4'	8'
A1100-086TP	Testable Vapor-Tight OPV	65"	94"	174"	5.3'	10'
A1100-087TP	Testable Vapor-Tight OPV	65"	120"	200"	5.1'	12'

*Anodized top tube

The A1100 Overfill Prevention Valve is not recommended for tanks under 6.5' in diameter.

Maximum burial depth assumes 95% shut-off and 6" clearance between top of drop tube and inside bottom of containment manhole lid.

Overfill Prevention Valve

A1100 Coaxial Overfill Prevention Systems

Emco Self Sealing OPVs meet EPA 40 CFR Part 63 requirements. All 1100 variants are acceptable for use with up to E85 ethanol blend gasoline and B100 biodiesel blends. Emco "E" variant OPVs are recommended when working with high percentage ethanol (E85) or biodiesel (B100) fuels. A1100 coaxial assemblies are not compatible with the Emco 494096 Riser Seal.

Note: Emco Coaxial OPVs must be used with Emco A0089/A0096 Fill Adapter.

Coaxial Self-Sealing



MODULAR COAXIAL OPV

Emco Coaxial OPVs are now available in a one size fits all Modular configuration.

What's Included:

- Overfill Prevention Valve
- 3 1/4" x 60" Top Tube with Centering Ring
- 4" x 60" Dual Base Bottom Tube
- 4" x 60" Single Base Bottom Tube
- Collar Kit (Self Sealing or Non-EPA)
- Coaxial Adapter (Self Sealing or Non-EPA)

Replacement Components

- A0089-001 Coax Self Sealing Adapter
- A0089-001E Coax Self Sealing Adapter, E85
- A0096-001 Coax Non-EPA Adapter
- 493197 Coax Self Sealing Collar Kit
- 493195 Coax Non-EPA Collar Kit
- A1100EVR-010M Replacement OPV, Valve Only

Accessory Components

- A0081-001 Adapter Wrench | A0032-001 Adapter Clamp | A0097-005 Fill Cap



A1100-097

Shipping dimensions:
5" x 18" x 65"

Emco/Competitor Modular Cross Reference

A1100-077

Coaxial OPV, Modular, Non-EPA

Replaces	Emco	Franklin	Description
	A1100-06_S		Coaxial OPV, Non-EPA, All Sizes
	OPW 61SOC-4001		Coax OPV, 60" top tube, 83" bottom tube
	OPW 61SOC-4011		Coax OPV, 120" top tube, 102" bottom tube
	Franklin 708693901		Defender Series® Coax OPV, 78" top tube, 96" bottom tube
	Franklin 708693902		Defender Series® Coax OPV, 78" top tube, 120" bottom tube

A1100-097

Coaxial OPV, Modular, Self Sealing

Replaces	Emco	OPW	Description
	A1100-08_S		Coaxial OPV, Self Sealing, All Sizes
	OPW 61SOP-4002		Poppeted Coax OPV, 60" top tube 83" bottom tube
	OPW 61SOP-4012		Poppeted Coax OPV, 120" top tube 102" bottom tube

A1100-097E

Coaxial OPV, Modular, Self Sealing, E85/B100

Replaces	Emco	Franklin	Description
	A1100-08_E		Coaxial OPV Self Sealing, E85, All Sizes
	Franklin 708693923		Defender Series® Poppeted Coax OPV, 78" top, 96" bottom, AGB
	Franklin 708693924		Defender Series® Poppeted Coax OPV, 78" top, 120" bottom, AGB

Model No.	Description	Length			Max. Burial Depth	Tank Dia.
		Top Tube	Bottom Tube	Overall Height		
Modular						
A1100-077	Coaxial, Modular, Non-EPA	60"	120"	197"	5'	12'
A1100-097	Coaxial, Modular, Self Sealing	60"	120"	197"	5'	12'
A1100-097E	Coaxial, Modular, Self Sealing, E85/B100	60"	120"	197"	5'	12'
Conventional						
A1100-065S	Coaxial, Non-EPA	65"	82"	162"	5.6'	8'
A1100-066S	Coaxial, Non-EPA	65"	94"	174"	5.5'	10'
A1100-067S	Coaxial, Non-EPA	65"	120"	200"	5.3'	12'
A1100-085S	Coaxial, Self-Sealing	65"	82"	162"	5.4'	8'
A1100-085SP	Coaxial, Self-Sealing,, Cap/Adapter	65"	82"	162"	5.4'	8'
A1100-086S	Coaxial, Self-Sealing	65"	94"	174"	5.3'	10'
A1100-086SP	Coaxial, Self-Sealing, Cap/Adapter	65"	94"	174"	5.3'	10'
A1100-087S	Coaxial, Self-Sealing	65"	120"	200"	5.1'	12'
A1100-087SP	Coaxial, Self-Sealing, Cap/Adapter	65"	120"	200"	5.1'	12'
A1100-087E	Coaxial, Self-Sealing, E85/B100	65"	120"	200"	5.1'	12'

The A1100 Overfill Prevention Valve is not recommended for tanks under 6.5' in diameter.

Overfill Prevention Valve

A1100 Remote Fill Overfill Prevention Systems

Remote fill is used when the fill point is not directly over the underground storage tank. A typical remote fill installation includes a single wall spill container installed directly over the UST for tank gauging purposes. The Overfill Prevention Valve is installed into this spill container with a remote fill cage mounted into the upper tube; this cage aligns with and seals against the tee connected to the fuel drop point forcing fuel through the OPV. Build out your system with individual parts or order the A1100-056RF Remote Fill OPV Kit which includes everything you need to get started.

Part Number	Description
A1100-056RF	Remote Fill OPV Kit, 10' Tank
L A0097-005	Fill Adapter Cap
L A0030-024	Fill Adapter, Brass
L A0479-001	Auxiliary Tank Gauge Stick Port
L A0079-444SS	Remote Fill Tee, Stainless Steel
L 493436	Remote Fill Cage
L A1100EVR-056	Overfill Prevention Valve, 7' Bury/10' Tank Dia.

The spill container, riser seal, and riser pipes are not included in this kit.

Need To Know

- » This remote fill system is vapor tight and EPA 40 Part 63 compliant. This system is not CARB EVR approved; for the CARB EVR approved remote fill solution, see pg. 23.
- » This system requires the use of Emco A7901 4.1" controlled ID pipe nipples or equivalent. Schedule 40 seam welded riser pipe will not seal with this configuration.

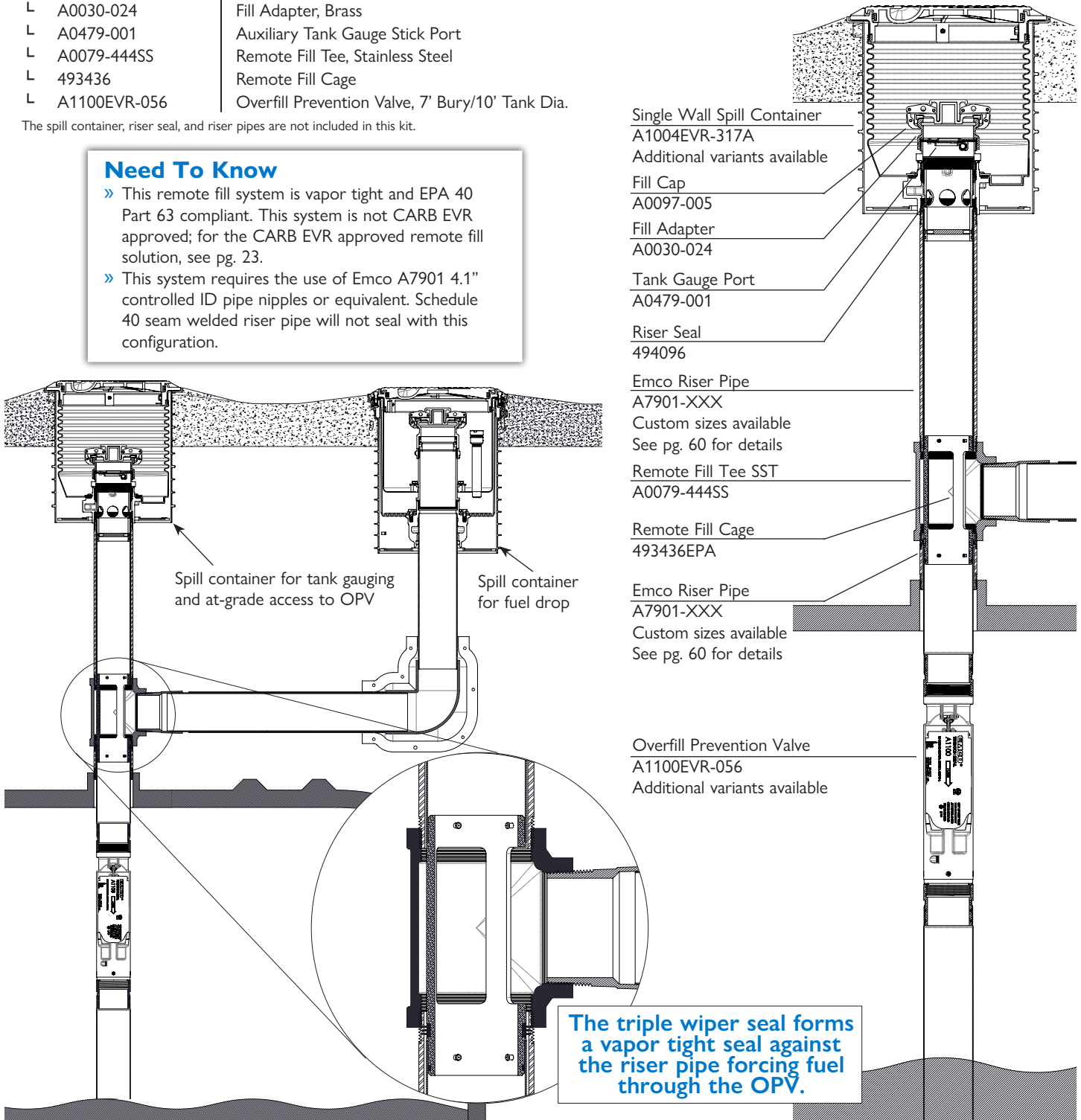

Overfill Prevention Valve

A1100 Remote Fill Overfill Prevention Systems

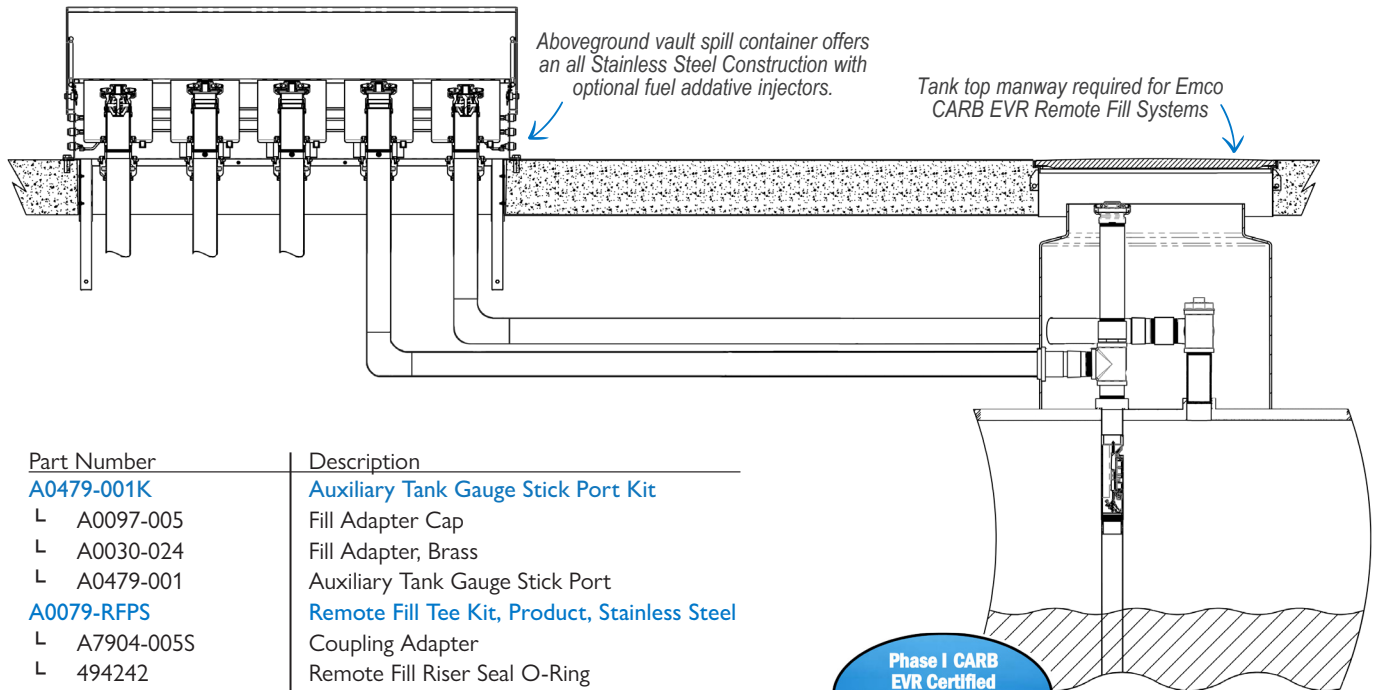

Part Number	Description
A0479-001K	Auxiliary Tank Gauge Stick Port Kit
L A0097-005	Fill Adapter Cap
L A0030-024	Fill Adapter, Brass
L A0479-001	Auxiliary Tank Gauge Stick Port
A0079-RFPS	Remote Fill Tee Kit, Product, Stainless Steel
L A7904-005S	Coupling Adapter
L 494242	Remote Fill Riser Seal O-Ring
L 494096R	Remote Fill Riser Seal and Cage
L A0079-444SS	Remote Fill Tee, Stainless Steel
A0079-RFVS	Remote Fill Tee Kit, Vapor, Stainless Steel
L A7900-004H	Male Pipe Plug with O-Ring
L A0079-444SS	Remote Fill Tee, Stainless Steel
A1100EVR-057M	OPV with Collar Kit
A1004EVR-317SSQR400	Spill Containment

All Emco CARB EVR approved spill containment solutions are available in a remote fill configuration; the most common spill containment solution is the A1004EVR-317SSQR400. Similarly, All Emco CARB EVR approved OPVs can be installed into the remote fill system; the most common OPV for this application is the A1100EVR-057M.

Fill Cap
A0097-005

Fill Adapter
A0030-024

Tank Gauge Port
A0479-001

Emco Riser Pipe
A7901-XXX
Custom sizes available
See pg. 60 for details

Coupling Adapter
A7904-005S

Riser Seal
494096

Male Pipe Plug
A7900-004H

Remote Fill Tee SST
A0079-444SS

Emco Riser Pipe
A7901-XXX
Custom sizes available
See pg. 60 for details

Fill Line Tee

Vapor Line Tee

All Emco remote fill systems are compatible with:

- 4" Double Wall FRP
- 4" Single Wall FRP
- 6" over 4" FRP
- 3" Double Wall FRP*
- 3" Single Wall FRP*
- 4" over 3" FRP*

*Not CARB EVR compliant

Drop Tubes

A0020 Drop Tube

The Emco Wheaton A0020 Drop Tube is designed for use in both non-vapor recovery and dual point vapor recovery systems. Emco drop tubes are .05" thick for added strength and to reduce shipping damage. Tube I.D. is 3.815". Custom lengths are available upon request.

Model No.	Size	Length	Style	Lbs.
Rolled Edge				
A0020EVR-004	4"	12'	Conventional	13.0
A0020EVR-005	4"	15'	Conventional	16.1
A0020EVR-005M	4"	15'	Modular	17.0
Heavy Duty Collar				
A0020EVRC-004	4"	12'	Conventional	13.7
A0020EVRC-005	4"	15'	Conventional	16.8
A0020EVRC-005M	4"	15'	Modular	20.1
*A0020EVRC-005ME	4"	15'	Modular	20.1
A0020EVRC-007M	4"	20'	Modular	23.1

Emco recommends the heavy duty collar option for EVR applications.

*Acceptable for E85/B100 Applications

Model No.	Description	Lbs.
493391	Riser Collar Kit w/ Handle	2.0
493391A	Riser Collar Kit	2.0
569461	Collar O-ring	

Material
 Tube: Aluminum
 O-Ring: Viton®
 Viton® is a registered trademark of The Chemours Company

Approvals
 CARB Executive Order VR-105



COLLAR OPTIONS:



Standard rolled edge

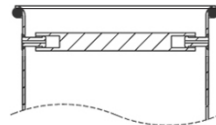

Standard rolled edge with handle

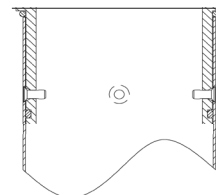

Heavy duty collar

MODULAR DROP TUBES

Emco's new modular A0020 drop tubes are much more cost effective to ship and warehouse.

← **Conventional A0020**
Modular A0020



A0020EVRC-007M

Shipping dimensions:
 5" x 18" x 65"



493391
 Riser Collar Kit
 Includes Handle



493391A
 Riser Collar Kit



Drop Tubes

A0070/A0088 Coaxial Drop Tubes

The Emco Wheaton A0070 Drop Tube is used for coaxial fill systems. The A0070 is not self-sealing. The tube design is narrow at the top but flares out to a standard tube size in the middle.

Emco Wheaton's exclusive A0088 Drop Tube is used in coaxial fill systems to provide a self-sealing vapor line. The spring-loaded assembly secures the tube against the adapter during normal storage.

Custom lengths are available upon request.

Material

Tube: Aluminum

Model No.	Size	I.D.	O.D.	Length	Lbs.
A0070-101	4"	3.125"	3.240"	12'	12.3
A0070-116	4"	3.125"	3.240"	16'	15.9
A0088-101	4"	3.125"	3.240"	12'	12.4
*A0088-101A	4"	3.125"	3.240"	12'	14.0
A0088-116	4"	3.125"	3.240"	12'	16.0

*Includes A0089-001 Fill Adapter

	A0070	A0088
Coax Collar Kit	493195	493197
Fill Adapter	A0096-001	A0089-001
Fill Cap	A0097-005	A0097-005



493195 Coax Collar Kit
For A0070 Drop Tube



493197 Coax Collar Kit
For A0088 Drop Tube



A0070
Not Self-Sealing



A0088
Self-Sealing

■ CARB
Executive Order
G-70-97-A

Overfill Prevention Valve

Replacement Parts & Accessory Components

Collar Kits

Model No.	Description
493734E	Riser Collar Kit
493734A	Riser Collar Kit, Anodized
493734E85	Riser Collar Kit, Anodized, E85
493197	Coax Self Sealing Collar Kit
493195	Coax Non-EPA Collar Kit
569461	Top Collar O-Ring
568348	Modular Tube Joint O-Ring



Extended Collar Kits

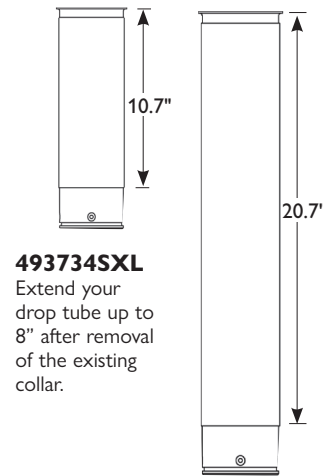

493734SXL
Extend your drop tube up to 8" after removal of the existing collar.

493734SXXL
Extend your drop tube up to 18" after removal of the existing collar.

Perfect for drop tube repairs or as a quick fix to OPV top tube cutting mistakes, these extended collar kits attach in place of a regular collar to add length to your drop tube. Available in multiple sizes and in anodized finish option to prevent corrosion buildup. All collar kits include: (4) rivets, (2) o-rings, Seal-all sealant, indent tool, drill fixture, stainless steel extension spring and warning plate



Replacement Valve Only



Model No.	Description
A1100EVR-010M	OPV Valve Only, Modular
A1100EVR-010TM	OPV Valve Only, Testable, Modular
A1100EVR-010EM	OPV Valve Only, E85, Modular
A1100EVR-010TEM	OPV Valve Only, Testable, E85, Modular

Replacement Modular Tubes

Model No.	Description
496400-24D	24", Dual Coupling
496400-24DA	24", Dual Coupling, Anodized
496400-36D	36", Dual Coupling
496400-36DA	36", Dual Coupling, Anodized
496400-60S	60", Single Coupling (Female)
496400-60SA	60", Single Coupling (Female), Anodized
496400-60D	60", Dual Coupling
496400-60DA	60", Dual Coupling, Anodized

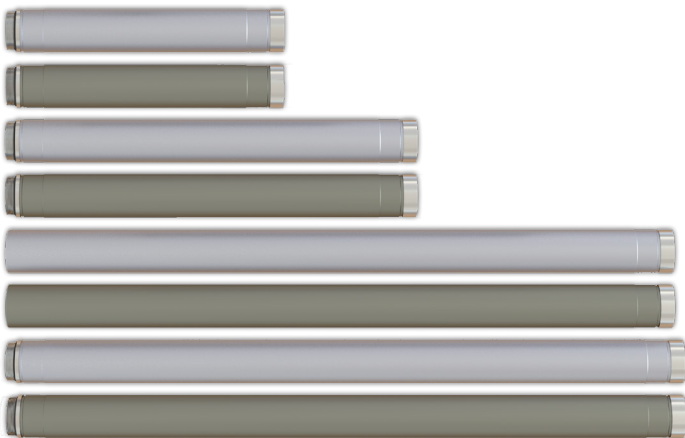

Coaxial Tube Assemblies

Top and bottom tube assemblies can be purchased separately:

Top tube assemblies include upper tube and valve assembly. Bottom tube assemblies include lower tube and bushing assembly.

Model No.	Description	Length
A1100-065ST	Top Tube Assembly	80"
A1100-085ST	Top Tube Assembly	80"
494406A	Bottom Tube Assembly	83"
494441A	Bottom Tube Assembly	95"
494341A	Bottom Tube Assembly	121"

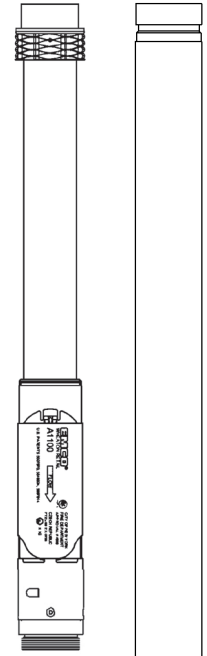

Top Tube Assembly Bottom Tube Assembly

A0066 Multi-Purpose Check Valve

Material

Body: Cast Iron
 Poppet: Brass
 Springs: Stainless Steel
 Seal: Viton®

Viton® is a registered trademark of The Chemours Company

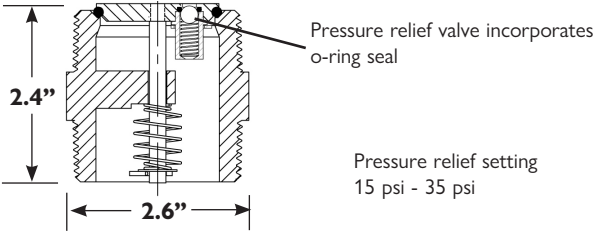

■ UL Listed MH10206

The Emco Wheaton A0066 Multi-Purpose Check Valve is designed to maintain prime and prevent unnecessary tripping of mechanical leak detectors. The A0066 is mounted at the submersible pump to relieve thermal expansion between the pump and dispenser. Vent poppet is designed to provide positive sealing and more accurate pressure relief settings. Heavy wall cast iron body construction.

Model No.	Size	Lbs.
A0066-020	2"	2.1

A0750 Ball Valve

Material

Body: Brass
 Seal: Teflon PTFE

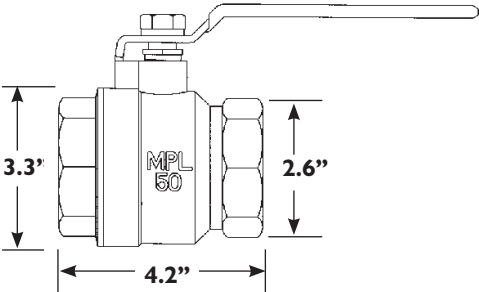

The Emco Wheaton A0750 Ball Valve is a full port 2" valve. Thread depth is .865"; inside diameter is 2". 150 psi working pressure.

Model No.	Size	Lbs.
A0750-200	2"	4.1

Extractor Fittings

A0079 Float Valve Extractor

The Emco Wheaton A0079 Extractor Assembly consists of a cast iron extractor body and an internal "bar style" cage. This cage holds any length of A0075 Ball Float (sold separately). The A0079 may be ordered with a variety of port combinations to accommodate tank venting and Stage II vapor recovery piping. The A0079 is also available without an extractor cage.

The A0079 Extractor Assemblies are available in Stainless Steel for compatibility with E85, DEF, and Bio-Diesel fuels.

The A0079 may be installed as part of the Emco Phase I EVR System without violating the Executive Order (VR-105)

Cross Style

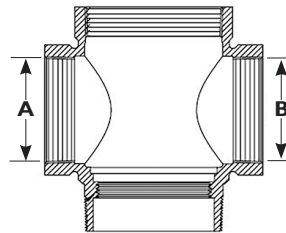

Tee Style

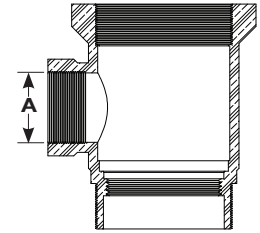

CARB Executive Order G-70-97-A
ULC MH24242

Model No.	Top/Bottom Threads	Outlet Threads A & B	Cage Thread	Lbs.
Cross Style				
A0079-050	4" NPT	2" x 2" NPT	N/A	8.5
A0079-020 with Cage	4" NPT	2" x 2" NPT	2" NPSM	10.7
A0079-051	4" NPT	3" x 2" NPT	N/A	10.8
A0079-051SS**	4" NPT	3" x 2" NPT	N/A	12.1
A0079-019 with Cage	4" NPT	3" x 2" NPT	2" NPSM	11.9
A0079-052	4" NPT	3" x 3" NPT	N/A	11.8
A0079-025 with Cage	4" NPT	3" x 3" NPT	2" NPSM	12.0
Tee Style				
A0079-150	4" NPT	2" NPT	N/A	7.1
A0079-150SS**	4" NPT	2" NPT	N/A	10.9
A0079-120 with Cage	4" NPT	2" NPT	2" NPSM	10.7
A0079-152	4" NPT	3" NPT	N/A	8.7
A0079-152SS**	4" NPT	3" NPT	N/A	10.5
A0079-119 with Cage	4" NPT	3" NPT	2" NPSM	8.5
Additional Tee Style Models				
Model No.	Top/Bottom Threads	Outlet Threads A	Cage Thread	Lbs.
A0079-444*	4" NPT	4" NPT	N/A	8.7
A0079-444M* (Male Base)	4" NPT	4" NPT	N/A	10.1
A0079-444SS* **	4" NPT	4" NPT	N/A	12.5



*Used in Remote Fill applications only; does not support a cage

**Stainless Steel

Extractor Fittings

Accessories

A0179 Extractor Cage

The Emco Wheaton A0179 Extractor Cage is designed with a 3" male thread and a 2" female thread for use with the Emco Wheaton A0079 Extractor Valve and A0075 Ball Float. Use with A0560-003 Bar Style Extractor Wrench.



Material

Body: Aluminum
 Handle: Steel
 O-ring: Buna-N

Model No.	Description	Lbs.
A0179-002	2" Extractor Cage	1.2

A0279 Extractor Cage Test Plug

The Emco Wheaton A0279 Extractor Cage Test Plug is designed for performing pressure decay tests on your underground piping and storage tank systems. Use with A0560-003 Bar Style Extractor Wrench.



Material

Body: Aluminum
 Handle: Steel
 O-ring: Buna-N
 Plug: Cast Iron

Model No.	Description	Lbs.
A0279-001	Test Plug	1.9

A0560 Extractor Wrench

Emco Wheaton Extractor Wrenches are required to install and remove the A0584 and A0585 pipe caps and appropriate angle check, foot, and float valve extractor cages. Two head styles are available - the historic Emco Wheaton Buckeye style wrench and the A0560-003, industry standard "bar style" wrench.



Model No.	Size	Lbs.	Extractor Pipe Cap	Extractor Fitting
A0560-001 Buckeye	1 1/2"	8.0		A0677-003
A0560-003 Bar Style	2"	9.3	A0585-003	A0079, A0179, A0279

A0585-003 Extractor Pipe Cap

The Emco Wheaton A0585-003 Bar Style Extractor Pipe Cap is designed to thread directly on the extractor access pipes. Requires the A0560-003 Bar Style Extractor Wrench.



Material

Body: Aluminum
 Handle: Steel
 O-ring: Buna-N

Model No.	Size	Lbs.
A0585-003	4" Female	0.8

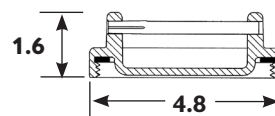

569924 Gasket Replacement Kit

Ball Floats

A0075 Ball Float

The Emco Wheaton A0075 Ball Float Valves are designed to restrict product flow in the event of a UST overfill. The A0075 meets EPA requirements for a slow down device.

Material

Tube: Aluminum
Ball: Stainless Steel

The A0075 may be installed as part of the Emco Phase I EVR System without violating the Executive Order (VR-105)

Model No.	Tube Diameter	Tube Length	Overall Length	Bleed Hole	Lbs.
*A0075-001	2"	4.75"	9.52"	.125"	1.2
A0075-002	2"	9.62"	14.39"	.125"	1.8
A0075-004	2"	8.00"	12.77"	.125"	1.6
A0075-006	2"	6.87"	11.64"	.062"	1.5
A0075-010	2"	18.00"	22.77"	.125"	2.8
A0075-015	2"	15.75"	20.75"	.125"	2.6
A0075-017	2"	17.75"	22.52"	.125"	2.8

*Most common variant. Custom lengths are available upon request.



■ CARB Executive Order G-70-97-A

A0078 Ball Float with Extractor Cage

The Emco Wheaton A0078 combination Ball Float and Extractor Valve Cage meet the EPA requirements for a 30 minute warning device.

The A0078 Ball Floats with cages are available with electroless nickel coating for compatibility with E85 fuels. The ball and spring are stainless steel. To order, add an E suffix to the part number.

Material

Tube: Aluminum
Ball: Stainless Steel

Model No.	Tube Diameter	Tube Length	Overall Length	Bleed Hole	Lbs.	Replaces OPW
A0078-006A	2"	6.75"	11.52"	.0625"	2.8	53VML-0060
A0078-008	2"	8.75"	13.52"	.0625"	3.2	
A0078-012A	2"	12.75"	17.52"	.0625"	5.3	53VML-0120
A0078-015	2"	15.75"	20.52"	.0625"	6.0	
*A0078-020	2"	20.50"	25.27"	.0625"	7.9	
A0078-021A	2"	21.75"	26.52"	.0625"	8.8	53VML-0210
A0078-312	3"	12.13"	16.27"	.0625"	4.5	

*Most common variant. Custom lengths are available upon request.

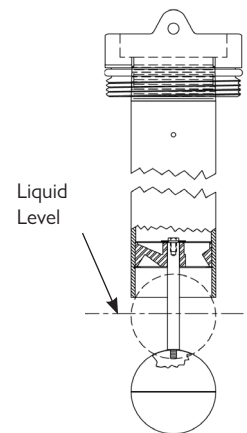

Product Identification

A0996, A0997, A0998 ID Markers & Tags

Emco Wheaton offers a complete line of fiberglass embedded, color coded ID tags and markers. The tags are easy to clean, maintain, and made to withstand extreme weather.

The A0996 Stick-on ID tag, 3.5" diameter, is for use on Emco spill containment; can also be used on some competitor manholes.

The A0997 Tank ID Tag attaches with spring tension to the storage tank fill pipe to identify the product grade, tank number and tank size.

The A0998 In-Ground ID Marker is used to identify the product grade in the underground tanks. The base is constructed of die cast aluminum for a smooth appearance. The lower profile with beveled edge minimizes tripping hazard.





































A0996 Spill Container ID Tag



A0997 Tank Riser ID Tag



A0998 In-Ground ID Marker

Product	A0996 Spill Container ID Tag	A0997 Tank Riser ID Tag	A0998 In-Ground ID Marker
Tank Monitor	 A0996-002	 A0997-080	 A0998-069
E0	 A0996-1EZ	N/A	N/A
Regular	 A0996-100	 A0997-032	 A0998-021
Mid-Grade	 A0996-200	 A0997-124	N/A
Premium	  A0996-300 A0996-302	 A0997-047	 A0998-016
Diesel	 A0996-400	 A0997-240	  A0998-027 A0998-018
E0-90	 A0996-301	 A0997-182	N/A
Kerosene	N/A	 A0997-048	 A0998-017
Vapor Recovery	 A0996-700	 A0997-059	 A0998-133
DEF	 A0996-DEF	 A0997-075	 A0998-050
E85 (85% Ethanol)	 A0996-E85	 A0997-049	 A0998-034
Unleaded	 A0996-UNL	 A0997-117	 A0998-014
E15 (15% Ethanol)	 A0996-E15	N/A	 A0998-039

A0997-002KIT Gallonage Kit

Includes eight tags

• 10,000 •	• 30,000 •
• 9,000 •	• 20,000 •
• 8,000 •	• 15,000 •
• 6,000 •	• 12,000 •

*also available in SST: A0997-002KIT-SS

A0997-002KIT-XX Custom Gallonage Kit



Stainless Steel, Laser Etched

Contact customer service for ordering information

All A0996, A0997 and A0998 ID tags are available with **custom etching** for specific product grade requirements.

The ID tag material is aluminum, anodized black and laser etched white.

Contact customer service at 800-234-4394 for ordering information.



A0996



A0997



A0998

Vents

A0084 Pressure Vacuum Vent

The Emco Wheaton A0084 is an internal pressure vacuum valve that restricts vapor escape during product drops. Typically installs on the top of the vent pipes from the underground or aboveground fuel storage tanks. The vent valve is equipped with a wire mesh screen designed to protect the storage tank vents against intrusion and blockage from rain water and debris. A normally closed poppet within the valve opens to allow the tank to vent (see chart below). The body and cap are anodized aluminum for corrosion-free service. UL Listed.



■ UL Listed MH46838

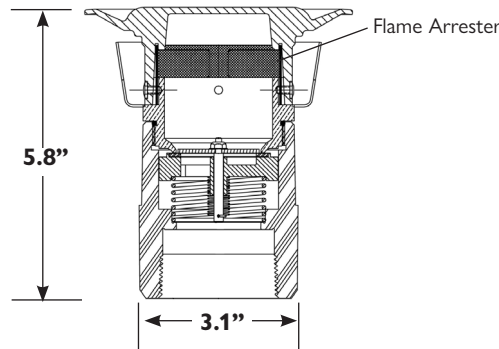

Material

- Body: Aluminum
- Seal: Viton®
- Cap: Aluminum
- Screen: 40 Mesh Stainless Steel

Viton® is a registered trademark of The Chemours Company

Model No.	Inlet	Pressure Setting	Vacuum Setting	Lbs.	Replaces
A0084-014	2" BSPT	13.86" H ₂ O (8.00 oz.)	0.8" H ₂ O (0.50 oz.)	2.6	
A0084-105	2" Slip On	2.00" H ₂ O (1.14 oz.)	0.8" H ₂ O (0.50 oz.)	2.0	
A0084-200	2" Thread-on	2.00" H ₂ O (1.14 oz.)	3.0" H ₂ O (1.88 oz.)	2.0	A0084-100
A0084-201	2" Slip On	2.00" H ₂ O (1.14 oz.)	3.0" H ₂ O (1.88 oz.)	2.6	A0084-101
A0084-204	2" Thread-on	13.86" H ₂ O (8.00 oz.)	0.8" H ₂ O (0.50 oz.)	2.9	A0084-004
A0084-209	2" Slip On	13.86" H ₂ O (8.00 oz.)	0.8" H ₂ O (0.50 oz.)	2.9	A0084-009
Meets EPA 40 CFR Part 63 Requirements					
* A0084-038	2" Thread-on	2.5"-6.0" WC	6.0"-10.0" WC	2.9	
A0084-103	2" Slip-on	2.5"-6.0" WC	6.0"-10.0" WC	2.6	
A0084-338	3" Thread-on	2.5"-6.0" WC	6.0"-10.0" WC	3.5	
A0084-303	3" Slip-on	2.5"-6.0" WC	6.0"-10.0" WC	3.2	

*Most common variant

A0085 Vent Adapters

The Emco A0085 is used with A0084 2" vents to connect to 3" riser pipes. Available in thread-on and slip-on versions. Aluminum construction.

Material

- Body: Aluminum
- Seal: Buna

Model No.	Description	Lbs.
A0085-302	3" Thread-on	0.6
A0085-302S	3" Slip-on	0.6



Vents

A4103 Upward "V" Vent

Material

Body: Polyethylene
 Cap: Polyethylene
 Screws: Steel
 Screen: 40 Mesh Stainless Steel

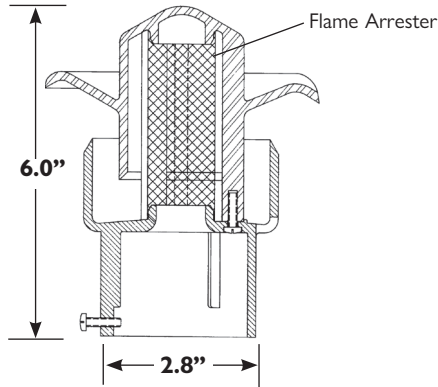

■ UL Listed MH10206

The Emco Wheaton A4103 Upward "V" Vent utilizes a straight-up "V" design to rapidly disperse vapors. Slip-on style vent attaches to the pipe with three screws for easy installation. Screen can be easily removed for cleaning. Designed in accordance with NFPA 30.

Model No.	Inlet	Material	Lbs.
A4103-002	2"	Polyethylene	0.7

A0785 Downward Mushroom Vent

Material

Body: Aluminum
 Screen: Stainless Steel

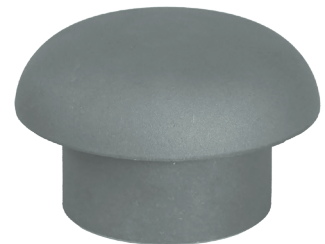
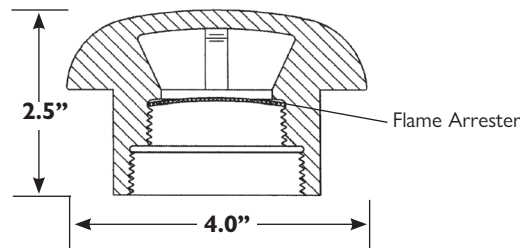

The Emco Wheaton A0785 Downward Mushroom Vent is designed for downward venting of storage tanks. The 30 mesh stainless steel screen can be easily removed for cleaning. The A0785 threads onto either 1.5 or 2.0 inch vent lines. Clear coated aluminum for corrosion-free service.

Model No.	Inlet	Material	Lbs.
A0785-001	1.5" & 2" Female	Aluminum	1.0
A0785-101	1.5" & 2" Female BSPT	Aluminum	1.0

Sealants

Z0838 Anti-Seize Joint Seal

Emco Wheaton Anti-Seize Joint Seal is recognized as one of the most versatile compounds available for its excellent sealing properties. Resistant to heat, cold and vibration.

Model No.	Size	Lbs.
Z0838-005	1/2 pint	1.3



Z0839 Super Duty Sealant

The Z0839 Urethane Super Duty Sealant is a general purpose sealant for fuel and water. Net contents 10.3 oz.

Model No.	Lbs.
Z0839-001	1.2



SPILL
CONTAINMENT

Spill Containment Selection Chart

Replaceable

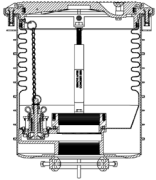
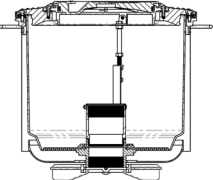
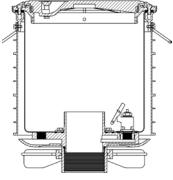
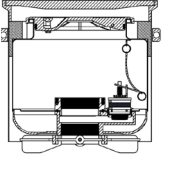
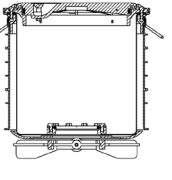
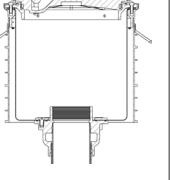
Single Wall		5 Gallon				15 Gallon
<p>Poly</p> <p>Screw On</p>  <p>Phase I EVR</p> <p>Drain: A1004EVR-316A</p> <p>No Drain: A1004EVR-317A</p> <p>Page #: 44, 90</p>	<p>Stainless Steel</p>				<p>Poly</p> <p>Screw On</p>  <p>Phase I EVR</p> <p>A1004EVR-216A</p> <p>45, 90</p>	
	<p>Screw On</p>  <p>Below Grade</p> <p>A1005-518AW</p> <p>40</p>	<p>Screw On</p>  <p>A1005-905D</p> <p>A1005-905</p> <p>42</p>	<p>Slip On</p>  <p>A1005-517AW</p> <p>40</p>	<p>Glass On</p>  <p>Remote Fill</p> <p>A1005-517AF</p> <p>46-47</p>		

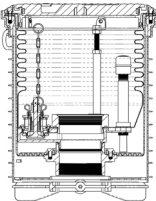
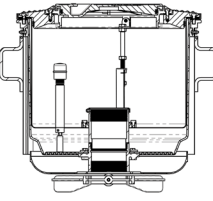
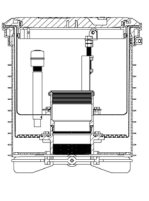
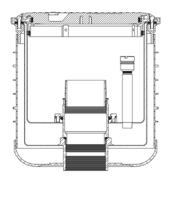
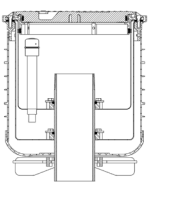
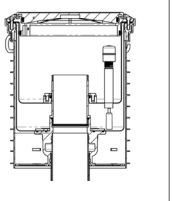
Double Wall		5 Gallon				15 Gallon
<p>Poly</p> <p>Screw On</p>  <p>Phase I EVR</p> <p>Drain: A1004EVR-316S</p> <p>No Drain: A1004EVR-317S</p> <p>Page #: 44, 90</p>	<p>Stainless Steel</p>				<p>Poly/SST</p> <p>Screw On</p>  <p>Phase I EVR</p> <p>A1004EVR-216SJ</p> <p>45 90</p>	
	<p>Poly/SST</p> <p>Screw On</p>  <p>Evolution Series</p> <p>Phase I EVR</p> <p>A1004EVR-317SS</p> <p>39, 90</p>	<p>Screw On</p>  <p>A1005-518GW</p> <p>40</p>	<p>Slip On</p>  <p>A1005-517GW</p> <p>40</p>	<p>Glass On</p>  <p>Remote Fill</p> <p>A1005-517SF</p> <p>46-47</p>		



Spill Containment Selection Chart

Replaceable

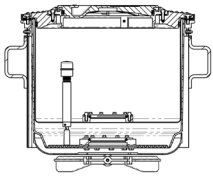
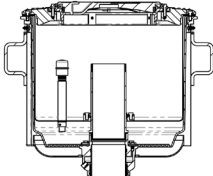
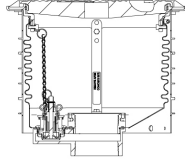
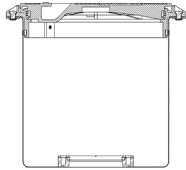
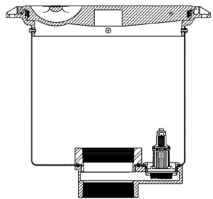
Non-Replaceable

Double Wall 15 Gallon		Single Wall 5 Gallon		
Stainless Steel		Poly	Stainless Steel	
<u>Slip On</u>	<u>Glass On</u>	<u>Thread On</u>	<u>Slip On</u> <u>Thread On</u>	
				
Drain:		Slimline		
No Drain:	A1005-616RD	A1004EVR-010	N/A	A1005-501T
Page #:	42	A1004EVR-011	A1005-517	A1005-501TN
		45, 90	43	43

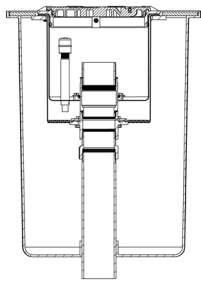
Retrofit

OPW 500/700		Competitor Buckets	
Stainless Steel Primary Poly Secondary		Stainless Steel	
<u>Thread On</u>	<u>Thread On</u>		
			Replaces
No Drain:	A1004EVR-317SS900		Emco 53
Page #:	56		Fairfield 54
			Pemco 54
			Franklin Fueling 54
			OPW 55
			Universal 57
			Pomeco 57
			Page #
			A1005-505C

Spill Containment

Replaceable

Stainless Steel/Poly

Evolution

The Evolution Series spill container features a corrosion free stainless steel primary container and is customizable for varied customer preferences.

- Rust-proof stainless steel primary containment vessel eliminates failures due to punctures or abuse
- Screw-on style incorporates female stainless fittings to receive EVR riser seal for fill applications or male stainless fittings for vapor applications
- **Never break concrete again** - easily repair or replace primary unit from grade without breaking concrete
- Grade level spill containment, 5 gallon capacity
- Installs on 16" center/center tank bung spacing
- EZ-Gage to monitor interstitial space at a glance

Select your desired features:

- Composite lid/stainless rim or cast iron lid/rim - water-resistant with built-in handle, exclusive triple wiper seal and vent valve. Meets AASHTO H20 wheel loading
- Lid and rim available powder coated to API color specifications
- Powder coated or stainless steel fitting
- For fill applications: Available with stainless steel riser seal, fill cap and brass or nickel plated swivel adapter.
For vapor applications: Available with stainless steel nipple, vapor cap and brass or nickel plated swivel adapter
- Drain

Contact Customer Service at 800-234-4394 for ordering information

Double Wall Stainless Steel Primary Poly Secondary

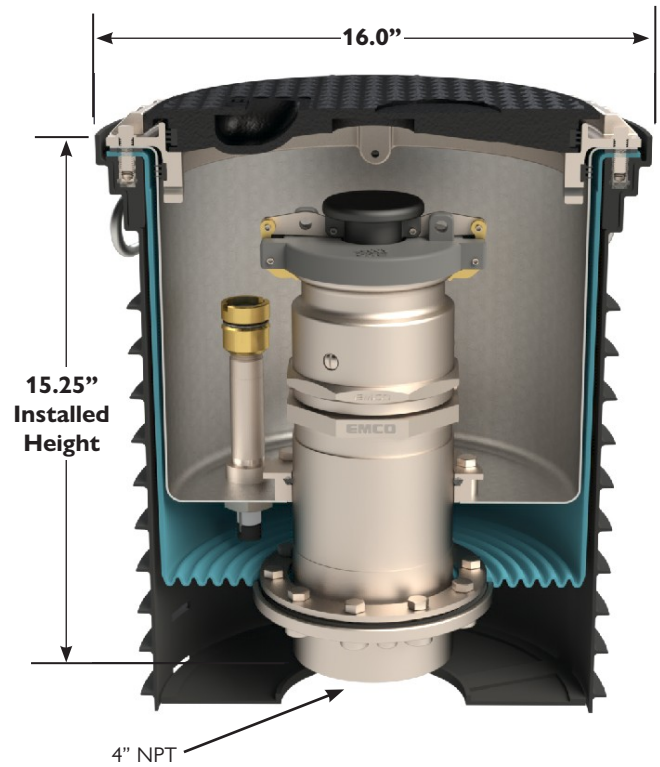

- CARB Phase I EVR Executive Order VR-105
ULC Listed MH21149
Florida DEP #EQ-741
NC DENR
MO DNR



Protective cover shields rim and lid from concrete slurry

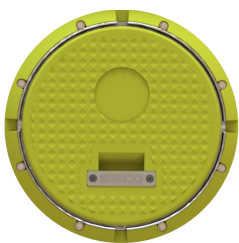

A1004-316LID-D
Ultra Low Sulfur Diesel
Yellow



A1004-316LID-R
Regular
White



A1004-316LID-V
Vapor
Orange

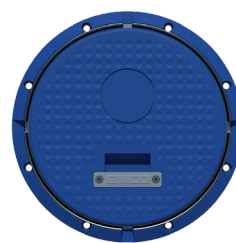

A1004-316LID-DEF
DEF
Blue



A1004-316LID-U
Ultra/Premium
Red

Spill Containment Stainless Steel/Poly

Replaceable

Evolution

Cast Iron Rim & Lid

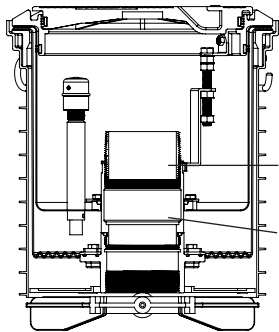

A7901-004CSS
SST Close Nipple

A7901-305F
Powder Coated Fitting



Powder Coated
Cast Iron Rim & Lid

Stainless Steel Rim/Composite Lid

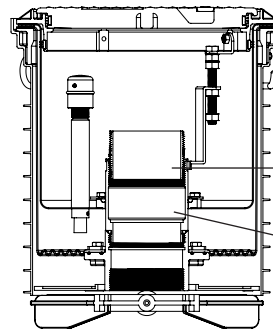

A7901-004CSS
SST Close Nipple

A7901-305FS
SST Fitting

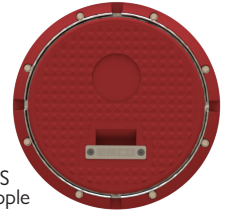

Powder Coated
Stainless Steel Rim
Composite Lid

Basic

Model No.	Rim/Lid	A0996 ID Tag
A1004EVR-317SS100	Black	----
A1004EVR-317SS101	White	----
A1004EVR-317SS102	Red	----
A1004EVR-317SS103	Yellow	----
A1004EVR-317SS104	Orange	Vapor
A1004EVR-317SS107	White	E0

Model No.	Rim/Lid	A0996 ID Tag
A1004EVR-317SS200	Not Coated	----
A1004EVR-317SS201	White	----
A1004EVR-317SS202	Red	----
A1004EVR-317SS203	Yellow	----
A1004EVR-317SS204	Orange	Vapor
A1004EVR-317SS206	Bronze	E85
A1004EVR-317SS207	White	E0
A1004EVR-317SS209	Blue	DEF

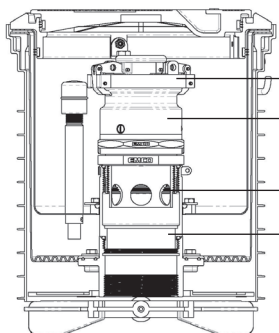

A0097-005 Cap

A0030-124S
Brass Swivel Adapter

494096 Riser Seal

A7901-305F
Powder Coated Fitting

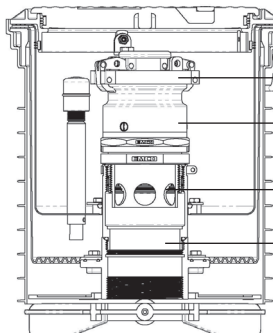

A0097-005 Cap

A0030-124S
Brass Swivel Adapter

494096 Riser Seal

A7901-305FS
SST Fitting

Fill Applications

Model No.	Rim/Lid	A0996 ID Tag
A1004EVR-317SS1B0	Black	----
A1004EVR-317SS1B1	White	----
A1004EVR-317SS1B2	Red	----
A1004EVR-317SS1B3	Yellow	----
A1004EVR-317SS1B7	White	E0

Model No.	Rim/Lid	A0996 ID Tag
A1004EVR-317SS2B0	Not Coated	----
A1004EVR-317SS2B1	White	----
A1004EVR-317SS2B2	Red	----
A1004EVR-317SS2B3	Yellow	----
A1004EVR-317SS2D6*	Bronze	E85
A1004EVR-317SS2B7	White	E0

*Includes nickel plated swivel adapter

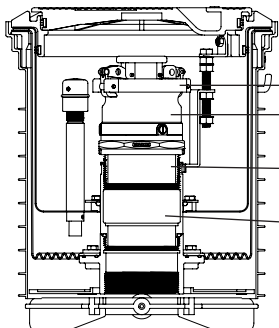

A0099-002 Cap

A0076-124S
Brass Swivel Adapter

A7901-004CSS
SST Close Nipple

A7901-305F Powder
Coated Fitting

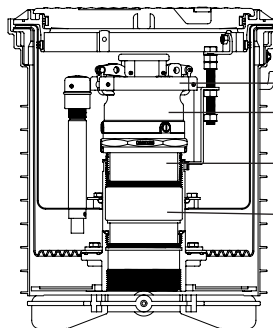

A0099-002 Cap

A0076-124S
Brass Swivel Adapter

A7901-004CSS
SST Close Nipple

A7901-305FS
SST Fitting

Vapor Applications

Model No.	Rim/ Lid	A0996 ID Tag
A1004EVR-317SS140	Black	----
A1004EVR-317SS244	Orange	Vapor

Model No.	Rim/ Lid	A0996 ID Tag
A1004EVR-317SS240	Not Coated	----
A1004EVR-317SS244	Orange	Vapor

Spill Containment

Replaceable

Stainless Steel

Evolution

**Double Wall
Stainless Steel Primary & Secondary**

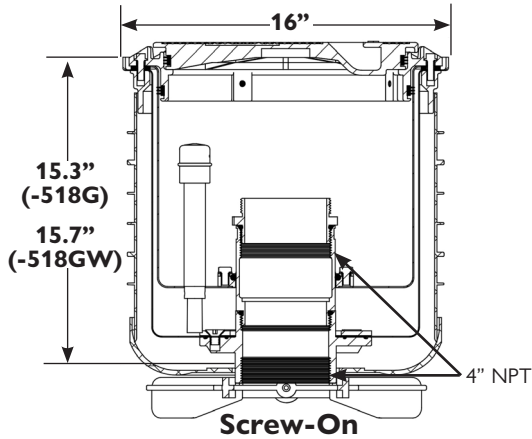

Model No.	Description
A1005-518G	DW stainless steel, cast iron secondary base, female 4" fitting, male coupling, gauge, cast iron rim & lid
A1005-518GW	DW all stainless steel, welded base, stainless steel female 4" fitting, male coupling, gauge, stainless steel rim/composite lid

**Single Wall
Stainless Steel**

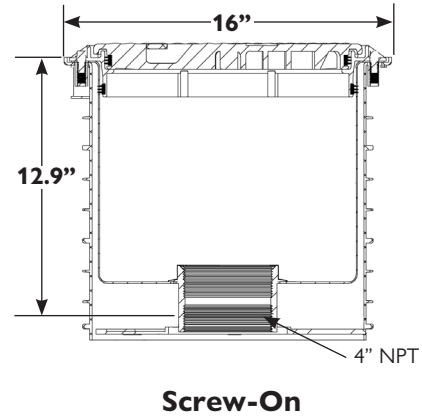

Model No.	Description
A1005-518A	SW stainless steel, welded base, cast iron rim & lid
A1005-518AW	SW all stainless steel, welded base, stainless steel rim/composite lid
A1005-518AW-DEF	SW all stainless steel, welded base, blue stainless steel rim/composite lid w/DEF ID tag

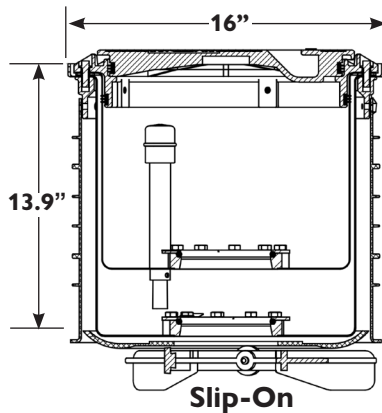

Model No.	Description
A1005-517G	DW stainless steel, gauge, cast iron rim & lid
A1005-517GW	DW all stainless steel, gauge, stainless steel rim/composite lid
A1005-517S-CM	DW stainless steel, sensor, cast iron rim & lid

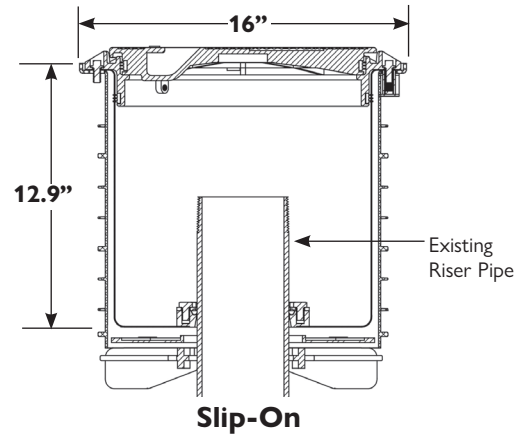

Model No.	Description
A1005-517A	SW stainless steel, cast iron rim & lid
A1005-517AW	SW all stainless steel, stainless steel rim & composite lid
A1005-517AW-DEF	SW all stainless steel, blue stainless steel rim/ composite lid w/DEF ID tag

Lid & Rim Options
Available powder coated to API color specifications



Cast Iron Rim & Lid

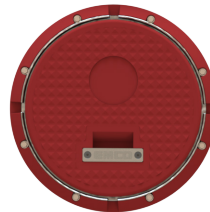

Stainless Steel Rim
Composite Lid

■ ULC Listed MH21149
Florida DEP #EQ-524

Evolution DEF

**Replaceable
Double Wall Stainless Steel**

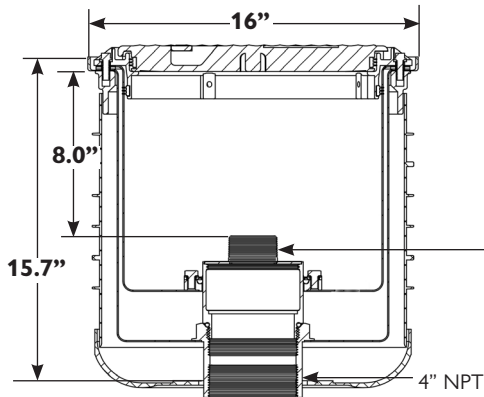

Screw-On

Model No.	Description
A1005-518GW2DEF	DW all stainless steel, welded base, stainless steel 4" female to 2" male NPT fitting, blue stainless steel rim/composite lid w/DEF ID tag
A1005-518GW2FDEF	DW all stainless steel, welded base, stainless steel 4" female to 2" female NPT fitting, blue stainless steel rim/composite lid w/DEF ID tag

**Replaceable
Single Wall Stainless Steel**

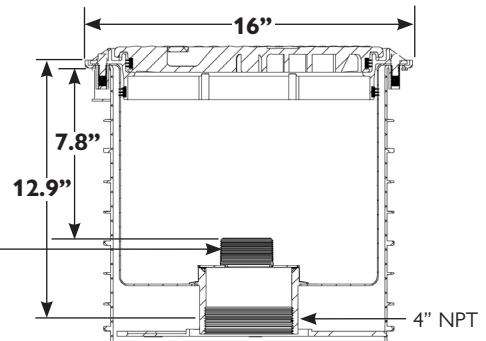

Screw-On

Model No.	Description
A1005-518AW2DEF	SW all stainless steel, welded base, blue stainless steel rim/composite lid w/DEF ID tag

■ ULC Listed MH21149
Florida DEP EQ-524

**Replaceable
Single Wall Stainless Steel**

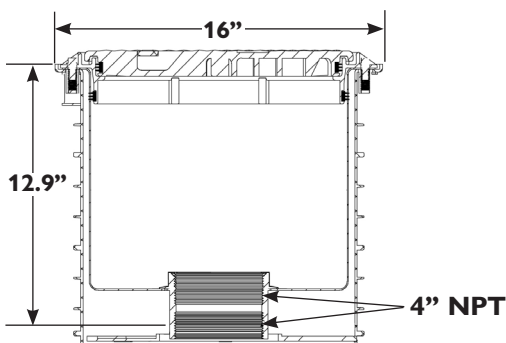

Screw-On

Model No.	Description
A1005-518AW-DEF	SW all stainless steel, welded base, blue stainless steel rim/composite lid w/DEF ID tag

**Replaceable
Single Wall Stainless Steel**

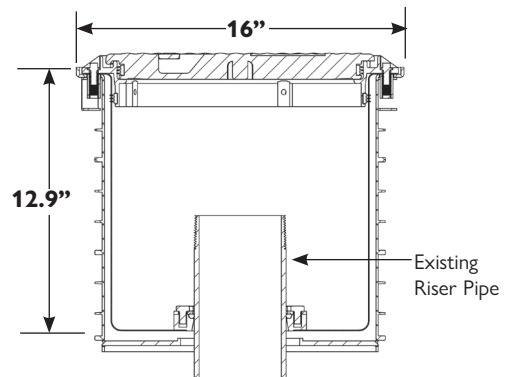

Slip-On

Model No.	Description
A1005-517AW-DEF	SW all stainless steel, blue stainless steel rim/composite lid w/DEF ID tag

Spill Containment

Special Applications

Stainless Steel/Poly

Evolution

Replaceable
Stainless Steel

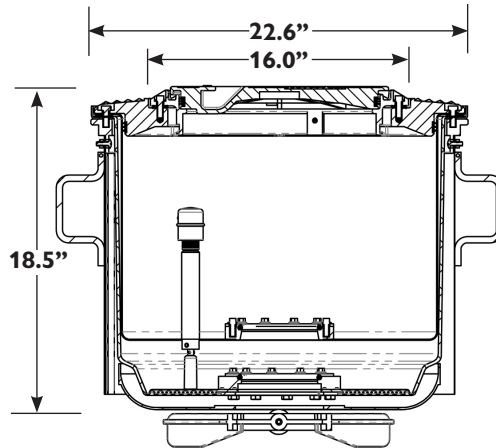
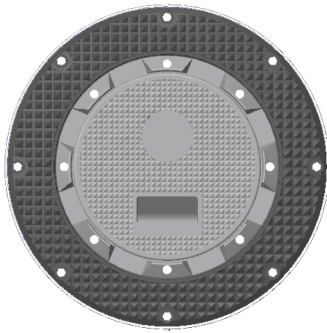

**15 Gallon, Double Wall
SST Primary, Poly Secondary**

Model No.	Description
A1005-616RD	SST Primary/Poly Secondary, no drain, 16" cast iron rim & lid, 22" to 16" cast iron rim adapter, gauge, riser lock

Replaceable
Below Grade Stainless Steel



Replaceable from above ground

Grade level lid also available in cast iron

Optional locking mechanism for below grade lid

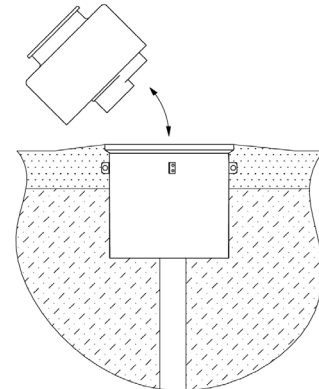

■ ULC Listed MH21149

**Screw-On
5 Gallon**

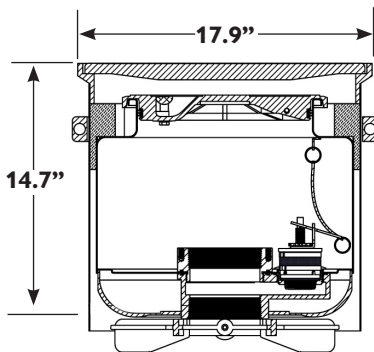

**Screw-On
15 Gallon**

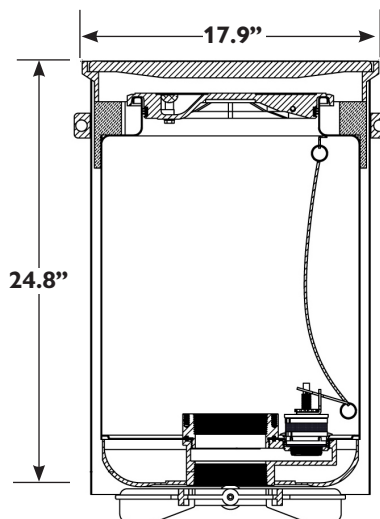

Model No.	Description
A1005-905	Composite grade level lid, cast iron below grade lid, drain plug
A1005-905D	Composite grade level lid, cast iron below grade lid, drain
A1005-915	Composite grade level lid, cast iron below grade lid, drain plug
A1005-915D	Composite grade level lid, cast iron below grade lid, drain

Spill Containment

Special Applications

Stainless Steel

Replaceable Stainless Steel

Non-Replaceable Stainless Steel

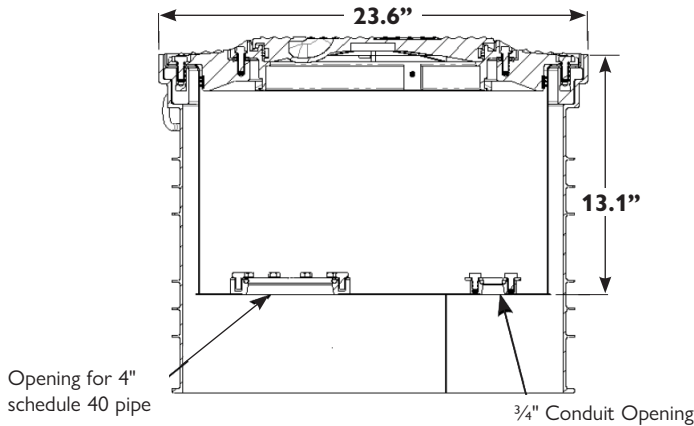

Slip-On Offset Tank Monitor

Model No.	Description
A1005-015TMFA	15 Gallon Single Wall Tank Monitor, Slip On, Replaceable, Powdercoated Cast Iron Lid and Rim, No Drain, Stainless Steel, (Offset 4" Pipe Entry/Tank Monitor, 3/4" Conduit Entry)

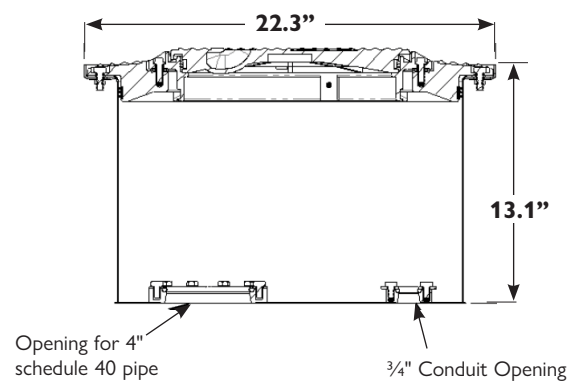

Slip-On Offset Tank Monitor

Model No.	Description
A1005-015TMFA-N	15 Gallon Single Wall Tank Monitor, Slip On, Non-replaceable, Powdercoated Cast Iron Lid and Rim, No Drain, Stainless Steel, (Offset 4" Pipe Entry/Tank Monitor, 3/4" Conduit Entry)

Non-Replaceable Stainless Steel

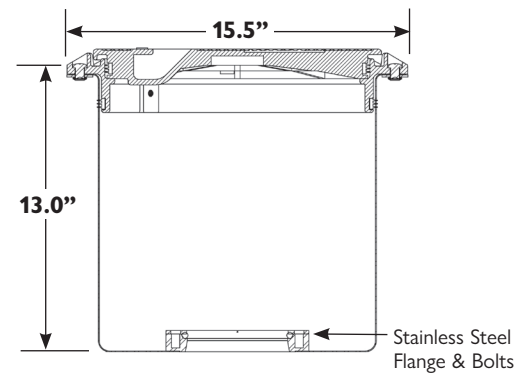

Slip-On

Model No.	Description
A1005-517	Cast iron lid, 4" riser pipe
A1005-517-3	Cast iron lid, 3" riser pipe
A1005-517-C	Composite lid, 4" riser pipe

Spill Containment

Replaceable

Poly (HDPE)

The **A1004EVR-316 Series spill container** is Phase I EVR Certified under Executive Order VR-105.

- **Never break concrete again** - easily repair or replace primary and secondary units from grade without breaking concrete
- Grade level spill containment, 5 gallon capacity
- Installs on 16" center/center tank bung spacing
- Single wall or double wall - screw-on style
- HDPE bellows
- Powder coated, water-resistant cast iron or composite lid with built-in handle, exclusive triple wiper seal and vent valve; meets AASHTO H20 wheel loading
- Lid and rim available powder coated to API color specifications
- EZ-Gage to monitor interstitial space at a glance
- (double wall versions)
- 4 inch NPT or BSPT thread

- CARB Phase I EVR Executive Order VR-105
- ULC Listed MH21149
- Florida DEP #EQ-741 (5 gal); #EQ-695 (15 gal)
- MO DNR, NC DENR

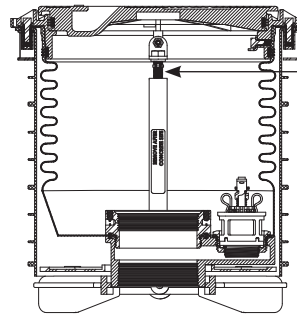

Adjustment screws allow change in elevation $\pm 1\frac{1}{2}$ " (5 gallon models)

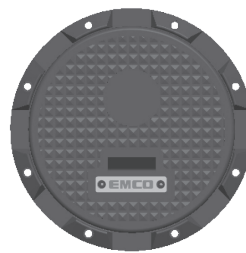

Composite Lid
Ductile Iron Rim



Ductile Iron Lid
Ductile Iron Rim

Double Wall Poly

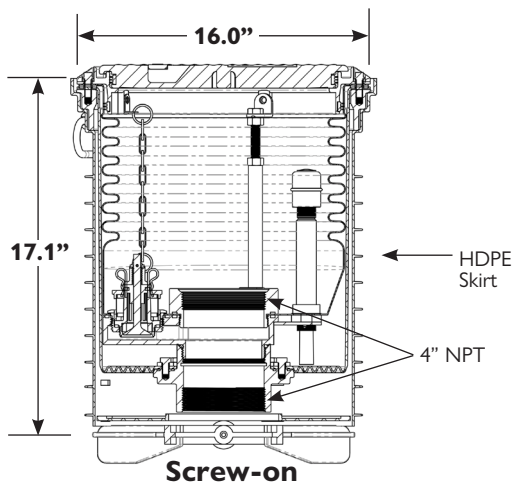

Single Wall Poly

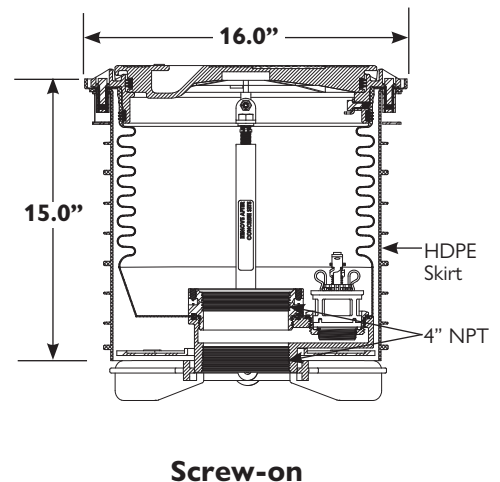

Model No.	Description
A1004EVR-316S	DW poly, drain
A1004EVR-316S-CM	DW poly, drain, sensor
A1004EVR-317S	DW poly, no drain
A1004EVR-317S-CM	DW poly, no drain, sensor
A1004EVR-317S7	DW poly, no drain, stainless steel rim

Model No.	Description
A1004EVR-316A	SW poly, drain
A1004EVR-317A	SW poly, drain plug
A1004EVR-317A7	SW poly, drain plug, stainless steel rim

Spill Containment Stainless Steel/Poly

Replaceable

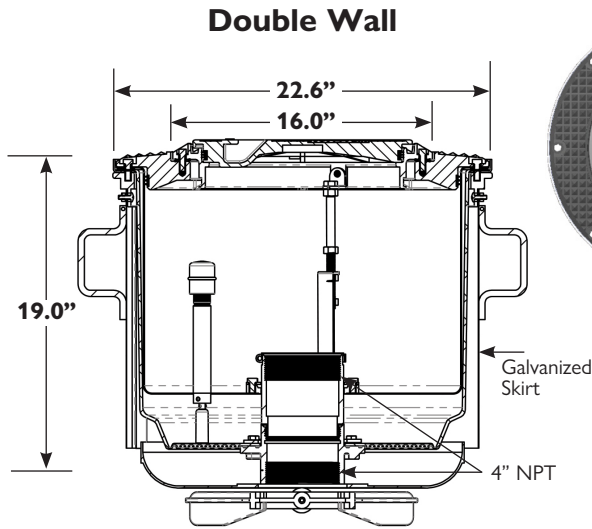

**Screw-on
15 Gallon**

Model No.	Description
A1004EVR-216SJ	DW SST primary, poly secondary, no drain, gauge
A1004EVR-216SJ-CM	DW SST primary, poly secondary, no drain, sensor

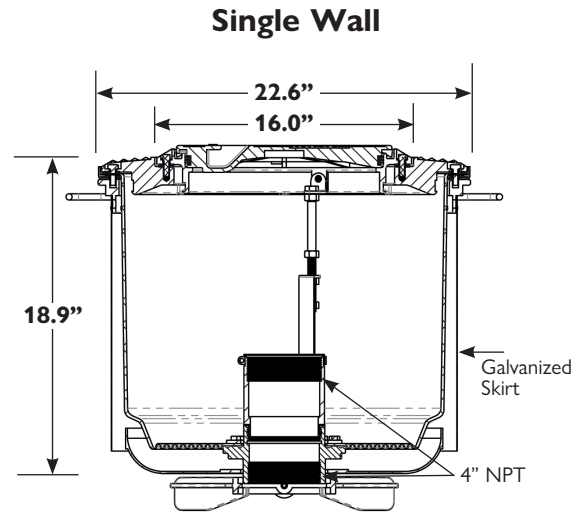
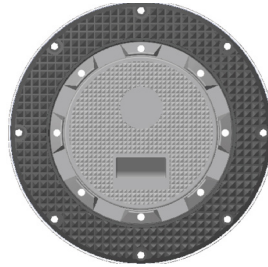

Single Wall

**Screw-on
15 Gallon**

Model No.	Description
A1004EVR-216A	SW poly, no drain

Non-Replaceable Single Wall Poly (HDPE)

- Grade level spill containment, 5 gallon capacity
- Heavy duty, snow plow resistant cast iron, powder coated plow rim
- HDPE bellows and skirt
- 4 inch NPT or BSPT thread
- Powder coated, water-resistant cast iron or composite lid with built-in handle, exclusive triple wiper seal and vent valve. Meets AASHTO H20 wheel loading

Slimline

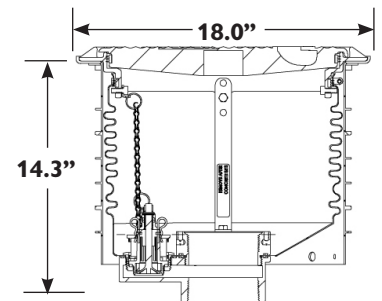

Screw-on



- CARB Phase I EVR Executive Order VR-105
- ULC Listed MH21149
- Florida DEP #EQ-524

Model No.	Description
* A1004-010	Cast iron lid, drain
A1004-011	Cast iron lid, drain plug
A1004-012	Cast iron lid, drain, BSPT
* A1004EVR-010	Cast iron lid, drain, EVR
A1004EVR-011	Cast iron lid, drain plug, EVR
A1004EVR-012	Cast iron lid, drain, BSPT, EVR

*Most common variant

Spill Containment

Special Applications

Remote Fill

- Creates true double wall containment from spill bucket to the piping run
- Assembly comes complete with stub, ready for installation into the elbow and clamshell 3" or 4" double wall Dualoy® 3000/LCX OR 3" or 4" single wall Red Thread®
- Water-resistant cast iron lid with built-in handle, exclusive triple wiper seal and vent valve. Meets H20 load rating
- Includes EZ-Gage for instant monitoring of interstitial space



■ ULC Listed MH21149

Available options:

- Composite lid and stainless steel rim
- Lid and rim available powder coated to API color specifications (see below)
- Drain
- Electronic sensors
- 3" or 4" pipe
- 5 or 15 gallon capacity

Painted Lids - API Product Codes

Add to the end of the variant number:

- D Yellow ULSD
- R White Regular
- U Red Premium
- V Orange Vapor
- E Bronze E85

Contact Customer Service at
800-234-4394 for additional colors

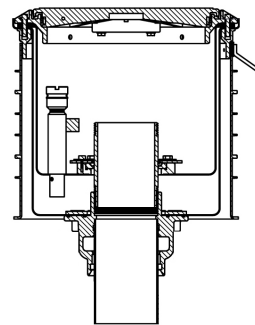

5 Gallon

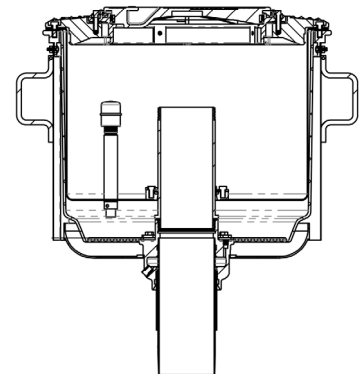

15 Gallon

Model No.	Spill Containment Description	Stub Out Description
A1005-517SF	DW stainless steel, no drain, gauge	4" DW Dualoy® 3000/LCX
A1005-517SF3	DW stainless steel, no drain, gauge	3" DW Dualoy® 3000/LCX
A1005-517SF3SW	DW stainless steel, no drain, gauge	3" SW Red Thread®
A1005-616SF3SWW	DW SST primary/poly secondary, no drain, 15 gal Vapor Cap & Swivel Adapter	3" SW Red Thread®
A1005-616SF3X	DW SST primary/poly secondary, no drain, 15 gal Fill Cap & Swivel Adapter	3" DW Dualoy® 3000/LCX
A1005-616SF4	DW SST primary/poly secondary, no drain, 15 gal	4" DW Dualoy® 3000/LCX

Special Applications

Remote Fill

Remote fill is used when the fill point is not directly over the underground storage tank. A typical remote fill installation includes a single wall spill container installed directly over the UST for tank gauging purposes. The Overfill Prevention Valve is installed into this spill container with a remote fill cage mounted into the upper tube; this cage aligns with and seals against the tee connected to the fuel drop point forcing fuel through the OPV. Build out your system with individual parts or order the A1100-056RF Remote Fill OPV Kit which includes everything you need to get started.

Part Number	Description
A1100-056RF	Remote Fill OPV Kit, 10' Tank
L A0097-005	Fill Adapter Cap
L A0030-024	Fill Adapter, Brass
L A0479-001	Auxiliary Tank Gauge Stick Port
L A0079-444SS	Remote Fill Tee, Stainless Steel
L 493436	Remote Fill Cage
L A1100EVR-056	Overfill Prevention Valve, 7' Bury/10' Tank Dia.

The spill container, riser seal, and riser pipes are not included in this kit.

Need To Know

- » This remote fill system is vapor tight and EPA 40 Part 63 compliant. This system is not CARB EVR approved; for the CARB EVR approved remote fill solution, see pg. 23.
- » This system requires the use of Emco A7901 4.1" controlled ID pipe nipples or equivalent. Schedule 40 seam welded riser pipe will not seal with this configuration.

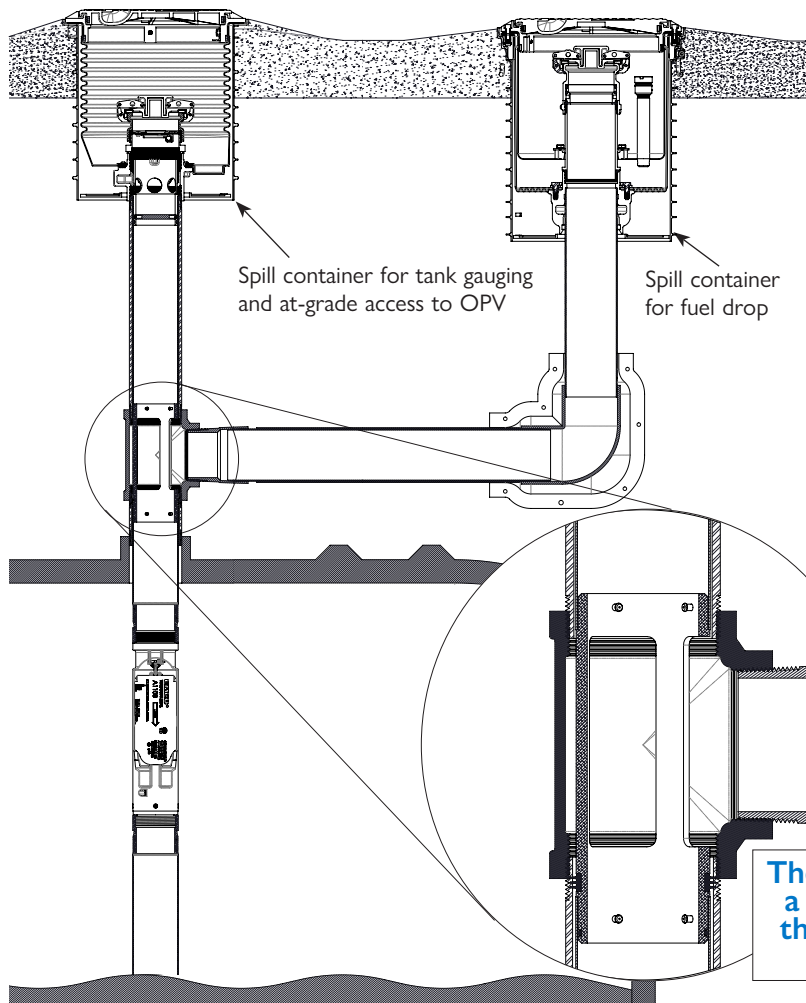

Single Wall Spill Container
A1004EVR-317A
Additional variants available

Fill Cap
A0097-005

Fill Adapter
A0030-024

Tank Gauge Port
A0479-001

Riser Seal
494096

Emco Riser Pipe
A7901-XXX
Custom sizes available
See pg. 60 for details

Remote Fill Tee SST
A0079-444SS

Remote Fill Cage
493436EPA

Emco Riser Pipe
A7901-XXX
Custom sizes available
See pg. 60 for details

Overfill Prevention Valve
A1100EVR-056
Additional variants available

The triple wiper seal forms a vapor tight seal against the riser pipe forcing fuel through the OPV.

Spill Containment

Special Applications

Remote Fill Vault

Above Ground Remote Fill Containment Sump, DW, 1 Fill

Double wall spill containment

All stainless steel construction

Keeps your spill containers above ground

Available with 2" or 3" stainless steel piping for attachment to fill adapter and piping- NPT threads for DEF

Adjustable leg height (from 2 ft. to 4 ft.) positions the spill container at grade level for installation of piping and backfilling

Removable stainless steel skirt for ease of installation

Hinged lid for easy access

Available options:
Lockable lid

A1005-761-DEF2
Above Ground
Remote Fill
Containment Sump
1 Fill, 2" Piping



Front View

Model No.	Description
A1005-761-DEF2	Above Ground Remote Fill Containment Sump, 1 Fill, 2" Piping
A1005-761-DEF3	Above Ground Remote Fill Containment Sump, 1 Fill, 3" Piping

Custom configurations are available upon request

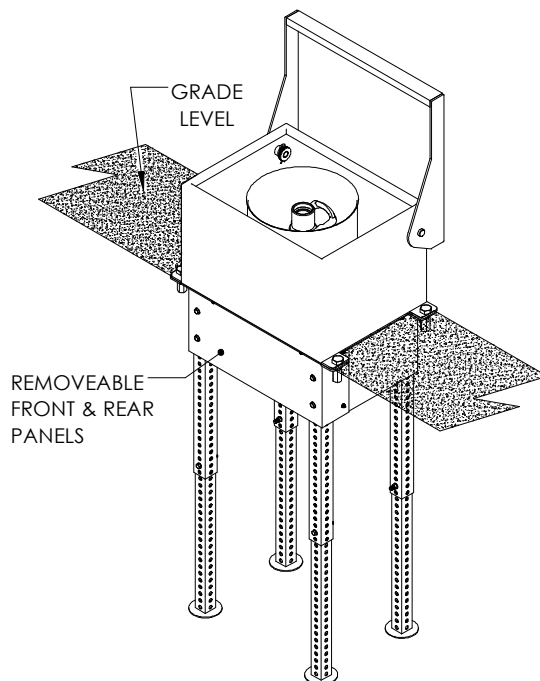

Top View

Above Ground Remote Fill Containment Sump, DW, 3 Fill + Vapor

- Double wall spill containment
- All stainless steel construction
- Keeps your spill containers above ground
- Adjustable leg height (from 2 ft. to 4 ft.) positions the spill container at grade level for installation of piping and backfilling
- Removable stainless steel skirt for ease of installation
- Hinged lid for easy access
- Available options:
 - Lockable lid
 - Custom sizes available for 2 to 5 containment sumps



A1005-764-2001
Remote Fill Vault
3 Fill + Vapor

■ UL 2583 Approved (MH46838)

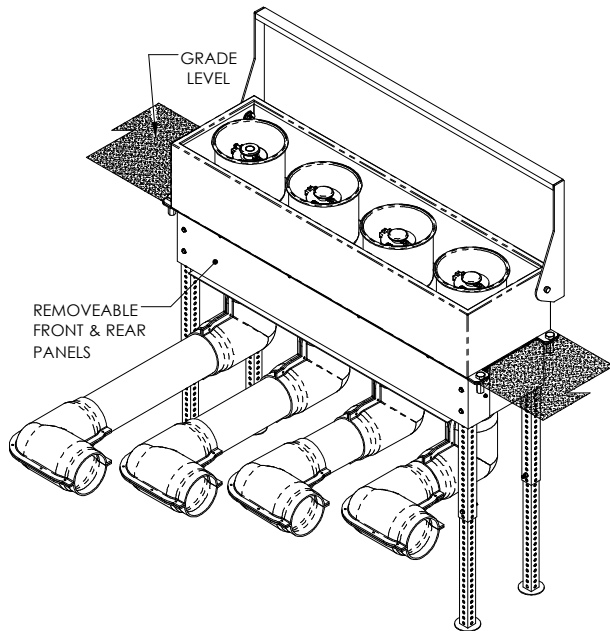

Closed View

Spill Containment

Multi-Port Phase I EVR

The **A1004EVR Multi-Port Spill Containers** are Phase I EVR approved and include the following features:

- 42-inch steel diamond plate lid with 16-inch tank bung spacing
- *Optional diamond plate lid in light weight aluminum*
- 6 cam-locks and dual lid handles for easy lock-down and removal
- 8-inch observation port w/ water-tight seals
- All mounting bolts non-corrosive stainless steel
- Manhole rim channel w/ D-seal for water tightness integrity between lid and rim
- Manhole available w/ 12-inch or 18-inch galvanized skirt
- Nominal spill container capacity of 5 US gallons
- Cast iron spill container base w/4-inch NPT thread connection
Requires no face seal adapter
- Powder coated, heavy duty, cast iron lid and ductile iron plow ring, exceeds DOT H-20 loading
Optional lid in composite material
- Lid w/ triple wiper seal
- HDPE primary spill container bellows
- Drain valve w/ filter or plug option
- Compatible with most water shrouds and boot kits

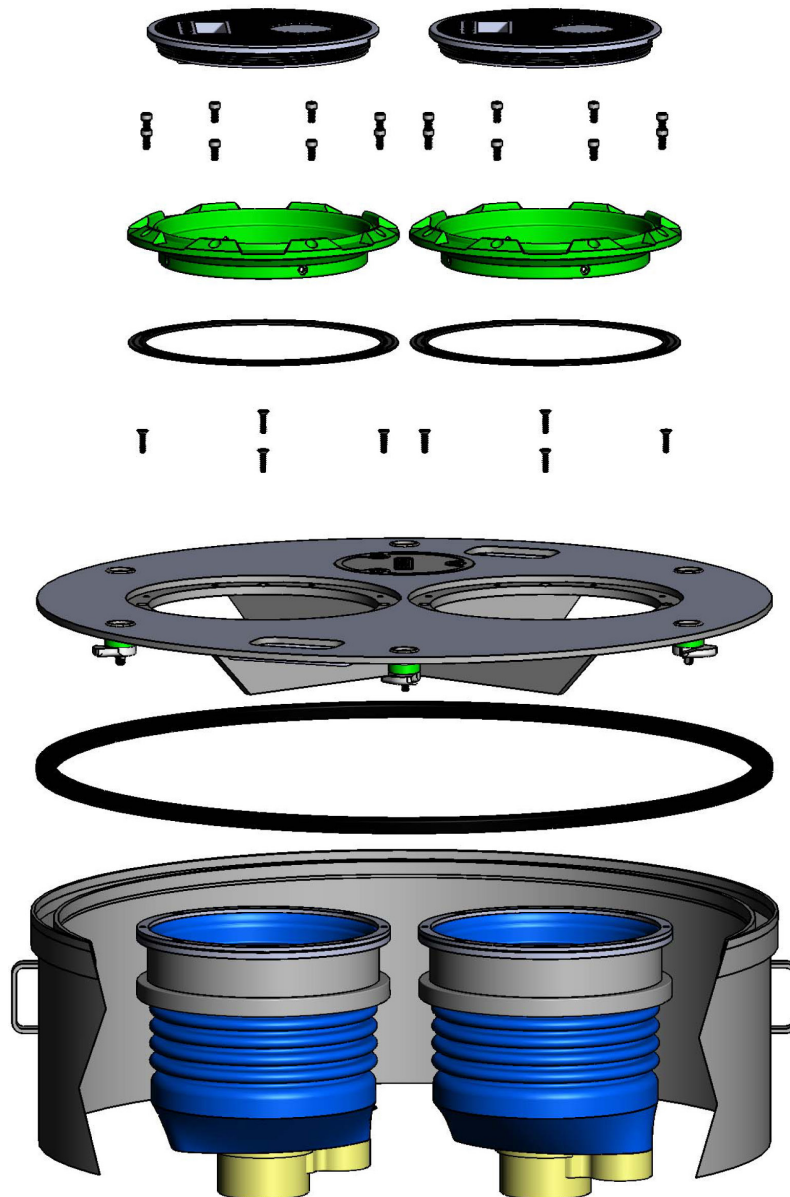

■ CARB Phase I EVR Executive Order VR-105

Model No.	Description	Spill Container #1	Drain Type	Spill Container #2	Drain Type
A1004EVR-2421D1A	42" Multi-Port MH, 8" Observation Port 12" Skirt, Gasoline	SW, 5 gal	Drain Valve	SW, 5 gal	No Drain
A1004EVR-242101A	42" Multi-Port MH, 8" Observation Port 12" Skirt, Gasoline	SW, 5 gal	No Drain	SW, 5 gal	No Drain
A1004EVR-2421D0A	42" Multi-Port MH, 8" Observation Port 12" Skirt, Diesel	SW, 5 gal	Drain Valve	None	N/A
A1004EVR-242100A	42" Multi-Port MH, 8" Observation Port 12" Skirt, Diesel	SW, 5 gal	No Drain	None	N/A

Custom configurations are available upon request

Spill Containment Multi-Port General Purpose

- 36-inch steel diamond plate lid with 16-inch tank bung spacing
- *Optional diamond plate lid in light weight aluminum*
- 6 cam-locks and dual lid handles for easy lock-down and removal
- 8-inch observation port w/ water-tight seals
- All mounting bolts non-corrosive stainless steel
- Manhole rim channel w/ D-seal for water tightness integrity between lid and rim
- Manhole available w/ 12-inch or 18-inch galvanized skirt
- Nominal spill container capacity of 5 US gallons
- Stainless steel spill container w/4-inch slip-on connection
- Powder coated, heavy duty, cast iron lid and ductile iron plow ring, exceeds DOT H-20 loading
Optional lid in composite material
- Lid w/ triple wiper seal
- Compatible with most water shrouds
- Includes shroud seal

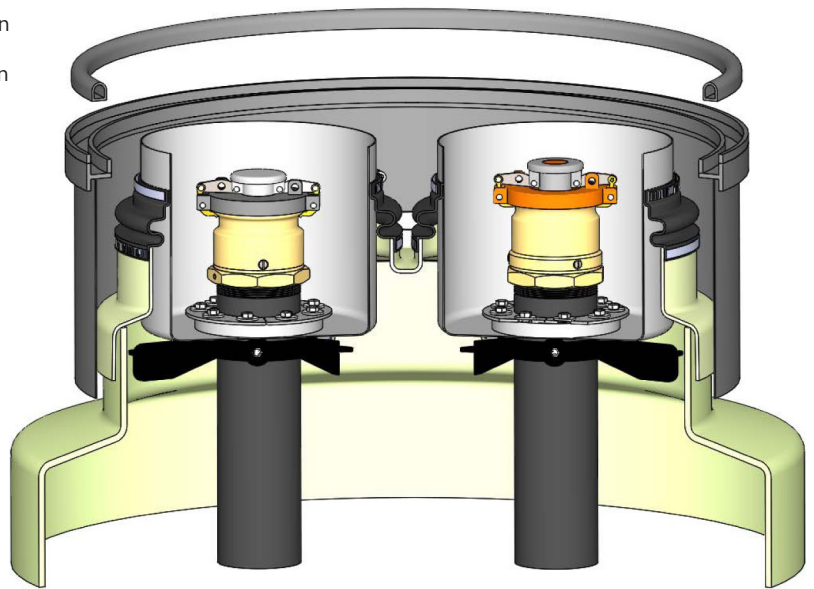
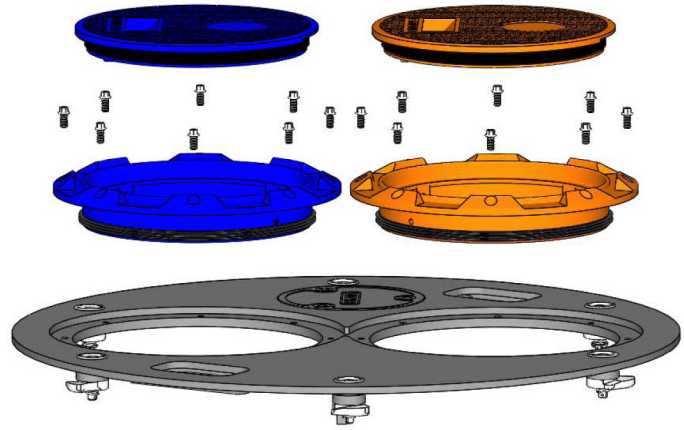

A1008-036B5

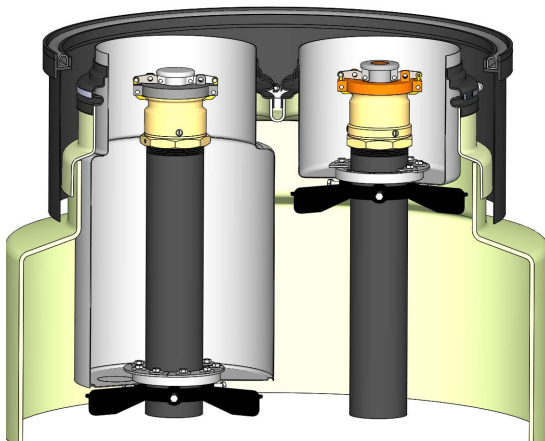

A1008-036B1

Model No.	Description	Spill Container #1	Drain Type	Spill Container #2	Drain Type
A1008-036B1	36" Multi-Port MH, 12" Skirt	SW, SST, 15 gal Fill Cap & Adapter	No Drain	SW, SST, 5 gal Vapor Cap & Adapter	No Drain
A1008-036B5	36" Multi-Port MH, 12" Skirt	SW, SST, 5 gal Fill Cap & Adapter	No Drain	SW, SST, 5 gal Vapor Cap & Adapter	No Drain

Custom configurations are available upon request

Spill Containment

Retrofit

Stainless Steel

Convert your obsolete poly bucket to state-of-the-art stainless steel - no excavation required



Before



After

- The containment vessel completely isolates the existing manhole; the lid seals inside the stainless steel vessel
- Water-resistant cast iron lid with built-in handle and exclusive triple wiper seal, meets AASHTO H20 wheel loading
- Models available for virtually all common competitors' buckets - Emco will provide custom designs for rare or unique applications. Models can be customized to accommodate specific height requirements. Contact our Customer Service Department (800-234-4394) for ordering information. Data sheets available on our website (www.emcoretail.com).
- US Patents 8,425,145 B2 and 8,425,145 B

- ULC Listed MH21149
- Florida DEP EQ-753; EQ-764R (Double Wall)
- Kentucky DEP
- Missouri DNR
- North Carolina DENR
- Tennessee Dept. of Environment & Conservation
- PEMEX PXR-SC-GVES-SAFP-SPTF-80-2013



Cast Iron Cover with Triple Wiper Seal



Stainless Steel Containment Vessel
Stainless Steel Bolts
Flange
O-ring Seal



Double wall variants include an EZ-Gage

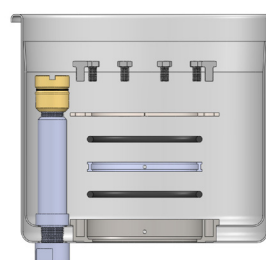

For drain options, contact our Customer Service Department (800-234-4394)

Spill Containment

Emco Stainless Steel

Retrofit

Emco A1003



Rim 15.75"; Lid 15.75"

Emco A1004-010 (Slimline)

Emco A1005-001



Rim 17.6"; Lid 15.3"

Emco A1005-501



Rim 16"; Lid 13.2"

Emco A1004-210 Series

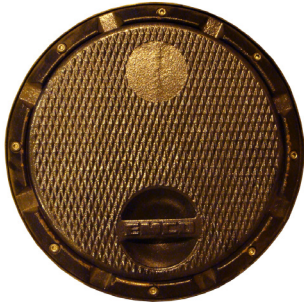

Rim 17.6"; Lid 15.3"

Emco A1004-316 Series



Rim 16"; Lid 13.2"



Model No.	Repairs	Lbs.
A1005-505CEW1	A1004-211A Single Wall	47.0
A1005-505CEW1DR	A1004-210A Single Wall, Includes Drain	48.9
A1005-505CEW1G	A1004-211S Double Wall, Includes Primary Unit & EZ-Gage	48.2
A1005-505CEW1GDR	A1004-210S Double Wall, Includes Primary Unit, Drain & EZ-Gage	50.1
A1005-505CEW2	A1004-317A Single Wall	36.3
A1005-505CEW2DR	A1004-316A Single Wall, Includes Drain	39.4
A1005-505CEW2G	A1004-317S Double Wall, Includes Primary Unit & EZ-Gage	37.5
A1005-505CEW2GDR	A1004-316S Double Wall, Includes Primary & Secondary Units, Drain & EZ-Gage	39.4
A1005-505CEW2GDV	A1004-317S Double Wall, Includes Primary & Secondary Units & EZ-Gage	37.5
A1005-505CEW3	Emco A1004-010 Series	26.0
A1005-505CEW3DR	Emco A1004-010 Series, Includes Drain	26.0
A1005-505CEW3A	Emco A1005-001	26.0
A1005-505CEW4	Emco A1003 Series	28.0
A1005-505CEW4DR	Emco A1003 Series, Includes Drain	28.3
A1005-505CEW6	Emco A1005-501	26.0
494697S	Drain Plug Kit, A1004-210, -316 Series (Aluminum Drains)	
495202	Drain Plug Kit, A1004-010, -210, -316 Series (Plastic Drains)	

Inserts without drains will require purchase of the proper drain plug kit for the existing spill container.

There are two styles of A1004-210. Double wall versions require either an NPT or NPSM adapter; both adapters are included with each kit. You may return the unused adapter to Emco for credit. Single wall versions include an A0031-725 Riser Extension (-725P for drain versions). Adapters are included with the A1004-316 kits for nominal installation heights.

For stretched or compressed bellows applications, additional adapter lengths are available. Contact Customer Service at 800-234-4394.

Spill Containment

Retrofit

Fairfield, Pemco Stainless Steel

Fairfield SCM-5



Rim 15.5"; Lid 13.5"

Model No.	Repairs	Lbs.
A1005-505CF5	Fairfield SCM-5	29.9

Pemco 112



Rim 15.75"; Lid 13.13"

Model No.	Repairs	Lbs.
A1005-505CPEM	Pemco 112	24.0

Retrofit

Franklin Fueling Stainless Steel

EBW 702*, 703, 705, 715, 725



Rim 17.25"; Lid 14"

*EBW 702 is slip-on

Franklin Defender™ 705545, 705555



Rim 16"; Lid 12"

EBW 715, 725 Below Grade

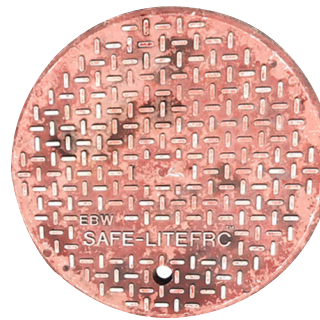

Rim 19.75"; Lid 19"

Phil-Tite 400



Rim 16"; Lid 14"

Model No.	Repairs	Lbs.
A1005-505CE	EBW 702,703,705	26.0
A1005-505CE770	EBW 702,703,705 Short	24.9
A1005-505CE15	EBW 715,725 15 Gallon	30.0
A1005-505CEBG	EBW 702,705, 715 Below Grade	25.6
A1005-505CFD	EBW 705555	
A1005-505CFDSW	EBW 705545	
A1005-505CFI	Phil-Tite 400	30.0
A1005-505DPEB	Drain Plug Kit for EBW 705,715	

Inserts without drains will require purchase of the proper drain plug kit for the existing spill container.

Defender Series™ is a trademark of Franklin Electric Co., Inc.

Spill Containment

OPW Stainless Steel

Retrofit

OPW 1-2100, 1-2105



Rim 16.0"; Lid 13.75"

**OPW 1SC-2100
OPW 1SC-2105
Offset**



Rim 15.75"; Lid 12.5"

OPW 84D



Rim 16.0"; Lid 13.75"

**OPW 101BG
Below Grade**



Rim 20.5"; Lid 20.0"

**OPW Edge™
3112, 3101**



Rim 16.6"; Lid 13.75"

OPW 4000

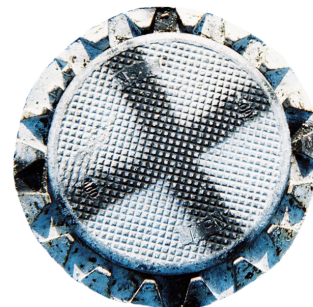

Rim 16.375"; Lid 13.125"

Model No.	Repairs OPW	Lbs.
A1005-505C	1-2100 Series	31.0
A1005-505CDR	1-2100; Includes Drain	30.5
A1005-505CS	1-2100 Short	27.0
A1005-505CZ	1-2100 Crooked Riser	30.0
A1005-505CZDR	" "; Includes Drain	30.0
A1005-505C5	1-2105 Offset	26.0
A1005-505CC	1SC-2100 Series	24.0
A1005-505CC5	1SC-2105 Offset	23.0
A1005-505C4*	4000	24.0
A1005-505CA	84D	41.0
A1005-505CBG	101BG	39.0
A1005-505CPWE	1C-3112P Series, Double Wall Edge	
A1005-505CPWESW	1C-3101P Series, Single Wall Edge	
A1005-505DP	Drain Plug Kit, 1-2100/1-2105	
A1005-505DPE	Drain Plug Kit w/Epoxy	

*Not available with a drain option.

Inserts without drains will require purchase of the proper drain plug kit for the existing spill container.

Edge™ is a trademark of Delaware Capital Formation, Inc.



The 1-2100 and 1-2105 series are identified with "1-2100 Series" or "1C Series" printed on the lid. You must determine if the spill containment has a 1" offset and a rubber boot (above photo). This indicates that it is a 1-2105 (slip-on) series, and will require a different retrofit kit than the 1-2100 series. Refer to table at left.

Spill Containment

Retrofit

OPW 500/700

No excavation required - use existing riser pipe

Eliminates all OPW primary and secondary containers

Diamond plate steel lid bolts to existing OPW rim; optional 24" gasket available for sealing the diamond plate

Includes: 24" diamond plate, ductile iron rim, cast iron lid with triple wiper seal, thread-on polyethylene secondary, 5 gallon stainless steel (or poly), primary with EZ-Gage; stainless steel fitting

Full Emco Wheaton warranty

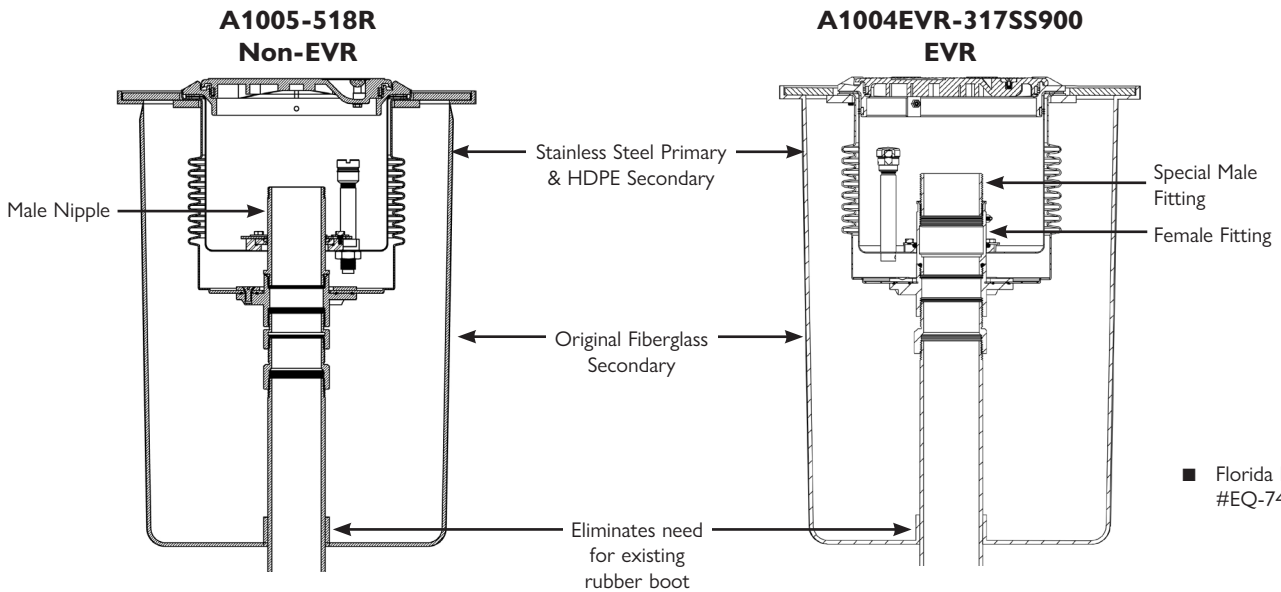

A0081-001R Lid Wrench
Special assembly tool facilitates one hour installation

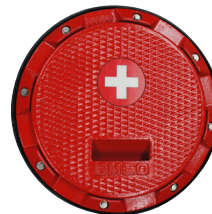

Lid and rim available powder coated to API color specifications

Model Number	Description	Lbs.
A1004EVR-317SS800	5 gal primary stainless steel slip-on, secondary poly thread-on, no drain, rim seal	114
A1004EVR-317SS900	5 gal primary stainless steel slip-on, secondary poly thread-on, no drain	113
A1004EVR-317SM900	5 gal primary stainless steel slip-on, secondary poly thread-on, no drain, sensor	115
A1005-518R	5 gal primary stainless steel slip-on, secondary poly thread-on, male nipple, no drain	116
A1005-518RS	5 gal primary stainless steel slip-on, secondary poly thread-on, male nipple, no drain, rim seal	117
A1005-518R-CM	5 gal primary stainless steel slip-on, secondary poly thread-on, male nipple, no drain, sensor	118

Accessories

A0081-001R Wrench for 24" diamond plate
571964 Seal for diamond plate

Spill Containment Pomeco Stainless Steel

Retrofit

Pomeco 111KP, 111KB



Rim 15.5"; Lid 12.25"

Pomeco 211



Rim 21"; Lid 17.25"

Model No.	Repairs	Lbs.
A1005-505CP1	Pomeco 111KP,111KB	25.0
A1005-505CP	Pomeco 211	42.3

Retrofit

Universal Stainless Steel

Universal 69RT, 71CD



69RT, 71CD
Rim 15"; Lid 12.75"

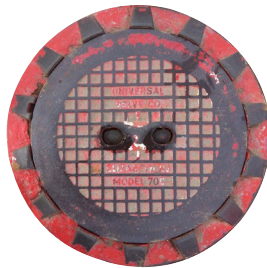

69RT, 71CD; 70C-DW
Rim 15.5"; 12.5" Lid

Universal 70C, 71CD



70C; 71CD
Rim 15.75"; Lid 15"

Model No.	Repairs	Lbs.
A1005-505CU	Universal 69RT, 71CD; Thread-on	26.0
A1005-505CU70	Universal 70C; Slip-on	29.0
A1005-505DPU	Drain Plug Kit, 69RT, 71CD	0.4

Inserts without drains will require purchase of the proper drain plug kit for the existing spill container.

Spill Containment

Retrofit

Accessories

A7901 Adapter

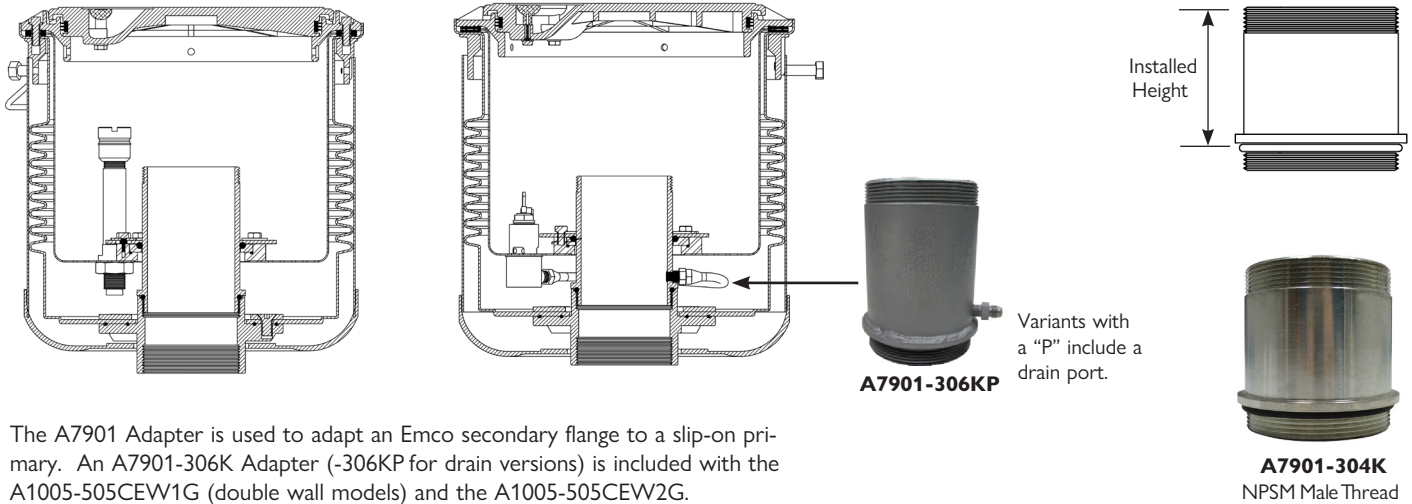

The A7901 Adapter is used to adapt an Emco secondary flange to a slip-on primary. An A7901-306K Adapter (-306KP for drain versions) is included with the A1005-505CEW1G (double wall models) and the A1005-505CEW2G.

Part No.	Installed Height	Description	Lbs.
A7901-304K	4.0"	A1005-505CEW1, CEW2	4.0
A7901-304KP	4.0"	A1005-505CEW1, CEW2	4.1
A7901-305K	5.0"	A1005-505CEW1, CEW2	4.5
A7901-306K	6.0"	A1005-505CEW1, CEW2	7.5
A7901-306KP	6.0"	A1005-505CEW1, CEW2	7.6

Retrofit

Replacement Parts

Part No.	Description	Lbs.
494845	O-ring Kit, A1005-505 Series Includes 2 O-rings	
495075	Flange/O-ring Kit, A1005-505C Includes 2-piece Ring Flange, Bolts, O-ring	1.0
495102	Flange/O-ring Kit, A1005-505 Series Includes 3-piece Ring Flange, Bolts, Washers, Eccentric Ring, 2 O-rings, Grounding Clip	1.9



494845
O-Ring Kit



495075
A1005-505C Kit



495271
A1005-505 Series Kit

Retrofit

Testing Equipment

Part No.	Description	Diameter	Lbs.
A1004-210TEST	Vacuum Test Apparatus	N/A	5.0
A0081-12TEST	Test Cover	12.40"	4.5
A0081-17TEST	Test Cover (-505CP)	17.38"	5.0

The A1004-210TEST is used with the A0081 Test Covers to perform vacuum testing on the A1005-505C Series Retrofit Spill Containment. For additional applications, refer to page 73.



A1004-210TEST

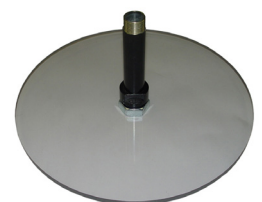

A0081-12TEST

Spill Containment

Riser Accessories

Riser Extensions

For use with thread-on spill containment.

The Emco A0031 Riser Extension adds height to existing riser pipes. Female NPT threads seal to the riser pipe and male NPT threads seal to thread-on spill containment manholes.

Part No.	Installed Height	Top Threads	Bottom Threads	Material	Lbs.
A0031-175X	1.75"	4" NPT	4" NPT	Steel	2.7
A0031-175XS	1.75"	4" NPT	4" NPT	SST	2.7
A0031-250X	2.50"	4" NPT	4" NPT	Steel	3.7
A0031-450X	4.50"	4" NPT	4" NPT	Steel	4.1

Custom sizes available upon request

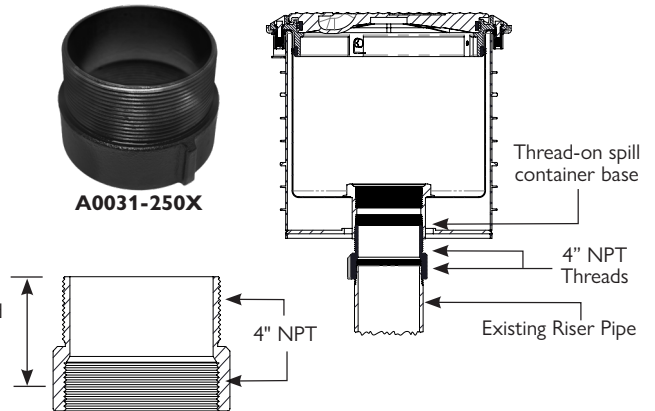

Riser Adapters

For use with slip-on spill containment.

The Emco A0031 Riser Adapter seals against an existing riser pipe with a 4" NPT female thread. The additional length of these riser adapters provide an Emco A1005-505 retrofit insert a clean surface to seal against. The riser adapters then terminate with a 4" NPSM male thread for a fill or vapor adapter.

Part No.	Installed Height	Top Threads	Bottom Threads	Material	Lbs.
A0031-450	4.50"	4" NPSM	4" NPT	Steel	4.1
A0031-625	6.25"	4" NPSM	4" NPT	Steel	4.4
A0031-725	7.25"	4" NPSM	4" NPT	Steel	6.4
A0031-825	8.25"	4" NPSM	4" NPT	Steel	7.9
A0031-900	9.00"	4" NPSM	4" NPT	Steel	9.0

Custom sizes available upon request

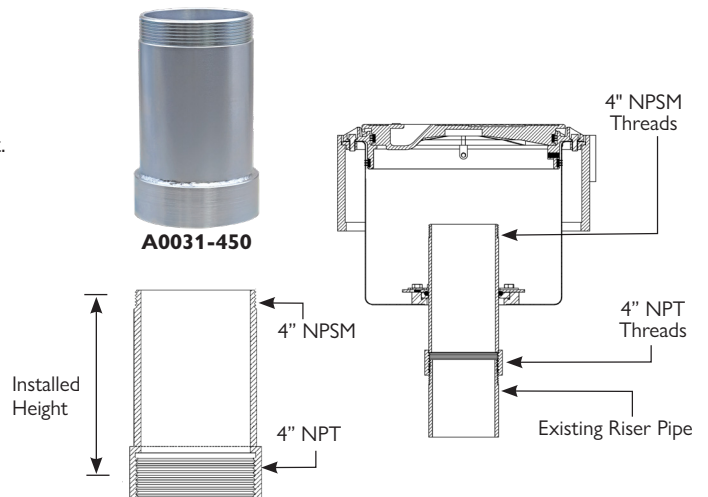

Riser Repair Adapter

The Riser Repair Adapter installs on corroded/damaged 4" NPT threads to provide undamaged 4" NPSM threads for a product adapter. Three set screws hold the Repair Adapter onto the damaged pipe.

Part No.	Installed Height	Top Threads	Bottom Threads	Lbs.
A0031-250R	2.50"	4" NPSM	4" NPT	3.7

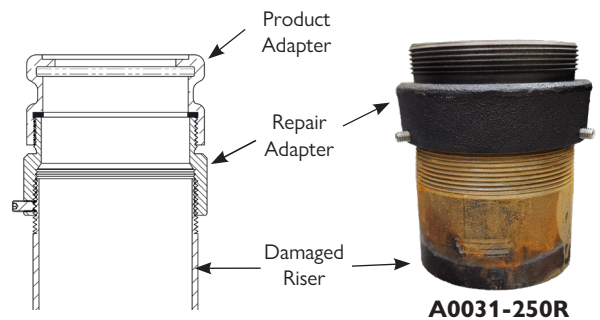

Adapter Extension - Stainless Steel

The Emco Wheaton A0031-200S Stainless Steel Riser Adapter Extension raises the adapter 2" closer to grade. The A0031-200S accommodates new and retrofit spill containment. The flat gasket seals against male thread of riser seal.

Part No.	Installed Height	Top Threads	Bottom Threads	Lbs.
A0031-200S	2.00"	4" NPSM	4" NPSM	1.7

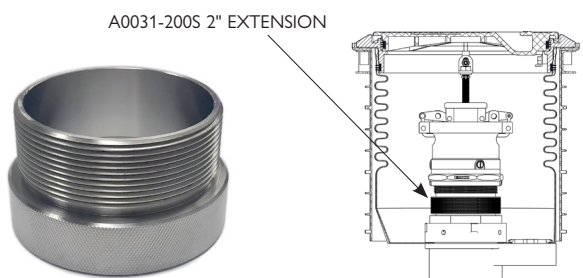

Spill Containment

Pipe Nipples and Couplings

A7901 4.1" Controlled I.D. Pipe Nipples

Emco A7901 Pipe Nipples hold a 4.173" controlled I.D. with 4" NPT top and bottom threads. Pipe nipples are machined from flame-controlled steel with no internal weld bead and painted with a protective black coating.

The controlled I.D. allows for pipe nipples to be used with submersible tank pumps and in Emco remote fill systems. These pipe nipples can also be used as an extension to a fill pipe in a spill container.

Custom sizes are available on request.

Part Number	Weight (Lbs.)	Length A
A7901-004	2.5 lbs.	4"
A7901-005	3.4 lbs.	5"
A7901-006	4.2 lbs.	6"
A7901-007	5.1 lbs.	7"
A7901-008	5.9 lbs.	8"
A7901-012	9.4 lbs.	12"
A7901-018	14.5 lbs.	18"
A7901-024	19.7 lbs.	24"
A7901-030	24.9 lbs.	30"

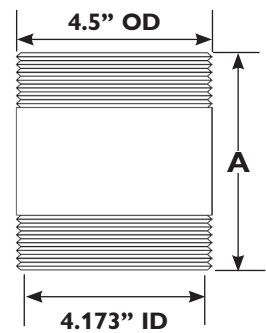

A7901: Controlled ID

4.026" ID

A7940: Sch 40

A7940 Schedule 40 Pipe Nipples



Emco A7940 Pipe Nipples are a traditional 4" schedule 40 seam welded pipe nipple with 4" NPT top and bottom threads. **A7940 Pipe Nipples are available in black painted steel or stainless steel.** Custom sizes are available on request.

A7940 Steel Pipe Nipples

Part Number	Weight (Lbs.)	Length A
A7940-004C	2.0 lbs.	4" close
A7940-006	4.5 lbs.	6"
A7940-012	9.6 lbs.	12"
A7940-018	13.6 lbs.	18"
A7940-024	18.1 lbs.	24"
A7940-030	22.6 lbs.	30"
A7940-036	27.1 lbs.	36"
A7940-042	31.6 lbs.	42"
A7940-048	36.2 lbs.	48"

A7940 Stainless Steel Pipe Nipples

Part Number	Weight (Lbs.)	Length A
A7940-004CSS	2.0 lbs.	4" close
A7940-006SS	4.5 lbs.	6"
A7940-012SS	9.5 lbs.	12"
A7940-018SS	13.4 lbs.	18"
A7940-024SS	17.8 lbs.	24"
A7940-030SS	22.3 lbs.	30"
A7940-036SS	26.7 lbs.	36"
A7940-042SS	31.2 lbs.	42"
A7940-048SS	35.6 lbs.	48"

Pipe Couplings

Emco A7904 Pipe Couplings have 4" NPT female top and bottom threads. Pipe couplings are steel with a protective black coating; some options are available in stainless steel. The A7904-004 includes a full thread on both sides. The A7904-500 has truncated NPT threads for low profile applications; it only adds .250" in height.

Model No.	Height	Lbs.
A7904-500	2.38"	2.9
A7904-004	3.50"	4.5
A7904-004SS	3.50"	4.5



A7904-500 Short Pipe Coupling

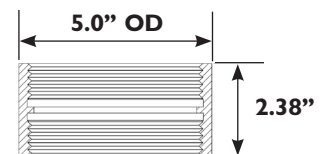

A7904-004 Merchant Steel Coupling

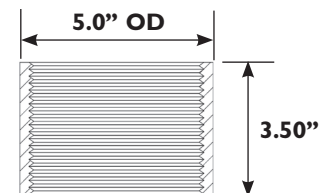

Spill Containment Replacement Parts

Spill Containment Model No.	Drain Assembly	Drain Plug Kit	Drain Adapter
Replaceable			
A1004 Poly	494551*	494697P*, 494697*	494875
A1004EVR 5 gal	494118P	495202, 494698	N/A
A1004EVR 15 gal	494118P	495202, 494698	N/A
A1005-505 SST Retrofits	494551S*	494697S*	N/A
A1005 Stainless Steel	493508PK	495202, 494698	N/A
Non-Replaceable			
A1003 Poly	N/A	495677*	N/A
A1004 Slimline, Fatboy	493508PK	495202, 494698	N/A
A1004EVR Slimline	494118P	495202, 494698	N/A

*No longer used in new spill containers; limited supply available for replacement parts.

Drain Assemblies

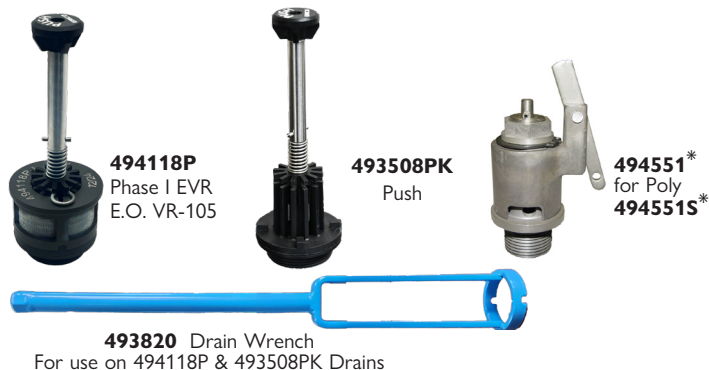

Drain Plug Kits



Drain Adapter



EZ-Gage



Model No.	Description
A1004-001GAGE	Screw-on, brass
A1004-001GAGE-T	Telescoping, push-on, anodized aluminum <i>Required in New Hampshire</i>

495625 O-ring Replacement Kit, brass body EZ-Gage
495996 O-ring Replacement Kit, aluminum body EZ-Gage

Electronic Sensor

Easy access to sensor eliminates bucket removal for annual sensor testing. Provides an access to remove liquid, and for interstitial vacuum testing from the secondary containment. Includes factory-installed liquid electronic sensor with 30' cable.

Accommodates the Veeder Root system. Contact Customer Service for information on ordering sensors for other systems.

Model No.	Description	Lbs.
A1004-001SEN-S	SST Sensor Kit, Veeder-Root	1.2
A1004-001SEN-NR	SST Sensor Kit, Pneumercator	1.2
494890	Sensor Test Port Cap	1.0

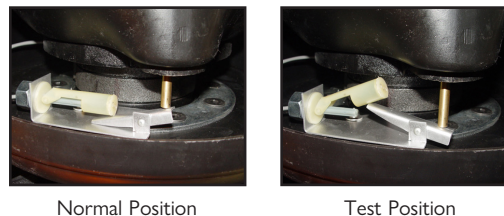

Spill Containment

Replacement Parts

Replacement Kits and Parts - A1004 Replaceable

Model No.	Description	Lbs.
A1004EVR-210		
5 Gal Poly		
494360EVR	Primary Replacement Kit (EVR-210A, SW/Drain)	40.3
494466EVR	Primary Replacement Kit (EVR-211A, SW/Drain Plug)	40.3
494467EVR	Primary Replacement Kit (EVR-210S*, 211S, DW/Drain Plug) Refer to drawing at right	41.6
494467EVR-S	Primary Replacement Kit (EVR-210S*, 211S, DW/Drain Plug) Refer to drawing at right	41.6
494467EVR-CM	Prmy Rplcmt Kit (EVR-210S-CM*, 211S-CM, DW/Drn Plug/Sensor) Refer to drawing at right	41.4
494993S	Primary/Secondary Replacement Kit (EVR-210S, DW/Drain)	54.1
494993S-ND	Primary/Secondary Replacement Kit (EVR-210S, DW/No Drain)	53.3
570226	Rim Gasket	0.3
*494118	Drain Kit, Converts Drain Plug to Drain Refer to page 51 for stainless steel retrofit kits	0.2
A1004EVR-216		
15 Gal EVR SST/Poly		
494660EVR-S	Primary & Secondary Replacement Kit (EVR-216SJ, DW/No Drain)	133.0
495880	Kit Spacer 3/4", A1004EVR-215/216	16.0
496026-1	Primary Replacement Kit (-216A, SW/No Drain, Non-EVR)	90.0
569989	Flat Rim Gasket Ø15"	0.3
570069	Flat Rim Gasket Ø22"	0.4
573728	Rim Adapter Triple Wiper Seal	0.4
A1004EVR-316/317		
5 Gal Poly, 16" Center		
494797EVR	Primary Replacement Kit (EVR-316A, SW/Drain)	37.8
494798EVR	Primary Replacement Kit (EVR-317A, SW/No Drain)	37.0
494794EVR	Primary Replacement Kit (EVR-316S, DW/Drain)	38.4
494794EVR-CM	Primary Replacement Kit (EVR-316S-CM, DW/Drain/Sensor)	38.2
494795EVR	Primary Replacement Kit (EVR-317S, DW/No Drain)	37.6
494795EVR-CM	Primary Replacement Kit (EVR-317S-CM, DW/No Drain/Sensor)	37.4
495696DWVP	Secondary Replacement Kit (EVR-316S, -317S, DW)	49.2
494888SS	Lid Handle Kit	0.5
569989	Rim Gasket	0.3
570587	Rim Screw	
572819-025	Rim Spacer Kit, 1/4"	5.3
572819-037	Rim Spacer Kit, 3/8"	6.5
572819-050	Rim Spacer Kit, 1/2"	7.7
572819-100	Rim Spacer Kit, 1"	8.9
572819-100ALT	Rim Spacer Kit, 1" Multi-piece	9.5
Refer to page 51 for stainless steel retrofit kits		
A1004EVR-317SS		
5 Gal Stainless Steel/Poly, 16" Center		
494836SS	Primary Rim Kit	14.3
494795EVRSS	Primary Replacement Kit SST (EVR-317SS, DW/No Drain)	36.5
494795EVRSS-CM	Pmry Rplcmt Kit SST (EVR-317SS-CM, DW/No Drn/Sensor)	20.9
495558K	Flange/O-ring Kit	0.8
495696EVO	Secondary Replacement Kit (EVR-317SS, DW)	14.0

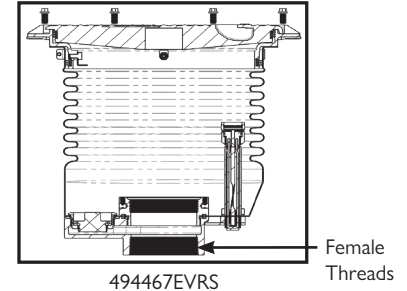
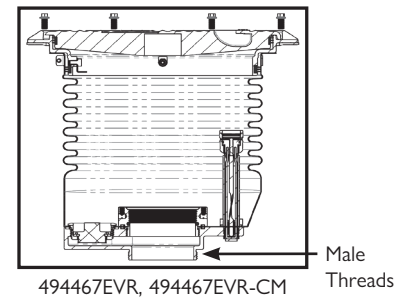
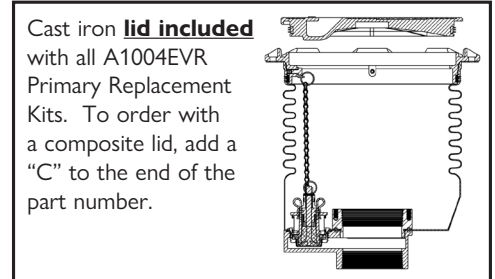

Spill Containment Replacement Parts

Replacement Kits and Parts - A1005 Replaceable

Model No.	Description	Lbs.
A1005-517/518	5 Gal Stainless Steel	
494836SS	Rim Kit	14.3
494845	O-ring Kit	0.1
494897	Flange Seal, A1005-517GS	0.2
494836	Primary Rim Kit (lid not included)	16.0
495075	Mounting Kit, Non-Eccentric Ring	1.0
495102	Mounting Kit, Eccentric Ring	2.0
495104	Primary Replacement Kit, Stainless Slip-on A1005-517G/-517GS	35.0
495229	Mounting Kit, A1005-517GS	3.8
495370X	Primary Replacement Kit, (w/lid) A1005-518GP	35.0
495370	Primary Replacement Kit, (w/o lid) A1005-518GP	11.0
495524	Bellows Gasket Kit, A1005-518GP	1.0
495644	Conversion Kit, A1005-518GP to A1004EVR-317SS	23.0
496059	Secondary Replacement Kit, Stainless Slip-on A1005-517G/-517GS	12.0
496113	Primary & Secondary Replacement Kit, Stainless/Stainless Slip-on A1005-517G/-517GS	56.0
569989	Rim Gasket	0.3
A1005-616	15 Gal Non-EVR SST/Poly	
496026-2	Primary & Secondary Non-EVR Replacement Kit	124.0
495880	Kit Spacer 3/4", A1004EVR-215/216	16.0
570069	Flat Rim Gasket Ø22"	0.4
569989	Flat Rim Gasket Ø15"	0.3
573728	Rim Adapter Triple Wiper Seal	0.4



494845
O-Ring Kit



495229
Mounting Kit

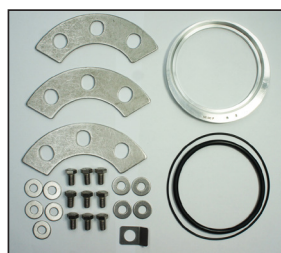

495102
Mounting Kit

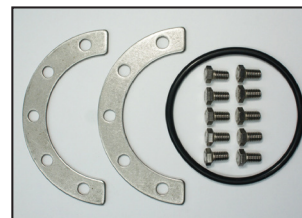

495075
Mounting Kit

A1004/A1005 Non-Replaceable



Model No.	Description	Lbs.
A1004-010	5 Gal Slimline	
A1005-505CEW3	Stainless Steel Retrofit (refer to page 53)	26.0
A1005-001		
493855	Bellows Assembly 4"	1.4

Spill Containment

Replacement Parts

Lids













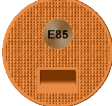

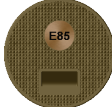

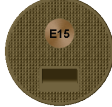
A1004EVR-316 & -317, A1005-517 & -518 Series

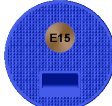
Description	Seal	Lid Dia.	Cast Iron Lid Model No.	Lbs.	Composite Lid Model No.	Lbs.
Black	570012	13.2"	A1004-316CLID 	15.9	A1004-316LID 	6.6
Black	570012	13.2"	A1004-316CLID-BE0 	15.9		
White, Regular	570012	13.2"	A1004-316CLID-REG 	15.9	A1004-316LID-REG 	6.6
White, Regular	570012	13.2"	A1004-316CLID-R 	15.9	A1004-316LID-R 	6.6
White, E0	570012	13.2"	A1004-316CLID-E0 	15.9	A1004-316LID-E0 	6.6
White, E85	570012	13.2"	A1004-316CLID-EW 	15.9		
Yellow, ULSD	570012	13.2"	A1004-316CLID-D 	15.9	A1004-316LID-D 	6.6
Yellow, ULSD	570012	13.2"	A1004-316CLID-ULSD 	15.9	A1004-316LID-ULSD 	6.6
Red, Premium	570012	13.2"	A1004-316CLID-U 	15.9	A1004-316LID-U 	6.6
Red, Premium	570012	13.2"	A1004-316CLID-ULT 	15.9	A1004-316LID-ULT 	6.6
Red, E0-90	570012	13.2"	A1004-316CLID-UC 	15.9	A1004-316LID-UC 	6.6
Red, E0	570012	13.2"			A1004-316LID-UZ 	6.6

Spill Containment

Replacement Parts

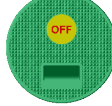
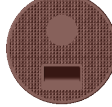
Lids

Description	Seal	Lid Dia.	Cast Iron Lid Model No.	Lbs.	Composite Lid Model No.	Lbs.
Orange, Vapor	570012	13.2"	A1004-316CLID-V 	15.9	A1004-316LID-V 	6.6
Orange, E85	570012	13.2"	A1004-316CLID-EV 	15.9	A1004-316LID-EV 	6.6
Bronze, E85	570012	13.2"	A1004-316CLID-E 	15.9	A1004-316LID-E 	6.6
Bronze, E15	570012	13.2"	A1004-316CLID-E15 	15.9	A1004-316LID-E15 	6.6
Blue, E15	570012	13.2"	A1004-316CLID-MF 	15.9		
Blue, DEF	570012	13.2"	A1004-316CLID-DEF 	15.9	A1004-316LID-DEF 	6.6
Blue, Mid-Grade	570012	13.2"	A1004-316CLID-M 	15.9		
Light Blue, Biodiesel	570012	13.2"	A1004-316CLID-BD 	15.9		
Purple, Racing Fuel	570012	13.2"			A1004-316LID-RF 	6.6
Green, Off Road Diesel	570012	13.2"	A1004-316CLID-D1 	15.9		
Brown, Kerosene	570012	13.2"	A1004-316CLID-K 	15.9		
Brown, Kerosene	570012	13.2"	A1004-316CLID-KER 	15.9		

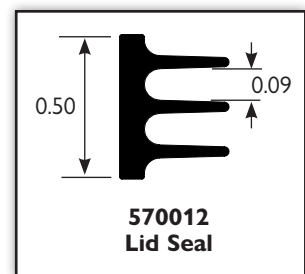

Spill Containment

Replacement Parts

Lids

A1004EVR-210 Series

Description	Seal	Lid Dia.	Cast Iron Lid Model No.	Lbs.	Composite Lid Model No.	Lbs.
Black	571815	15.3"	A1004-210LID	20.0	A1004-210LID-C	8.3
Yellow, ULSD	571815	15.3"	A1004-210LID-D	20.0	A1004-210LID-CD	8.3
White, Regular	571815	15.3"	A1004-210LID-R	20.0	A1004-210LID-CR	8.3
Red, Ultra/Premium	571815	15.3"	A1004-210LID-U	20.0	A1004-210LID-CU	8.3
Orange, Vapor	571815	15.3"	A1004-210LID-V	20.0	A1004-210LID-CV	8.3

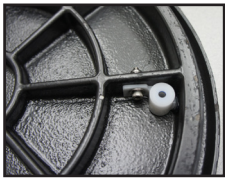
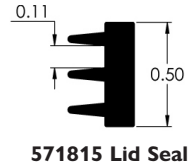

Vent Valve Installed In All Lids

495067K Vent Valve Replacement Kit

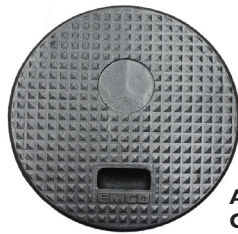

A1004-210LID
Cast Iron



A1004-210LID-C
Composite

15 Gallon Series; Non-Replaceable Series

Spill Containment Model No. Series	Cast Iron Lid Model No.	Seal	Lid Dia.	Lbs.
A1004EVR-215	494554	569227	17.3"	29.5
A1005-010TM	494554	569227	17.3"	29.5
A1003	493123	571126	15.8"	19.1
A1004-010	A1004-210LID	571815	15.3"	20.0
A1005-001, -501	A1004-210LID	571815	15.3"	20.0

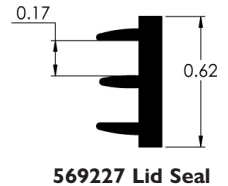

493123
A1003 Series
Replacement



A1004-210LID
A1004 Slimline



494554
15 Gallon



A1003 Lid
Original

A1005-505 Retrofit

Spill Containment Model No.	Cast Iron Lid Model No.	Lid Seal	Lid Dia.	Lbs.
A1005-505C, CD, C5, CBG, CS, CZ	A1005-505CL	568961	13.7"	16.6
A1005-505C4	A1005-505CL4	568961	12.4"	12.3
A1005-505CA, CAZ	A1005-505CAL	568961	13.7"	16.6
A1005-505CC, CC5	A1005-505CCL	568961	12.4"	16.6
A1005-505CE, CE15, CES	A1005-505CEL	568961	13.7"	16.6
A1005-505CEW1, CEW1DR	A1004-210LID	571815	15.3"	20.0
A1005-505CEW2, CEW2DR, CEW4	A1004-316CLID	570012	13.1"	15.9
A1005-505CEW3	A1005-505CEW3L	568961	13.4"	14.9
A1005-505CF1	A1005-505CFL1	568961	13.9"	16.5
A1005-505CF5	A1005-505CF5L	568961	13.5"	15.2
A1005-505CP	A1005-505CPL	570012	17.6"	24.5
A1005-505CP1	A1005-505CPL1	573114*	11.9"	12.0
A1005-505CPEM, CPED	A1005-505CPEML	568961	12.4"	13.3
A1005-505CU	A1005-505CUL	568961	12.4"	13.4
A1005-505CU70	A1005-505CUL70	568961	15.0"	16.9

*For lids with Emco logo handle only



A1005-505CL

A1005-505 Series Lid Seals

Measure inside diameter as shown

- 10 3/8" - 10 1/2" 568961 Seal
- 12 3/4" - 13" 570012 Seal

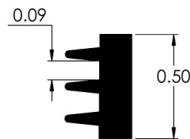

568961 Lid Seal
570012 Lid Seal

Spill Containment

Spill Containment Accessories

A0028 Riser Lock

The Emco Wheaton A0028-001 Riser Lock is designed to lock the riser pipe in place when removing manholes or adapters. Can be used on 3" and 4" pipe.

Model No.	Description	Lbs.
A0028-001	Standard	5.4
A0028-001C	Glass-on, for NOV riser pipes	2.1



A0028-001



A0028-001C

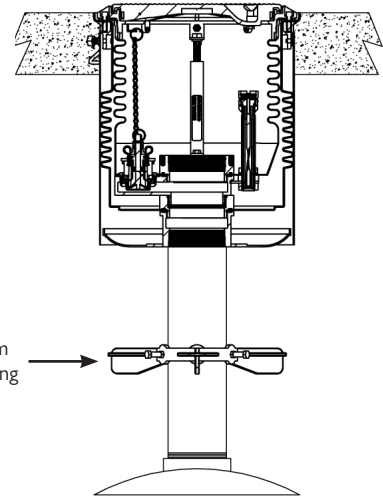

Prevents riser pipe from backing out of tank fitting

A0333 Hand Pump

The Emco Wheaton A0333 Hand Pump is a thermoplastic self-venting pump. The A0333-002 is acceptable for use with A1003, A1004 and A1005 Spill Containment.

Model No.	Description	Lbs.
A0333-002	Hand Pump	1.3
A0333-004	Hand Pump w/ Mounting Bracket for A1005-501	3.0



TOOLS & TEST
EQUIPMENT

Tools

A0081 Wrench

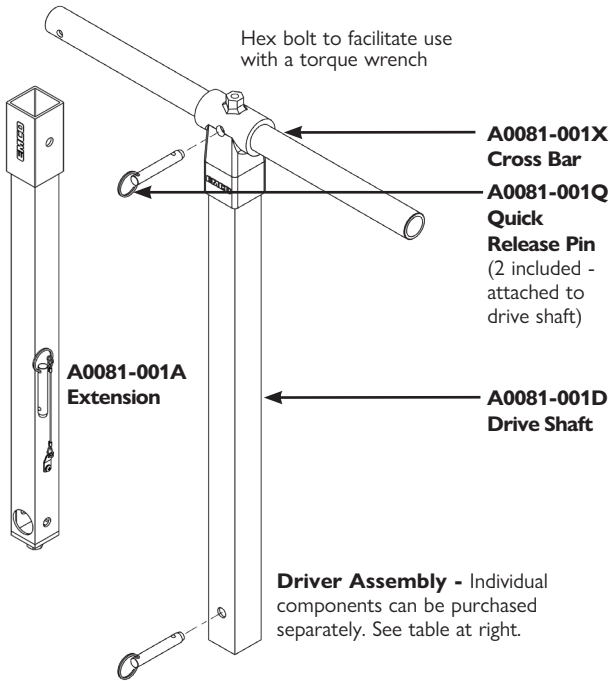

Emco Wheaton A0081Wrenches are specially designed for the installation and repair of Emco Wheaton spill containers and adapters. Wrenches are available as complete units. Components can also be purchased individually. The A0081-001SET is a standard tool kit; components listed on following page. The wrenches are steel construction, powder coated blue.

Model No.	Application	Lbs.
Tool Box Set		
A0081-001SET	Standard Tool Kit	92.3
A0081-001SET-NB	Standard Tool Kit w/o Tool Box	38.8
Complete Wrenches		
A0081-001	Swivel Adapter	16.7
A0081-001H	Spill Container (w/Drain)	11.2
A0081-001L	Lug Adapter	13.1
A0081-001R	Retrofit Spill Container	17.6
A0081-001S	Secondary Flange Removal	20.5
A0081-003	Pipe Nipple Extractor	14.3
A0081-003M	Spill Container (w/o Drain)	23.5
A0081-009	Chain Wrench Adapter	13.8
Individual Components		
A0081-001B	Swivel Adapter Bit	5.6
A0081-001HB	Spill Container (w/Drain) Bit	5.2
A0081-001LB	Lug Adapter Bit	2.0
A0081-001RB	Retrofit Spill Container Bit	6.5
A0081-001SB	Secondary Flange Removal Bit	7.5
A0081-003B	Pipe Nipple Extractor Bit	3.1
* A0081-003MB	Spill Container (w/o Drain) Bit	12.0
A0081-009B	Chain Wrench Adapter Bit	2.7
A0081-001A	Drive Shaft Extension	6.3
A0081-001D	Drive Shaft	7.0
A0081-001X	Cross Bar	4.2
A0081-001Q	Quick Release Pin	0.1
A0081-001TB	Tool Box (empty)	53.5

* Must have an A0081-001A to function.

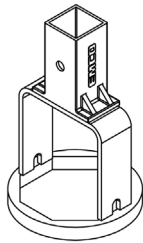

A0081-001B

A0081-001 Swivel Adapter Wrench

Use to install and remove fill and vapor adapters with octagonal bases, and the 494096 Riser Seal. Fits all competitor fill and vapor adapters.

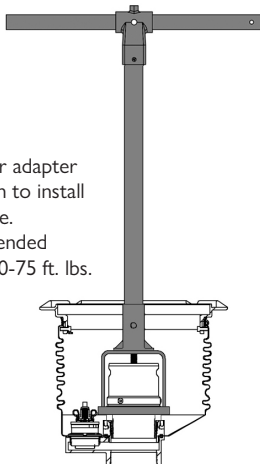

Place over adapter base. Turn to install or remove.
Recommended torque: 60-75 ft. lbs.



A0081-001LB

A0081-001L Lug Adapter Wrench

Use to install and remove fill adapters with lugs. Use to adjust the center insert of the 494096 Riser Seal. Replaces the 494120 Riser Seal Wrench. Fits OPW 3" and 4" adapters.

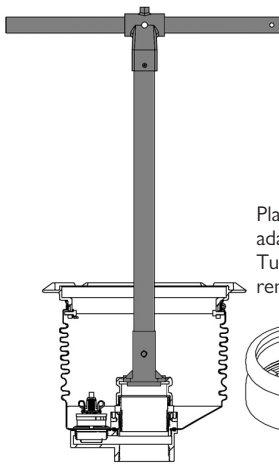

Place over adapter lugs. Turn to install or remove.

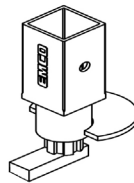

A0081-001HB

A0081-001H Spill Container (w/Drain) Wrench

Use for installation and removal of spill containers.

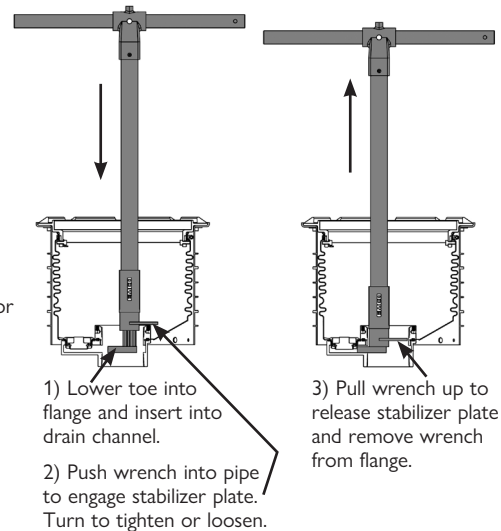

A0081 Wrench



A0081-001SET Standard Tool Kit

- A0081-001A Drive Shaft Extension
- A0081-001D Drive Shaft
- A0081-001X Cross Bar
- A0081-001B Swivel Adapter Bit
- A0081-001HB Spill Container Bit
- A0081-001LB Lug Adapter Bit
- A0081-001SB Secondary Flange Removal Bit
- A0081-003B Pipe Nipple Extractor Bit
- A0081-003MB Spill Container (w/o Drain) Bit
- A0081-009B Chain Wrench Adapter Bit
- A0081-001TB Tool Box

Box - 44"x15"x12"; Overall - 48"x16"x12"

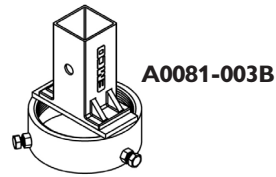

**A0081-003
Pipe Nipple Extractor**

Use to remove and install 4" pipe nipples.



**A0081-009
Chain Wrench Adapter**

Use with a chain wrench to tighten or loosen fittings, valves, risers and nipples.

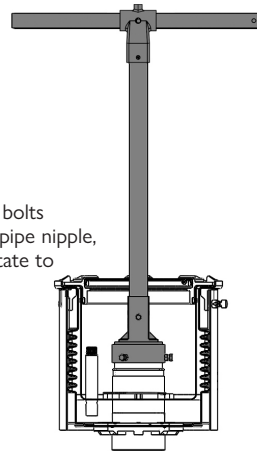

Tighten bolts around pipe nipple, then rotate to extract.

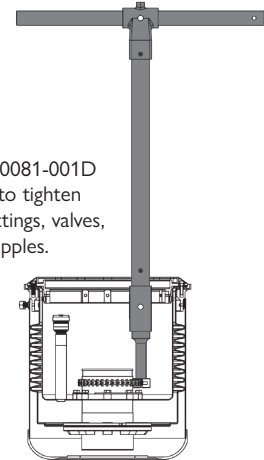

Attach to A0081-001D Drive Shaft to tighten or loosen fittings, valves, risers and nipples.

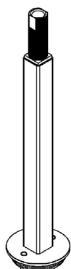

A0081-003MB

* Must have an A0081-001A to function.

**A0081-003M
Spill Container (w/o Drain) Wrench**

Use for installation and removal of spill containers without drains.

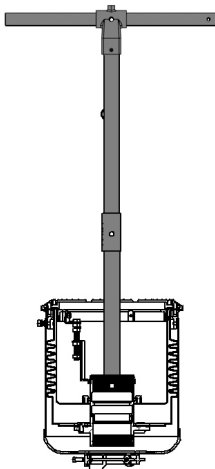

A0081-001SB

**A0081-001S
Secondary Flange Removal Wrench**

Use to remove secondary containment assemblies.

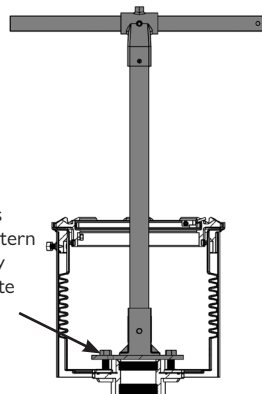

Tighten bolts into hole pattern on secondary flange - rotate to remove.

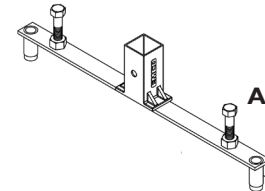

A0081-001RB

**A0081-001R
Retrofit Lid Wrench**

Required for installation of A1005-516R/-518R Retrofit Spill Containment (OPW 500/700 retrofit). **Not included in standard tool kit.**

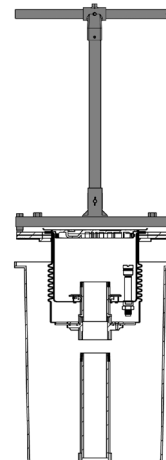

Tools

Tools

493820 Drain Wrench

The 493820 Drain Wrench is used for installation and removal of the Emco Wheaton A1004EVR Spill Containment drain valves.



494240 Adapter Torque Wrench

The 494240 is used to verify the static torque of the swivel adapter in accordance to CARB Test Procedure TP.201.1B



566675 Drill Fixture

The 566675 Drill Fixture is used to accurately drill the rivet holes on the top drop tube for the Emco Wheaton A1100EVR collar assembly.



A0081-004CL Cam-Lock Wrench

The A0081-004CL Cam-Lock Wrench is used to install and remove the A0716 Composite Manhole cam-lock lids.



569427 Euro Lift Handle

The 569427 Euro Lift Handle fits into the keyhole to lift the A0716 Composite Manhole cam-lock lids.



496360 A1100 Upright Functional Test Kit

The 496360 test kit includes all the parts, tools, and instructions necessary to perform the A1100 upright functional test on any Emco OPV.



A0081-009C Chain Wrench

The 3/4" square drive 26" long chain bit is compatible with diameters up to 8".



A0081-009SET

Chain Wrench + Chain Wrench Adapter Bit

**A0081-001D Drive shaft not included.*

Test Equipment

Test Equipment

A0081-1100 A1100 Testing Tool

The A0081-1100 Testing Tool is used to quickly and easily test the A1100-T series Testable Overfill Prevention Valve, without removing the valve from the riser.



A0081 Test Cover

The A0081 Test Cover is used with the Emco A1004-210TEST to perform vacuum testing on spill containment.

Part No.	Spill Containment	Diameter	Lbs.
A0081-12TEST	A1005-505 Series	12.40"	4.5
A0081-13TEST	A1004-316/517 Series	13.13"	4.5
A0081-15TEST	A1004-210 Series	15.25"	4.7
A0081-17TEST	A1004-215 Series, A1005-505CP	17.38"	5.0

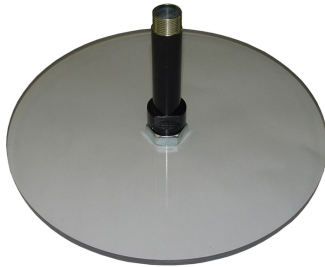

A0099-001TEST Vapor Test Cap

The A0099-001TEST Vapor Test Cap is used when performing a pressure decay test. The cap incorporates the same features as the A0099-002 Vapor Cap. The extended tube underneath the cap opens the poppet on the vapor adapter. Pressure is injected through the Schrader valve, and a gauge can be connected to the barbed fitting.



A1004-210TEST Vacuum Apparatus w/Test Adapter

The A1004-210TEST is designed to perform vacuum testing on interstitial space in double wall spill containment. 5 lbs.

Model No.	Description
A1004-210TEST	Vacuum Test Apparatus
494343	Test Adapter
569143	Test Cap Assembly
569194	Air Switch 1/8"
569195	Air Regulator 1/8"



494343
Test Adapter



569143
Test Cap



569194
Air Switch



569195
Air Regulator

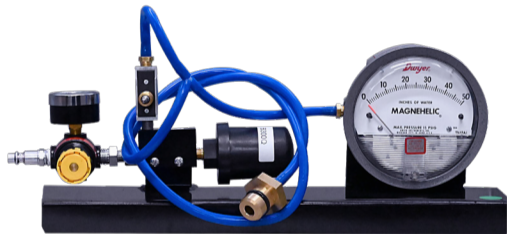

A1004-210TEST
Test Apparatus

MANHOLES

Composite Manholes

A0716 Composite Manholes

The Emco Wheaton A0716 Composite Manhole is designed with lightweight, slip-resistant composite manhole covers, using the latest manufacturing technology to ensure porosity-free molding, and compact, homogeneous distribution of reinforcing fiber. The covers also utilize a UV resistant treatment to protect against sun and weather damage.

Features:

- 1 Meets AASHTO H20 Wheel Loading
- 2 Non-skid surface
- 3 Stainless steel cam-lock fittings, field replaceable
- 4 Stainless steel pry bar cleat

39", 42", & 44" Models

- 5 Two stainless steel dual handles - spring-loaded and key-lift
- 6 Domed top construction to shed water
- 7 Black painted hot rolled steel skirt
- 8 Concrete anchors

A0716 Customization Options:

- Black or grey colorway
- Black painted hot rolled steel rim or heavy duty composite rim in black or grey
- Black painted hot rolled steel skirt or rigid black HDPE skirt

A0716 manholes are constructed with a black painted hot rolled steel rim and skirt and a black composite lid by default.

See page 78 for more details on A0716 customization.

Emco Composite lids have a 36 month warranty!



Serial Number

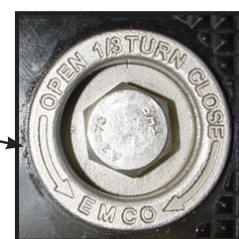
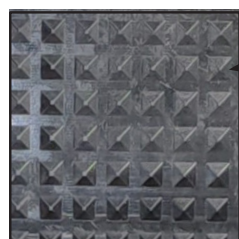
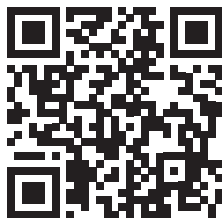

The ManholeTrak Warranty Tracking System is available on our website, www.emcoretail.com or by scanning the QR code above.

Composite Manholes

A0716 Composite Manholes

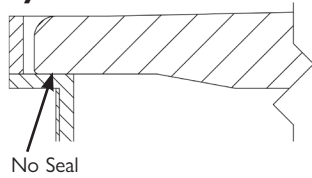
Seal Options	Model Number	Size	Style	Rim/Lid Color	Lid Dia. "A"	Overall Dia. "B"	Clear Hole I.D. "C"	Skirt I.D. "D"	Overall Ht. "E"
Lay-In  <p>No Seal</p>	A0716-018	18"	Lay-in	Black	17.0"	19.1"	15.1"	17.5"	10.6"
	A0716-018LID	18"	Lid Only Lay-in	Black	17.0"	--	--	--	--
	A0716-020	20"	Lay-in	Black	20.0"	20.8"	18.3"	18.6"	9.8"
	A0716-020LID	20"	Lid Only Lay-in	Black	20.0"	--	--	--	--
	A0716-039	39"	Lay-in	Black	39.5"	40.3"	37.8"	38.3"	10.3"
	A0716-039LID	39"	Lid Only Lay-in	Black	39.5"	--	--	--	--
	A0716-042	42"	Lay-in	Black	43.8"	44.6"	42.0"	42.5"	10.3"
	A0716-042LID	42"	Lid Only Lay-in	Black	43.8"	--	--	--	--
A0716-044	44"	Lay-in	Black	44.3"	44.9"	42.4"	42.9"	10.3"	
A0716-044LID	44"	Lid Only Lay-in	Black	44.3"	--	--	--	--	

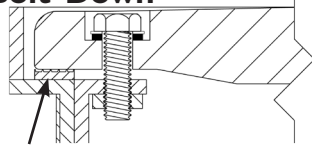
Bolt-Down  <p>Ribbed Seal, Water-resistant</p>	A0716-039B	39"	Bolt-down	Black	39.5"	40.3"	34.7"	38.3"	10.3"
	A0716-039BL	39"	Lid Only Bolt-down	Black	39.5"	--	--	--	--
	A0716-042B	42"	Bolt-down	Black	43.8"	44.6"	39.0"	42.5"	10.3"
	A0716-042BL	42"	Lid Only Bolt-down	Black	43.8"	--	--	--	--
	A0716-044B	44"	Bolt-down	Black	44.3"	44.9"	39.4"	42.9"	10.3"
	A0716-044BL	44"	Lid Only Bolt-down	Black	44.3"	--	--	--	--

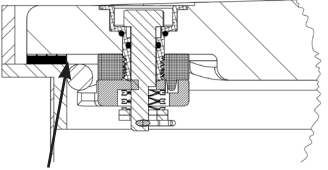
Cam-Lock  <p>Ribbed Seal, Water-resistant</p>	A0716-018C	18"	Cam Lock	Black	17.0"	19.1"	15.1"	17.5"	10.6"
	A0716-018CL	18"	Lid Only Cam Lock	Black	17.0"	--	--	--	--
	A0716-018CWL	18"	Lid Only White Cam Lock	Black	17.0"	--	--	--	--
	A0716-039C	39"	Cam Lock	Black	39.5"	40.3"	36.9"	38.3"	10.3"
	A0716-039CL	39"	Lid Only Cam Lock	Black	39.5"	--	--	--	--
	A0716-042C	42"	Cam Lock	Black	43.8"	44.6"	41.0"	42.5"	10.3"
	A0716-042CL	42"	Lid Only Cam Lock	Black	43.8"	--	--	--	--
	A0716-044C	44"	Cam Lock	Black	44.3"	44.9"	41.9"	42.9"	10.3"
A0716-044CL	44"	Lid Only Cam Lock	Black	44.3"	--	--	--	--	

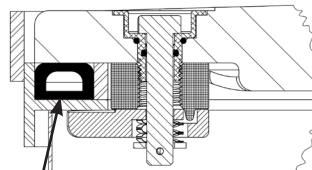
Cam-Lock-D  <p>D-Seal, Water-tight</p>	A0716-024CD	24"	Cam Lock w/D-Seal	Black	24.0"	29.5"	22.0"	25.2"	10.0"
	A0716-039CD	39"	Cam Lock w/D-Seal	Black	39.5"	40.4"	36.8"	38.3"	11.1"
	A0716-042CD	42"	Cam Lock w/D-Seal	Black	43.8"	44.6"	41.0"	42.5"	11.1"
	A0716-044CD	44"	Cam Lock w/D-Seal	Black	44.3"	44.9"	41.8"	43.7"	11.1"

*Most common variant
 Custom skirt heights available upon request

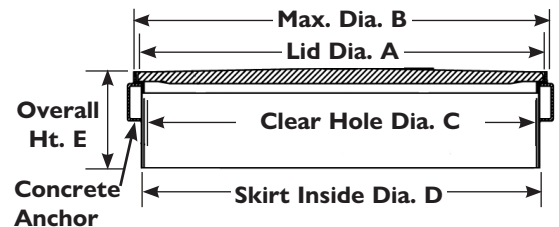

All composite manholes require a 3/4" socket for installation and maintenance.

Replacement Parts

Model No.	Description
570897	Rib Seal, -018C
495157	Rib Seal, -039B, -039C
494988	Rib Seal, -042B, -042C, -044B, -044C
495561	D-Seal, -039CD
495562	D-Seal, -042CD, -044CD
494781K	Cam-Lock Assembly; -039C, -042C, -044C
494781LK	Cam-Lock-D Assembly; -039CD, -042CD, -044CD

Composite Manholes

A0716 Composite Manhole Customizations

Emco composite manholes are available in an array of different options. Read more about our A0716 customizations below.

Greyline

A0716 manhole lids are available in Black or Grey for all sealing options of the 44" manholes. See page 79 for part numbers.

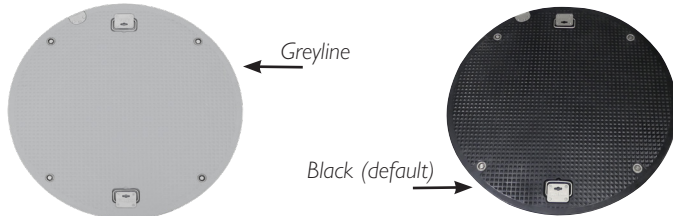

Typical Summer day

Greyline composite lids are interchangeable with existing Emco black composite lids.

Composite Rim

A0716 manholes are available with a black painted hot rolled steel rim or a lightweight, robust composite rim made from the same material as the A0716 Manhole lid. Composite rims are available in the 44" sizes, black or grey in color, for Lay-in and water resistant Cam-lock styles. Bolt down and water-tight cam-lock are not available with the composite rim. See page 79 for part numbers.



HDPE Skirt

A0716 manholes are available with a black painted hot rolled steel skirt or a rigid, heavy-duty HDPE skirt. HDPE Skirts are available for any 44" A0716 manhole. **Add the suffix "-HDPE" to any applicable A0716 part number to order your manhole with an HDPE skirt.**



TRADITIONAL SHIPPING

4 units
44"x44"x48"

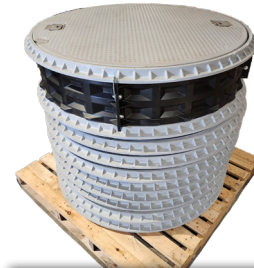

COMPACT SHIPPING

10 units
52"x52"x47"

The nesting skirt design allows for compact shipping and lightweight lifting. **Add the suffix "-HDPEB" to the end of any applicable A0716 part number to order your manhole with an HDPE skirt and compact shipping.**

HDPE skirt sections are designed with molded in concrete anchors.

All Emco Composite lids have a 36 month warranty!



Serial Number



The ManholeTrak Warranty Tracking System is available on our website, www.emco-retail.com or by scanning the QR code above.



HDPE skirt sections are stackable to make a double height skirt. Skirt height extensions can be completed in the field with the HDPE skirt extension kit. See page 79 for part numbers.

Composite Manholes

A0716 Composite Manhole Customizations

Seal Options	Model Number	Size	Style	Rim/Lid Color	Lid Dia. "A"	Overall Dia. "B"	Clear Hole I.D. "C"	Skirt I.D. "D"	Overall Ht. "E"
Lay-In  No Seal	A0716-044N	44"	Lay-in	Black	44.3"	45.7"	42.1"	42.9"	10.9"
	A0716-044NT	44"	Lay-in Tall Skirt	Black	44.3"	45.7"	42.1"	42.9"	18.4"
	A0716-044LID	44"	Lid Only Lay-in	Black	44.3"	--	--	--	--

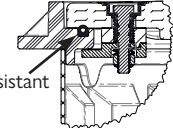
Seal Options	Model Number	Size	Style	Rim/Lid Color	Lid Dia. "A"	Overall Dia. "B"	Clear Hole I.D. "C"	Skirt I.D. "D"	Overall Ht. "E"
Cam-Lock  Seal Water-resistant	A0716-044CN	44"	Cam-Lock	Black	44.3"	45.7"	42.1"	42.9"	10.9"
	A0716-044CNT	44"	Cam-Lock Tall Skirt	Black	44.3"	45.7"	42.1"	42.9"	18.4"
	A0716-044CL	44"	Lid Only Cam-Lock	Black	44.3"	--	--	--	--

Greyline

Seal Options	Model Number	Size	Style	Rim/Lid Color	Lid Dia. "A"	Overall Dia. "B"	Clear Hole I.D. "C"	Skirt I.D. "D"	Overall Ht. "E"
Lay-In  No Seal	A0716-044G	44"	Lay-in	Grey	44.3"	45.7"	42.1"	42.9"	10.9"
	A0716-044GT	44"	Lay-in Tall Skirt	Grey	44.3"	45.7"	42.1"	42.9"	18.4"
	A0716-044LIDG	44"	Lid Only Lay-in	Grey	44.3"	--	--	--	--

Seal Options	Model Number	Size	Style	Rim/Lid Color	Lid Dia. "A"	Overall Dia. "B"	Clear Hole I.D. "C"	Skirt I.D. "D"	Overall Ht. "E"
Cam-Lock  Seal Water-resistant	A0716-044CG	44"	Cam-Lock	Grey	44.3"	45.7"	42.1"	42.9"	10.9"
	A0716-044CGT	44"	Cam-Lock Tall Skirt	Grey	44.3"	45.7"	42.1"	42.9"	18.4"
	A0716-044CLG	44"	Lid Only Cam-Lock	Grey	44.3"	--	--	--	--

Replacement Parts

Model No.	Description
496379	Composite Rim Seal, Water-Resistant
494781K	Cam-Lock Assembly
496378	HDPE Skirt Extension Kit

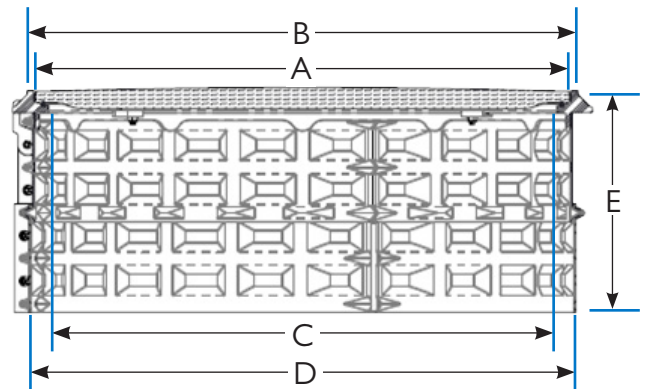

Shown above is the stacked, double-height skirt.

Composite Manholes

A0716 Composite Manholes

Stainless Steel Assemblies

All composite manholes are available with Type 304 stainless steel rim and skirt.

Model Number	Style	Lid Dia. A	Overall Dia. B	Clear Hole C	Skirt ID D	Overall Ht. E
A0716-018SS	18" Lay-in	17.0"	17.6"	15.6"	15.9"	13.0"
A0716-039SS	39" Lay-in	39.5"	40.4"	37.8"	38.3"	13.0"
A0716-042SS	42" Lay-in	43.8"	44.6"	42.0"	42.5"	13.0"
A0716-044SS	44" Lay-in	44.3"	45.1"	42.5"	43.1"	13.0"

For cam-lock versions, add a "C" to the end of the part number.

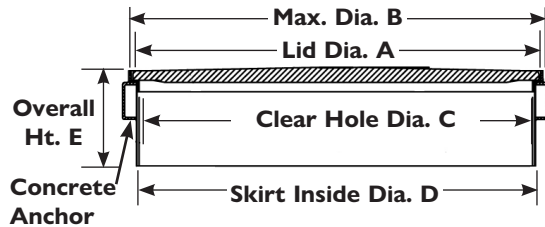

A0716-018SS
18" Lay-in



A0716-039SSC
39" Cam-Lock

Wedding Cake Assemblies

Installs over containment sump

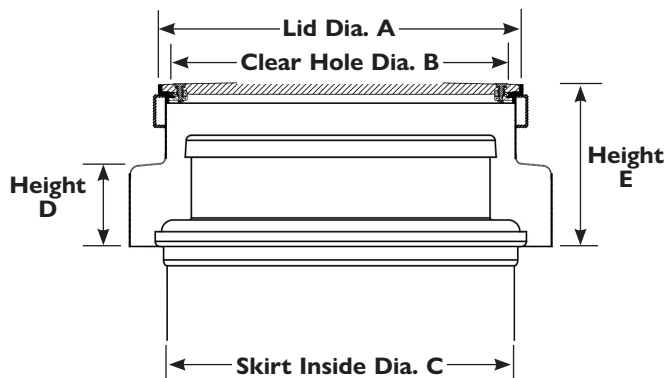

Model Number	Style	Lid Dim. A	Clear Hole Dim. B	Skirt ID C	Height D	Height E
A0716-042CW	42" Cam Lock	43.75"	41.57"	52"	10.10"	21.25"
A0716-042CDW*	42" Cam Lock w/D-Seal	43.75"	41.38"	52"	10.10"	22.16"
A0716-044CW	44" Cam Lock	44.25"	42.25"	52"	10.10"	21.25"
A0716-044CDW*	44" Cam Lock w/D-Seal	44.25"	42.06"	52"	10.10"	22.16"

*Includes water-tight D-Seal

Add "S" suffix for stainless steel rim and skirt

Custom Skirt heights available

Composite Manholes

A0716 Composite Manholes

Drop-In Replacement Lids

Emco drop-in replacement lids are available in Black or Grey.



Environ

Model No.	Lid Dia.	Emco P/N
WTM	39.5"	A0716-039E
WTM-4511	45.5"	A0716-044E
WTM-4521	45.5"	A0716-044E

Franklin FLEX-ING™

Model No.	Lid Dia.	Emco P/N
14U-3810C	39.0"	A0716-039LIDF
14U-39R	39.5"	A0716-039LID
14U-39MOR	38.9"	A0716-039M
14U-4210C	43.8"	A0716-042LID
14U-44R	44.3"	A0716-044LID
14U-44MOR2	44.9"	A0716-044M

Franklin SAFE-LITE

Model No.	Lid Dia.	Emco P/N
78144806	39.5"	A0716-039LID
78144506	45.5"	A0716-044LID
78144506	45.5"	A0716-044LIDG



Morrison Brothers

Model No.	Lid Dia.	Emco P/N
318L-3812ACC	39.5"	A0716-039M
318L-4412ACC	45.5"	A0716-044M**
318L-4412ACC	45.5"	A0716-044MA*

OPW Conquistador™

Model No.	Lid Dia.	Emco P/N
E00618	39.5"	A0716-039LID
E00626	44.3"	A0716-044LID
E00626	44.3"	A0716-044LIDG

OPW Matador

Model No.	Lid Dia.	Emco P/N
212529	38.12"	A0716-039LIDM
212518	42.62"	A0716-042LIDM

Emco	Color	Emco 3/8" Steel	Lid OD	OPW	Franklin	Flexing	Morrison	Environ
A0716-020LID	Black		20.00"	101BG				
A0716-039E	Black		39.50"					WTM-3911
A0716-039LID	Black	A0717-039LID	39.50"	E00618	781-448-06	14U-39R		
A0716-039LIDM	Black		38.12"	212529				
A0716-039LIDF	Black		39.00"			14U-3810C		
A0716-039M	Black	A0717-039M	38.75"			14U-39MOR	318L-3812ACC	
A0716-042LID	Black	A0717-042LID	43.75"			14U-4210C		
A0716-042LIDM	Black		42.62"					
A0716-044LID	Black	A0717-044LID	44.25"	E00626	781-445-06	14U-44R		
A0716-044LIDG	Grey		44.25"	E00626	781-445-06	14U-44R		
A0716-044E	Black		45.625"					WTM-4511, WTM-4521
* A0716-044MA	Black		44.50"				318L-4412ACC	
** A0716-044M	Black	A0717-044M	44.50"			14U-44MOR2	318L-4412ACC	

*Custom Morrison Replacement Lid Only: Lid OD (44 1/2") x Lid Thickness (2 1/2")

**Custom Morrison Replacement Lid Only: Lid OD (44 1/2") x Lid Thickness (2")

Standard Manholes

A0717 Round Manholes

The Emco Wheaton A0717 multi-purpose manhole provides access to all types of underground storage or containment vessels and meets AASHTO H20 wheel loading.

- Open throat design for easy access
- Optional galvanized steel or polyethylene skirt (8" & 12")
- Bolt-down units have water-resistant lids
- Cam-lock units with D-Seal have water-tight lids
- Built-in handle (18")
- Custom skirt heights available on all models

24" - 48" Models

- Diamond plate steel lid
- Hot rolled steel skirt
- Concrete anchors
- T-bar frame
- Recessed handle
- Available in lay-in, bolt-down and cam-lock versions



A0717-036B



A0717-018B

A0717-188

A0717-022B

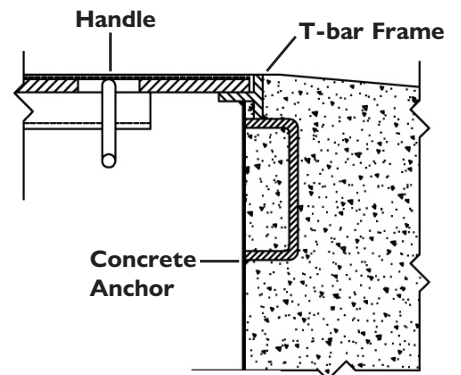

Seal Options (24" - 48" Models)

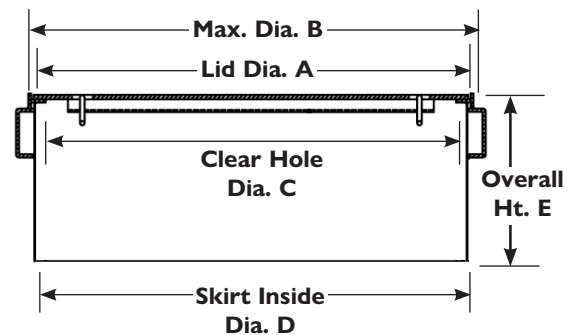
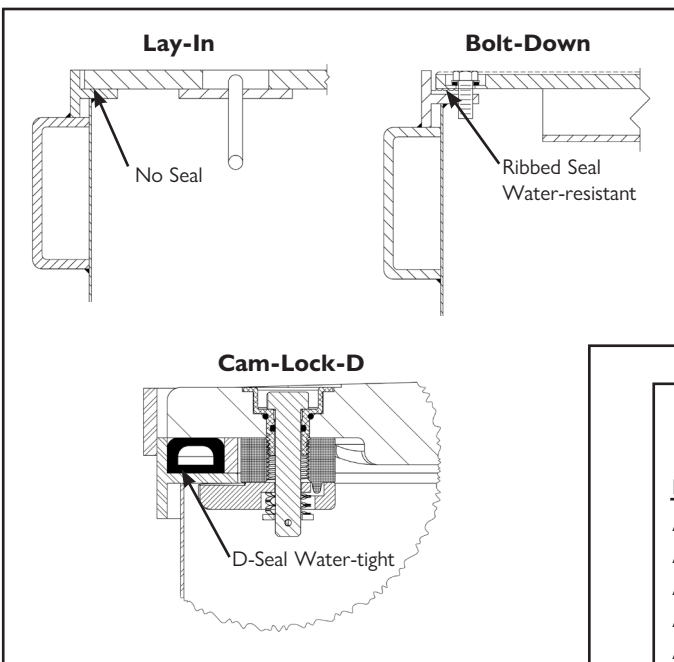

3/8" Steel Drop-In Replacement Lids For Competitors' Manholes

Emco	OPW	Franklin	Flexing	Morrison
A0717-039LID	E00618	781-448-06		
A0717-039M				318L-3812ACC
A0717-042LID			14U-4210C	
A0717-044LID	E00626	781-445-06		
A0717-044M				318L-4412ACC

Standard Manholes

A0717 Round Manholes

	Model Number	Pallet Qty.	Style	Skirt	Lid	Lid Dia. A	Max. Dia. B	Clear Hole Dia. C	Skirt I.D. D	Overall Ht. E	Lbs.
8"	A0717-008	48	Lay-in	Poly	Cast Iron	9.0"	9.9"	8.0"	8.1"	12.0"	10.6
	A0717-108	64	Lay-in	Galv. Steel	Cast Iron	9.0"	9.9"	8.0"	8.4"	10.0"	12.6
12"	* A0717-022	27	Lay-in	Poly	Cast Iron	12.4"	13.8"	11.3"	12.0"	12.0"	18.0
	A0717-022B	27	Bolt-down	Poly	Cast Iron	12.4"	13.8"	9.4"	12.0"	12.0"	23.0
	* A0717-122	27	Lay-in	Galv. Steel	Cast Iron	12.4"	13.8"	11.6"	12.0"	10.0"	25.3
	A0717-122B	27	Bolt-down	Galv. Steel	Cast Iron	12.4"	13.8"	9.4"	12.0"	10.0"	28.8
	A0717-122FG	27	Lay-in, w/finger hole	Galv. Steel	Cast Iron	12.4"	13.8"	11.6"	12.0"	10.0"	26.0
	567177		Lid Only		Cast Iron	12.4"					10.0
18"	* A0717-018	15	Lay-in	Galv. Steel	Cast Iron	17.0"	17.8"	16.0"	17.0"	10.0"	51.0
	A0717-018A	10	Lay-in	Galv. Steel	Cast Iron	17.0"	17.8"	16.0"	17.0"	18.0"	58.1
	A0717-018B	15	Bolt-down	Galv. Steel	Cast Iron	17.0"	17.8"	14.1"	17.0"	10.0"	56.3
	567715X		Lid Only Lay-in**		Cast Iron	17.3"					26.5
	570893L		Lid Only Lay-in***		Cast Iron	17.0"					22.9
	570893B		Lid Only Bolt-down		Cast Iron	17.0"					
24"	A0717-024		Lay-in	Steel	3/8" Steel	23.6"	24.5"	21.4"	23.0"	10.0"	88.0
	A0717-024A		Lay-in	Steel	3/8" Steel	23.6"	24.5"	21.4"	23.0"	18.0"	98.0
	A0717-024CD		Cam Lock w/D-Seal	Steel	3/8" Steel	23.6"	24.5"	21.6"	23.0"	10.0"	90.0
	A0717-024CDA		Cam Lock w/D-Seal	Steel	3/8" Steel	23.6"	24.5"	21.6"	23.0"	19.0"	101.0
	A0717-124		Bolt-down	Steel	3/8" Steel	23.6"	24.5"	21.4"	23.0"	10.0"	90.0
	A0717-124B		Bolt-down	Steel	3/8" Steel	23.6"	24.5"	21.4"	23.0"	19.0"	100.0
	A0717-030		Lay-in	Steel	3/8" Steel	29.6"	30.5"	27.5"	28.5"	10.0"	125.0
30"	A0717-030B		Bolt-down	Steel	3/8" Steel	29.6"	30.5"	27.5"	28.5"	13.0"	127.0
	A0717-030CD		Cam Lock w/D-Seal	Steel	3/8" Steel	29.6"	30.5"	27.5"	28.5"	13.0"	128.0
	A0717-036		Lay-in	Steel	1/2" Steel	35.6"	36.3"	33.6"	35.0"	10.0"	206.0
36"	A0717-036B		Bolt-down	Steel	1/2" Steel	35.6"	36.3"	33.6"	35.0"	13.0"	208.0
	* A0717-136		Lay-in	Steel	3/8" Steel	35.6"	36.3"	33.6"	35.0"	10.0"	189.0
	A0717-136B		Bolt-down	Steel	3/8" Steel	35.6"	36.3"	33.6"	35.0"	13.0"	191.0
37"	A0717-037CD		Cam Lock w/D-Seal	Steel	3/8" Steel	37.0"	37.9"	35.0"	35.0"	13.0"	203.0
	A0717-037CDA		Cam Lock w/D-Seal	Steel	3/8" Steel	37.0"	37.9"	35.0"	35.0"	19.0"	218.0
38"	A0717-038		Lay-in	Steel	1/2" Steel	39.6"	40.5"	37.6"	39.0"	10.0"	270.0
	A0717-038B		Bolt-down	Steel	1/2" Steel	39.6"	40.5"	37.6"	39.0"	13.0"	272.0
	* A0717-038C		Lay-in	Steel	3/8" Steel	39.6"	40.5"	37.6"	39.0"	10.0"	225.0
	A0717-038CB		Bolt-down	Steel	3/8" Steel	39.6"	40.5"	37.6"	39.0"	13.0"	227.0
42"	A0717-042A		Lay-in	Steel	1/2" Steel	44.1"	45.0"	42.1"	43.5"	10.0"	324.0
	A0717-042AB		Lay-in	Steel	1/2" Steel	44.1"	45.0"	42.1"	43.5"	19.0"	341.5
	A0717-042B		Bolt-down	Steel	1/2" Steel	44.1"	45.0"	42.1"	43.5"	13.0"	326.0
	A0717-042CD		Cam Lock w/D-Seal	Steel	3/8" Steel	44.1"	45.0"	42.1"	43.5"	13.0"	327.0
	A0717-042CDA		Cam Lock w/D-Seal	Steel	3/8" Steel	44.1"	45.0"	42.1"	43.5"	18.0"	344.5
	A0717-042D		Lay-in	Steel	3/8" Steel	44.1"	45.0"	42.1"	43.5"	10.0"	268.5
48"	A0717-048		Lay-in	Steel	1/2" Steel	47.1"	48.0"	45.1"	46.5"	10.0"	362.0
	A0717-048CD		Cam Lock w/D-Seal	Steel	3/8" Steel	47.1"	48.0"	45.1"	46.5"	13.0"	365.0
	A0717-148		Lay-in	Steel	3/8" Steel	47.1"	48.0"	45.1"	46.5"	10.0"	301.0

*Most common variant

**Old Style

***>05/14

Standard Manholes

A0717 Square Manholes and Vaults



A0717-724VW



Lift Assist

A0717-736VWL

The Emco Wheaton A0717 square manhole provides ease of access to a variety of tank hardware and monitoring equipment.

All Square Manholes

- 3/8" heavy duty diamond plate lid
- 16 gauge steel skirt
- Meets AASHTO H20 wheel loading

Locking Vault Manholes

- Double hinged lid opens and folds back to 180°
- Lock-access lid permanently fastened with anti-theft chain; secured with single pinned bolt

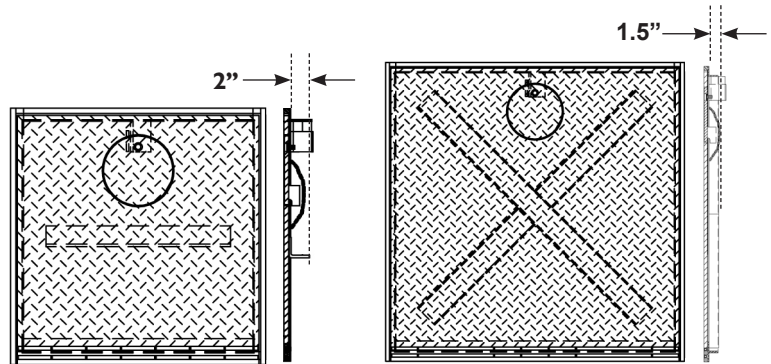

The 24" and 30" vaults are reinforced with 2"x2"x1/4" steel angle

The 36" and 48" vaults are reinforced with cross bracing of 3" structural steel channel

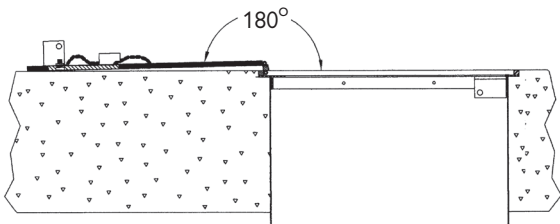

Round Vaults Available

See following page for part numbers

Standard Manholes

A0717 Square Manholes and Vaults

Size	Model No.	Style	Overall Height	Lid Lbs.	Total Lbs.
12"	*A0717-712VW	Locking Vault Water-resistant	11.6"	18	38.1
	A0717-712VWA	Locking Vault Water-resistant	24.6"	18	46.3
	A0717-712VWB	Locking Vault Water-resistant	18.6"	18	42.5
18"	A0717-718	Lay-in	9.6"	36	56.3
	*A0717-718ABW	Bolt-down Water-resistant	18.6"	36	73.3
	A0717-718BWA	Bolt-down Water-resistant	24.6"	36	87.3
	*A0717-718VW	Locking Vault Water-resistant	18.6"	36	76.8
	A0717-718VWA	Locking Vault Water-resistant	24.6"	36	96.0
	A0717-718VWL	Locking Vault Lift Assist Water-resistant	18.6"	36	77.3
24"	A0717-724	Lay-in	9.6"	65	88.4
	A0717-724A	Lay-in	24.6"	65	112.0
	A0717-724ABW	Bolt-down Water-resistant	24.6"	65	119.8
	A0717-724BBW	Bolt-down Water-resistant w/Handle	24.6"	65	122.2
	A0717-724BW	Bolt-down Water-resistant w/Handle	9.6"	65	107.2
	A0717-724E	Lay-in w/Handle	12.6"	65	117.0
	A0717-724V	Locking Vault	24.6"	65	116.5
	*A0717-724VW	Locking Vault Water-resistant	24.6"	65	121.5
	A0717-724VWB	Locking Vault Water-resistant	10.6"	65	116.5
	A0717-724VWC	Vault Bolt-down Water-resistant w/Handle	24.6"	65	126.4
	A0717-724VWE	Locking Vault Water-resistant	18.6"	65	117.0
	*A0717-724VWL	Locking Vault Lift Assist Water-resistant	24.6"	68	120.9
30"	A0717-730VW	Locking Vault Water-resistant	24.6"	123	200.0
	A0717-730VWL	Locking Vault Lift Assist Water-resistant	24.6"	123	200.0
36"	A0717-736VW	Locking Vault Water-resistant	36.6"	165	307.4
	A0717-736VWA	Locking Vault Water-resistant 36x24x24	24.6"	165	265.0
	A0717-736VWAL	Locking Vault Lift Assist WR 36x24x24	24.6"	165	270.0
	A0717-736VWL	Locking Vault Lift Assist Water-resistant	36.6"	171	287.0
	A0717-736VWLA	Locking Vault Lift Assist Water-resistant	24.6"	171	268.5
48"	A0717-748VWL	Locking Vault Lift Assist Water-resistant	48.6"	165	550.0
	A0717-748VWLA	Locking Vault Lift Assist Water-resistant	24.6"	165	470.0
	A0717-748VWLF	Locking Vault Lift Assist WR 24x24x48	24.6"	171	320.0

*Most common variant

Custom sizes available upon request

V = Hinged; B = Bolt-down; W = Water-resistant; L = Lift Assist Lid

495320 Standard Spring Assembly Kit for 24" Vaults

495779 24" Safety Latch Assembly for 24" Vaults

A0717 Round Vaults

Size	Model No.	Style	Overall Height	Lid Lbs.	Total Lbs.
18"	A0717-818VWA	Round Vault, Bolt-down	9.6"	27.4	45.1
	A0717-818VW	Round Vault, Bolt-down	18.6"	27.4	50.4
	A0717-818VWD	Round Vault, Bolt-down	24.6"	27.4	55.7
24"	A0717-824VWA	Round Vault, Bolt-down	18.6"	52.36	95.1
	A0717-824VW	Round Vault, Bolt-down	24.6"	52.36	102.7

Monitoring Well Manholes

A0721 Monitoring Well Manholes

All Emco Wheaton Monitoring Well Manholes incorporate cast-in identification triangles in accordance with API recommendations and meet AASHTO H20 wheel loading.

- Painted ductile iron lid and rim
- Optional galvanized steel or polyethylene skirt
- Bolt-down units have water-tight lids
- Custom skirt heights available
- Heavy Duty (16 gauge hot rolled carbon steel) skirts available. 100% welded skirt and seam. To order, replace the first digit of the variant number with a 2.



Built-in side handle on 18" models - one hand opening and positioning



■ City of LA Approval BR800075
A0721-001ID, A0721-008CEID
A0721-101ID, A0721-108ID



ID tag available on all models; large enough for all new regulatory requirements. To order, add "ID" to the end of the part number.

A0726-050ID ID Tag Kit
Includes tags and rivets for 50 units

A0720 Locking Cap & Collar

The Emco Wheaton A0720 locking cap and collar is used to limit access and seal monitoring wells and can be threaded or solvent welded onto a 4" PVC monitoring well pipe. It displays the monitoring well designation and includes a padlock. The cap and collar are both made of durable ABS plastic.

Model No.	Description	Pipe Size	Lbs.
A0720-001	Locking Cap and Collar, With Lock/Key	4"	1.3
A0720-001NL	Locking Cap and Collar, Without Lock/Key	4"	1.0

Replacement Parts

564029 Lock/Key Set A0720

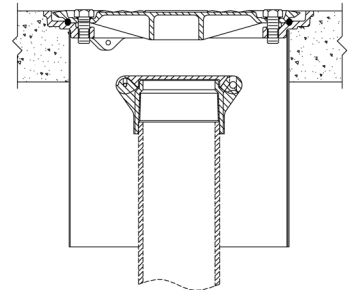

Monitoring Well Manholes

A0721 Monitoring Well Manholes

Size	Model No.	Pallet Qty.	Lid Type	Skirt Style	Color	Overall Height	Clear Hole ID	Max. Dia.	Lbs.
5"	* A0721-105	100	Bolt-down	Galv. Steel	Black	8.5"	3.8"	6.0"	5.7
	* A0721-106	125	Bolt-down	Galv. Steel	Black	7.5"	4.5"	6.7"	6.3
6"	A0721-106A	100	Bolt-down	Galv. Steel	Black	9.5"	4.5"	6.7"	6.4
	* A0721-008	48	Bolt-down	Poly	Black	12.3"	6.0"	9.9"	11.7
8"	A0721-008CE	48	BD, Large Bolts	Poly	White	12.3"	6.0"	9.9"	11.1
	* A0721-108	48	Bolt-down	Galv. Steel	Black	12.0"	6.0"	9.9"	13.7
	A0721-108W	48	Bolt-down	Galv. Steel	White	12.0"	6.0"	9.9"	13.7
	* A0721-188	64	Bolt-down	Galv. Steel	Black	8.0"	6.0"	9.9"	12.8
	* A0721-188L	64	Lay-in	Galv. Steel	Black	8.0"	7.8"	9.9"	11.9
	*** A0721-208W****	48	BD, Welded w/Lugs	HD Steel	White	12.5"	6.0"	9.9"	12.7
	A0721-308	64	BD, 3 Bolts	Galv. Steel	White	7.7"	6.4"	9.4"	12.8
	A0721-308A	48	BD, 3 Bolts	Galv. Steel	White	11.7"	6.4"	9.4"	13.7
	** A0722-008	48	Bolt-down	Poly	Black	12.3"	6.0"	9.9"	12.4
	* A0721-001	27	Bolt-down	Poly	White	12.0"	9.4"	15.1"	23.0
12"	A0721-001CC	27	BD w/Rebar Tabs	Poly	White	12.0"	9.4"	15.1"	23.1
	A0721-001L	27	Lay-in	Poly	Black	12.0"	11.2"	13.8"	22.8
	* A0721-101	27	Bolt-down	Galv. Steel	White	12.0"	9.4"	15.1"	28.8
	A0721-101A	18	Bolt-down	Galv. Steel	White	18.0"	9.4"	15.1"	31.0
	A0721-101L	27	Lay-in	Steel	Black	12.0"	11.2"	13.8"	28.6
	A0721-119	18	Bolt-down	Galv. Steel	White	19.0"	9.4"	15.1"	36.3
	A0721-128	36	Bolt-down	Poly	White	8.1"	9.4"	15.1"	21.9
	A0721-128A	36	Bolt-down	Galv. Steel	White	8.0"	9.4"	15.1"	23.6
	** A0722-001	27	Bolt-down	Poly	White	12.0"	9.4"	15.1"	24.3
	18"	* A0721-018	15	Bolt-down	Steel	Black	12.3"	13.8"	18.4"
A0721-118		10	Bolt-down	Steel	Black	18.0"	13.8"	18.4"	69.5

* Most common variant
 ** Includes locking cap & collar

*** Heavy duty
 **** Compliant with Wisconsin Administrative Code, Groundwater Monitoring Well Requirements, NR141.13, Subsection 4b

Lid Replacement Parts

Part No.	Lid	Description	Lbs.	Part No.	Lid	Description	Lbs.
569883	5"	Lid Ductile Bolt-down	3.0	566419	8"	O-ring for 3/8" Bolt	
569885	5"	Lid Gasket		566334	8"	O-ring for 5/8" Bolt	
494263	5"	Bolt, 3/8" x 0.5"		568715	8"	Neoprene Washer for 3/8" Bolt	
568692	6"	Lid Ductile Bolt-down	2.4	569723	12"	Lid Ductile Lay-in	11.6
568820	6"	Lid Gasket		563980	12"	Lid Ductile Bolt-down	11.0
568662	6"	Bolt, 5/16" x 0.75"		563593	12"	Lid Gasket	
571700	7"	Lid Ductile Bolt-down	3.3	496254	12"	Bolt & O-ring, 5/8" x 1.25", 15/16" Hex	
571702	7"	Lid Gasket		566334	12"	O-ring for 5/8" Bolt	
494261	7"	Bolt & Neoprene Washer, 3/8" x 1"		567712	18"	Lid Ductile Bolt-down	28.8
569285	8"	Lid Ductile Lay-in	5.1	567995	18"	Lid Gasket	
569106	8"	Lid Ductile Bolt-down	5.1	494262	18"	Bolt & O-ring, 5/8" x 1.75", 15/16" Hex	
567150	8"	Lid Ductile Bolt-down, A0721-008CE	5.1	494375	18"	Bolt & O-ring, 3/8" x 2"	
570767	8"	Lid Ductile Bolt-down, A0721-308 (3 bolt)	5.1	566419	18"	O-ring for 3/8" Bolt	
567146	8"	Lid Gasket		566334	18"	O-ring for 5/8" Bolt	
494260	8"	Bolt & O-ring, 5/8" x 1", 15/16" Hex, A0721-008CE		568715	18"	Neoprene Washer for 3/8" Bolt	
494261	8"	Bolt & Neoprene Washer, 3/8" x 1"					

Well Protectors

A0727 Square Well Protectors

Available in 4", 6", & 8" Sizes

- Raintight Cap - one piece die cast aluminum cap is powdered coated for corrosion resistance and painted with contrasting black triangle
- Riveted Construction - cap overlaps hinge pins, preventing vandalism
- Lockable
- Top Kit - complete cap assembly for bare tubing
- Optimized height - clears tallest well plug

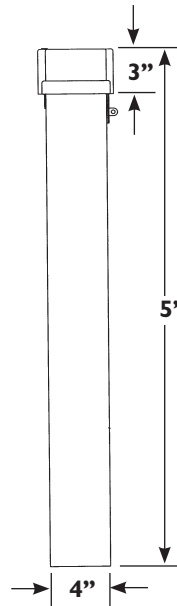

Model No.	Description	Material	Lbs.
A0727-004A	4"x4"x5' Square Well Protector	Aluminum	12.0
A0727-004S	4"x4"x5' Square Well Protector	Steel	23.0
A0727-006A	6"x6"x5' Square Well Protector	Aluminum	21.8
A0727-008A	8"x8"x5' Square Well Protector	Aluminum	34.0
A0727-008AA	8"x8"x5' Square Well Protector	Anodized Aluminum	34.0

Custom lengths available upon request

Stainless Steel Hinges
Open 150°



Replacement Top Kits

Model No.	Description	Material	Lbs.
A0727-004K	Top Kit for Bare Tubing	Aluminum	1.60
A0727-006K	Top Kit for Bare Tubing	Aluminum	1.93
A0727-008K	Top Kit for Bare Tubing	Aluminum	2.97

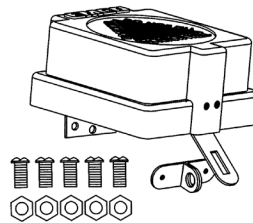

Phase I Enhanced Vapor Recovery System

Executive Order VR-105

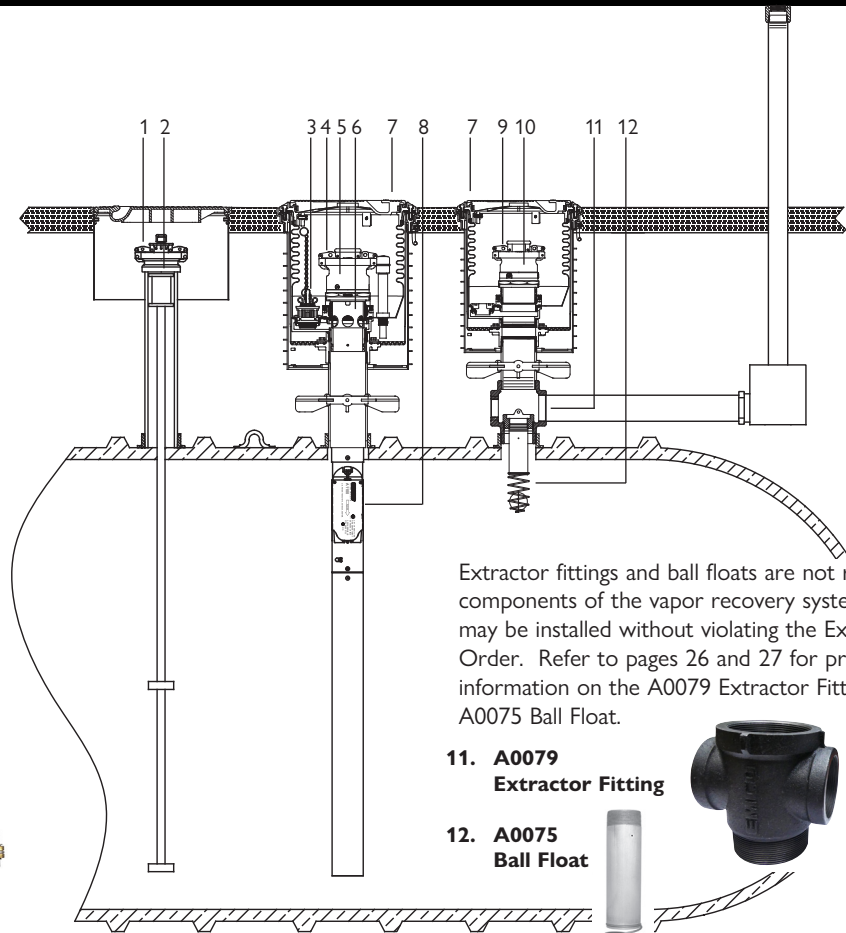

Extractor fittings and ball floats are not required components of the vapor recovery system, but may be installed without violating the Executive Order. Refer to pages 26 and 27 for product information on the A0079 Extractor Fitting and A0075 Ball Float.

1. **A0097**
Fill Cap for
Tank Probe
(Refer to p. 11)



- A0097-010A**
Tank Probe Cap
& Adapter
(Refer to p. 11)



2. **A0030-014**
ATG Adapter
A0030-014F
ATG Adapter for
INCON Tank Probe
(Refer to p. 11)



3. **494118**
Drain Valve



4. **A0097**
Fill Cap
(Refer to p. 7)



5. **A0030-124S**
Fill Swivel Adapter
(Refer to p. 6)



6. **494096**
Riser Seal



7. **A1004EVR**
Spill Containment
(Refer to p. 90)



8. **A1100EVR**
OPV Assembly
(Refer to p. 93)



9. **A0099**
Vapor Cap
(Refer to p. 9)



10. **A0076-124S**
Vapor Swivel
Adapter
(Refer to p. 8)



Optional Items:

- A0097-004LP**
Low Profile
Fill Cap
(Refer to p. 7)



- A0099-004LP**
Low Profile
Vapor Cap
(Refer to p. 9)



A0020EVR Drop Tube



Phase I Enhanced Vapor Recovery System

A1004EVR Direct Bury Spill Containment

Replaceable

- Nominal capacity of 5 or 15 US gallons
- 4-inch NPT thread connection, requires no face seal adapter
- Heavy duty, snow plow resistant, ductile iron rim and lid, exceeds DOT H-20 loading specifications
- Lid w/triple wiper seal
- Replaceable from grade level HDPE primary and secondary bellows
- Drain valve w/ filter option
- EZ-Gage or float sensor for interstitial monitoring of secondary containment
- HDPE or galvanized gravel guard
- HDPE gravel pan

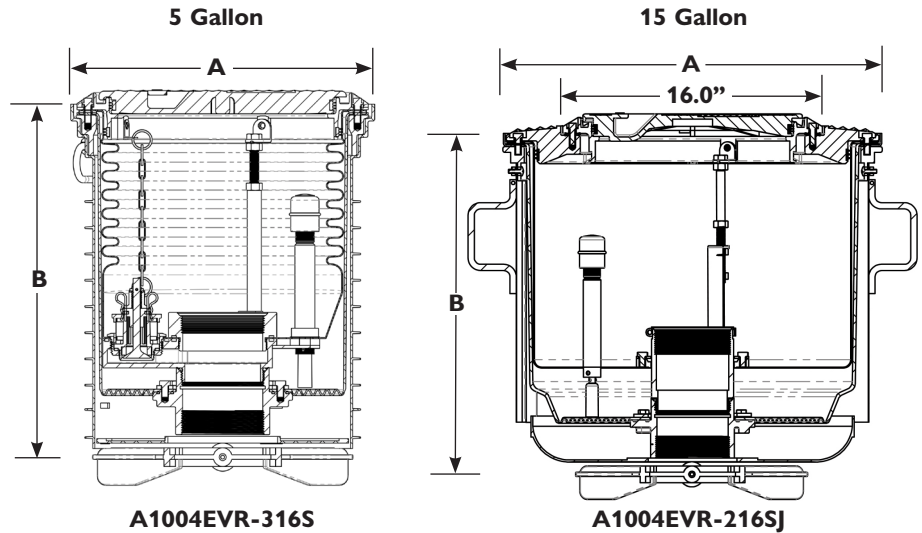

Model No.	Description	Overall Dia. A	Installed Ht. B	Lid Dia.	Lid Lbs.	Total Lbs.	Drain Type
A1004EVR-316A	SW, 5 gal, 16" center	16.0"	15.0"	13.2"	15.9	66.0	Drain Valve
A1004EVR-317A	SW, 5 gal, 16" center	16.0"	15.0"	13.2"	15.9	63.0	None
A1004EVR-317AS	SW, 5 gal, 16" center SST Primary; Poly Secondary	16.0"	15.0"	13.2"	15.9	63.0	None
A1004EVR-216A	SW, 15 gal, SST	22.6"	18.9"	13.2"	15.9	126.0	None
A1004EVR-316S	DW, 5 gal, 16" center	16.0"	17.1"	13.2"	15.9	84.0	Drain Valve
A1004EVR-317S	DW, 5 gal, 16" center	16.0"	17.1"	13.2"	15.9	79.9	None
A1004EVR-317SS	DW, 5 gal, 16" center SST Primary; Poly Secondary	16.0"	17.1"	13.2"	15.9	79.9	None
A1004EVR-216SJ	DW, 15 gal, SST Primary, Poly Secondary	22.6"	19.0"	13.2"	15.9	151.0	None

Non-Replaceable

- Nominal capacity of 5 US gallons
- 4-inch NPT thread connection, requires no face seal adapter
- Heavy duty, snow plow resistant, ductile iron rim and lid, exceeds DOT H-20 loading specifications
- Lid w/triple wiper seal
- Non-replaceable from grade level HDPE primary bellows
- Drain valve w/filter or plug option
- HDPE gravel guard
- HDPE gravel pan

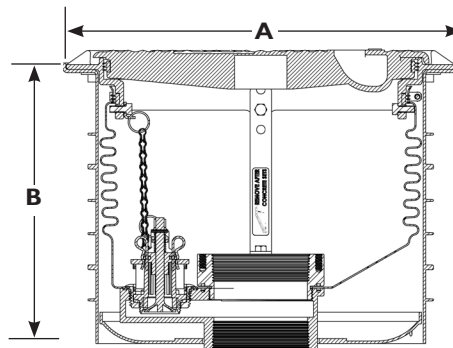

Model No.	Description	Overall Dia. A	Installed Ht. B	Lid Dia.	Lid Lbs.	Total Lbs.	Drain Type
A1004EVR-010	Slimline, SW, 5 gal	17.6"	13.6"	15.3"	20.0	58.5	Drain Valve
A1004EVR-011	Slimline, SW, 5 gal	17.6"	13.6"	15.3"	20.0	57.9	Drain Plug

Phase I Enhanced Vapor Recovery System

A1004EVR Spill Containment Replacement Parts

Replacement Kits

Model No.	Description	Lbs.
A1004EVR-210		
5 Gal Poly		
494360EVR	Primary Replacement Kit (EVR-210A, SW/Drain)	64.0
494466EVR	Primary Replacement Kit (EVR-211A, SW/Drain Plug)	68.5
494350EVR	Primary Replacement Kit (EVR-210S, DW/Drain)	71.4
494350EVRs	Primary Replacement Kit (EVR-210S, DW/Drain) For old style A1004-210 (see photo at right)	71.4
494467EVR	Primary Replacement Kit (EVR-211S, DW/No Drain)	67.7
494467EVRs	Primary Replacement Kit (EVR-211S, DW/No Drain) For old style A1004-210 (see photo at right)	67.7
A1004EVR-216		
15 Gal EVR SST/Poly		
494660EVR-S	Primary & Secondary Replacement Kit	
495880	Kit Spacer 3/4", A1004EVR-215/216	
569989	Flat Rim Gasket Ø15"	
570069	Flat Rim Gasket Ø22"	
573728	Rim Adapter Triple Wiper Seal	
A1004EVR-316		
5 Gal Poly, 16" Center		
494797EVR	Primary Replacement Kit (EVR-316A, SW/Drain)	
494798EVR	Primary Replacement Kit (EVR-317A, SW/No Drain)	
494794EVR	Primary Replacement Kit (EVR-316S, DW/Drain)	53.5
494795EVR	Primary Replacement Kit (EVR-317S, DW/No Drain)	36.5

Cast iron lid included with all A1004EVR Replacement Kits. To order with a composite lid, add a "C" to the end of the part number.

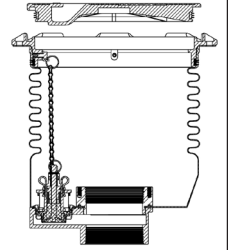

Old Style A1004-210
No flanges or bolts

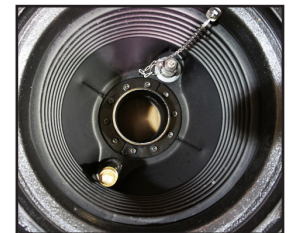

New Style A1004-210
Flanges and bolts included



Lids

Model No.	Description
Lids, 5 Gallon	
A1004-210LID	Lid & Seal, cast iron
A1004-210LID-C	Lid & Seal, composite
571815	Triple Wiper Seal
A1004-316CLID	Lid & Seal, cast iron
A1004-316LID	Lid & Seal, composite
570012	Triple Wiper Seal
Lids, 15 Gallon	
494554	Lid & Seal, cast iron
569227	Triple Wiper Seal for 17.3" (494554) lid
569989	Primary rim flat gasket 16"
570012	16" lid Triple Wiper Seal
573728	Triple Wiper Seal for 22" to 16" rim adapter
Drain	
494118	Drain Valve Kit w/Filter



A1004-210LID
Cast Iron



A1004-210LID-C
Composite



494554



A1004-316CLID
Cast Iron



A1004-316LID
Composite



Phase I Enhanced Vapor Recovery System

A1004EVR Multi-Port Spill Containment

Guide Specification:

- 42-inch steel diamond plate lid with 16-inch tank bung spacing
Optional diamond plate lid in light weight aluminum
- 6 cam-locks and dual lid handles for easy lock-down and removal
- 8-inch observation port w/ water tight seals
- All mounting bolts non-corrosive stainless steel
- Manhole rim channel w/ D-seal for water tightness integrity between lid and rim
- Manhole available w/ 12-inch or 18-inch galvanized skirt
- Nominal spill container capacity of 5 US gallons
- Cast iron spill container base w/4-inch NPT thread connection
Requires no face seal adapter
- Powder coated, heavy duty, cast iron lid and ductile iron plow ring, exceeds DOT H-20 loading
Optional lid in composite material
- Lid w/ triple wiper seal
- HDPE primary spill container bellows
- Drain valve w/ filter or plug option
- Compatible with most water shrouds and boot kits

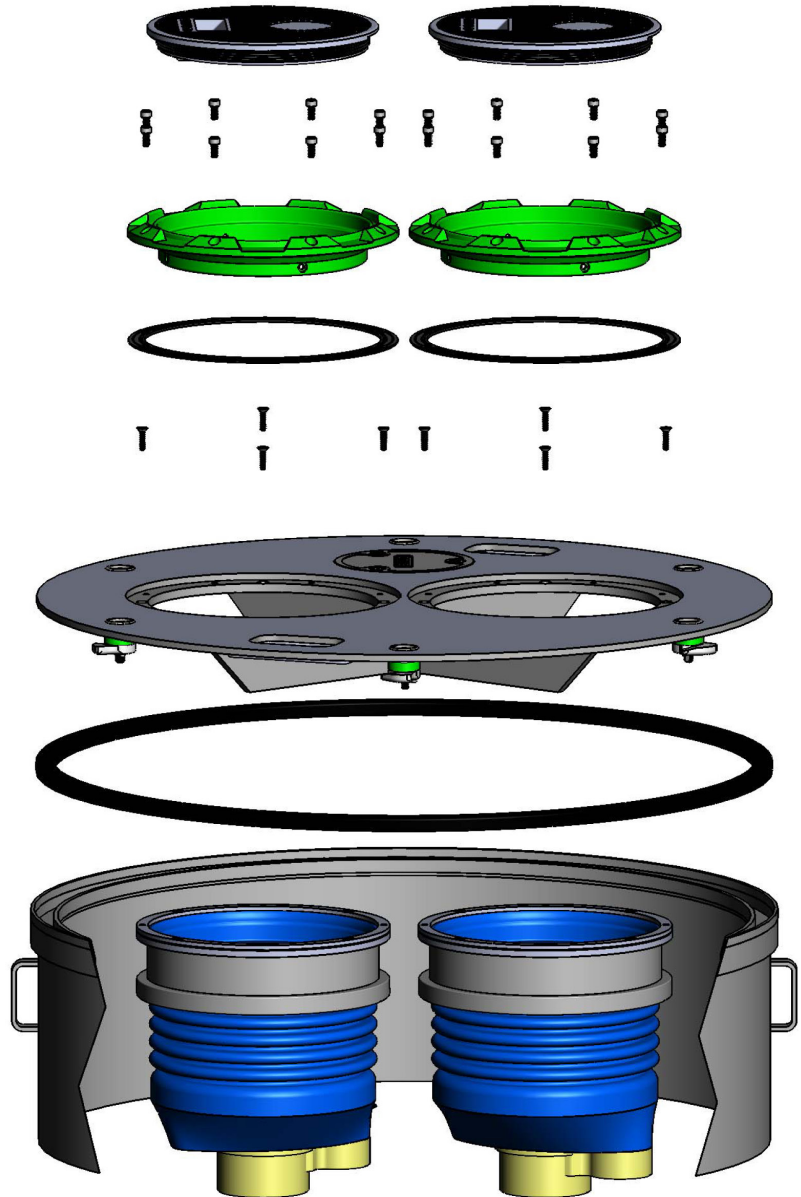

- CARB Phase I EVR Executive Order VR-105
- Florida DEP EQ-741

Model No.	Description	Spill Container #1	Drain Type	Spill Container #2	Drain Type
A1004EVR-2421D1A	42" Multi-Port MH, 8" Observation Port 12" Skirt, Gasoline	SW, 5 gal	Drain Valve	SW, 5 gal	No Drain
A1004EVR-242101A	42" Multi-Port MH, 8" Observation Port 12" Skirt, Gasoline	SW, 5 gal	No Drain	SW, 5 gal	No Drain
A1004EVR-2421D0A	42" Multi-Port MH, 8" Observation Port 12" Skirt, Diesel	SW, 5 gal	Drain Valve	None	N/A
A1004EVR-242100A	42" Multi-Port MH, 8" Observation Port 12" Skirt, Diesel	SW, 5 gal	No Drain	None	N/A

Custom configurations are available upon request

Phase I Enhanced Vapor Recovery System

A1100EVR Overfill Prevention Valve

- 1 Upper drop tube to valve body factory welded
Optional: Upper drop tube and collar factory anodized to prevent corrosion
- 2 Bleed valve drains fuel delivery hose after 95% shut-off
- 3 Diverter fins protect flapper valve during routine “tank stick” gauging
- 4 Top and bottom floats contained in protective sleeve to insure damage-free installation and removal from tank fill riser
- 5 Die cast aluminum valve body design provides the highest delivery flow rate
- 6 Spring loaded reset function opens flapper valve and allows for immediate “tank stick” gauging
- 7 Flapper valve provides positive fuel shut-off at 95% total storage tank capacity
- 8 External field test port allows for manual routine testing of flapper valve
- 9 Valve body to male coupling factory welded
- 10 Female coupling to lower drop tube factory welded
 - Materials and seals are compatible with up to E25 ethanol blend gasoline and B20 biodiesel blends
 - Factory tested for operability and vapor tightness integrity
 - The A1100EVR OPV is not recommended for underground storage tanks under 6.5 ft in diameter

No Epoxy!

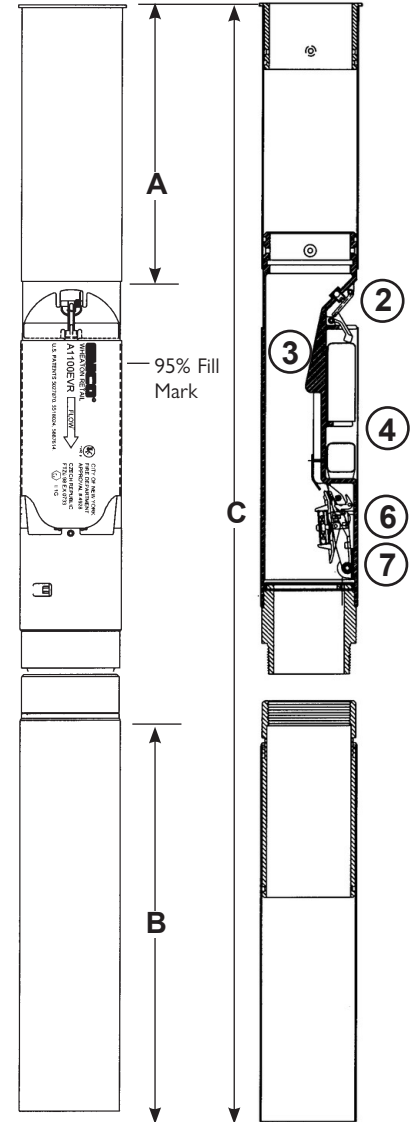
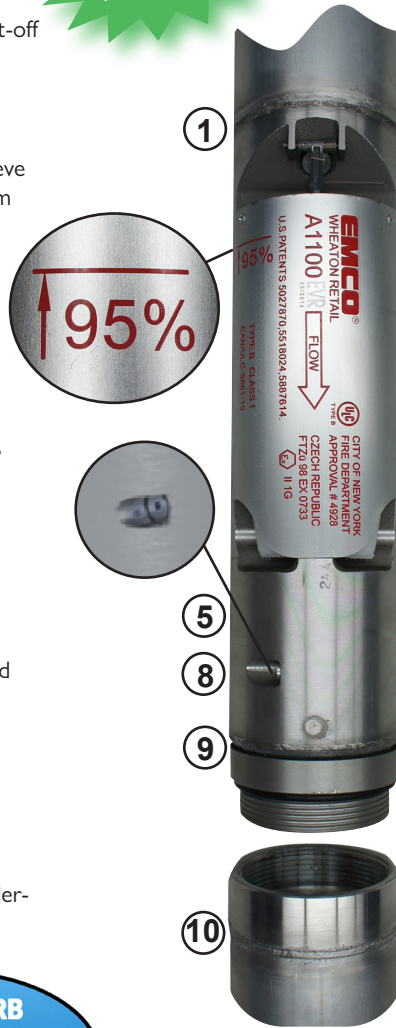

Material

Body: Aluminum
Floats: HDPE
Seals: Viton®

Viton® is a registered trademark of The Chemours Company.



Model No.	Anodized Model No.	Upper Length A	Lower Length B	Overall Length C	Max. Burial Depth	Nominal Tank Dia.	Lbs.
A1100EVR-055	A1100EVR-055CF	70"	82"	167" (14.0')	6.0'	8'	25.2
A1100EVR-056	A1100EVR-056CF	82"	94"	191" (16.0')	7.0'	10'	27.2
A1100EVR-057	A1100EVR-057CF	82"	120"	217" (18.2')	6.8'	12'	30.3
A1100EVR-058	A1100EVR-058CF	120"	120"	255" (21.3')	10.0'	12'	31.0

Maximum burial depth assumes 95% shut-off and 6" clearance between top of drop tube and inside bottom of containment manhole lid.

Replacement Parts:

- 493734E Riser Collar Kit
569461 Drop tube O-ring



566675
Drill Fixture

Phase I Enhanced Vapor Recovery System

A0020EVR Drop Tube

The A0020EVR Drop Tube fits directly into the tank riser pipe to permit tight fill submerged filling with reduced turbulence and minimal vapor loss. 4" diameter.

Model No.	Length	Lbs.
Rolled Edge Collar		
A0020EVR-004	12'	13.0
A0020EVR-005	15'	16.1
A0020EVR-007	17'	18.2
A0020EVR-008	14'	14.0
Heavy Duty Collar		
A0020EVRC-004	12'	13.7
A0020EVRC-005	15'	16.8
A0020EVRC-007	17'	18.9
A0020EVRC-008	14'	14.7



Standard Rolled Edge



Heavy Duty Collar

Replacement Parts

569461 Drop Tube O-ring

Material

Tube: Aluminum

Seals: Viton®

Viton® is a registered trademark of The Chemours Company.



EVR Installation and Maintenance Tools

All tool bits are fully interchangeable with A0081-001D Drive Shaft and A0081-001X Cross Bar

Also available:
 A0081-001A Extension
 A0081-001Q Quick Release Pin



A0081-001B Adapter Wrench Bit

Installation and removal of:
 • Models A0030-014, A0030-124S & A0076-124S Adapters
 • Model 494096 Riser Seal



A0081-001HB Spill Containment Wrench Bit

Installation and removal of:
 • Model A1004EVR Series Spill Containers (Multiport or Direct Bury)



A0081-001LB Riser Seal Wrench Bit

Installation and removal of:
 • Model 494096 Riser Seal Center Insert
 • Models A0030-024 & A0030-024A Adapters



494240 Swivel Adapter Torque Test Wrench

Verification of static torque for:
 • Models A0030-124S and A0076-124S per CARB test procedure TP-201.1B



493820 Drain Valve Wrench

Installation and removal of:
 • Drain Valve Part Number 494118



566675 A1100EVR Collar Drill Fixture

Drilling of collar mounting holes:
 • Model A1100EVR Overfill Valve



Balance Phase II Enhanced Vapor Recovery

CARB Executive Orders

VR-203, VR-204, VR-207, VR-208, VR-501



99.5%
Vapor Collection
Efficient



A4005EVR Balance Vapor Recovery Nozzle





A4119EVR-020 Coaxial SafeBreak® Valve Non-Reconnectable

A4119EVR-020RC Coaxial SafeBreak® Valve Reconnectable



Classified by UL to
UL 2586, Valves for Flammable Fluids
CARB Approved Mix & Match with VST
CARB Approved for UST and AST
Installations
Nozzle & Breakaway Core Credit
Program, refer to page 104

CARB EVR approved for use with:

Pressure Management Options			ISD System Options	
				Franklin Fueling INCON
Veeder-Root Polisher Canister	Healy Clean Air Separator	Hirt VCS-100 Oxidizer		Veeder-Root TLS-350

Balance Phase II EVR Components

A4005EVR Balance Vapor Recovery Nozzle

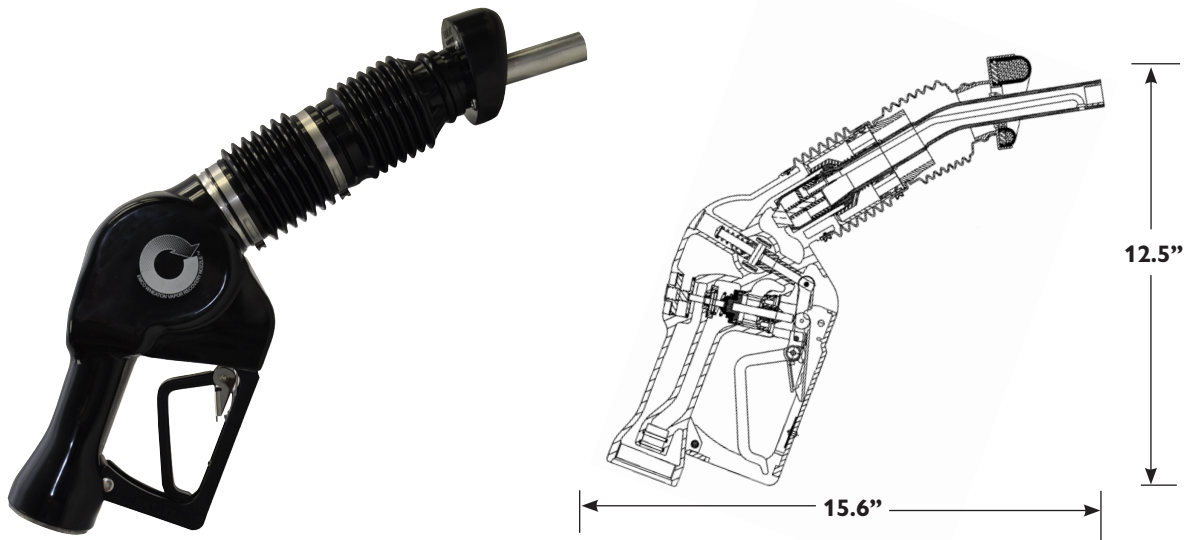

The A4005EVR Nozzle is designed for use with Balance Phase II Vapor Recovery Systems. Complies with the California Air Resources Board CARB Enhanced Vapor Recovery Program EVR Certification Procedures CP-201.

Material

Body & Spout: Aluminum
Lever & Guard: Thermoplastic
Seals: Nitrile & Viton®
Scuff Guard: Vinyl

Viton® is a registered trademark of The Chemours Company.



- CARB EVR Executive Orders VR-203, VR-204, VR-207, VR-208, VR-501
- CARB Pre-EVR Mix & Match Approval Letter #09-10/ Advisory #408
- California State Fire Marshall GVRC 005:007:025
- California Division of Measurement Standards 3211(d)-09
- UL Listing MH1460 Classified to UL 2586

Model No.	Description	Lbs.
A4005EVR-052	New Unleaded	4.5

Refer to page 96 for Phase II EVR repair and replacement kits and tools.

A4005EVR Flow Data (kPa)

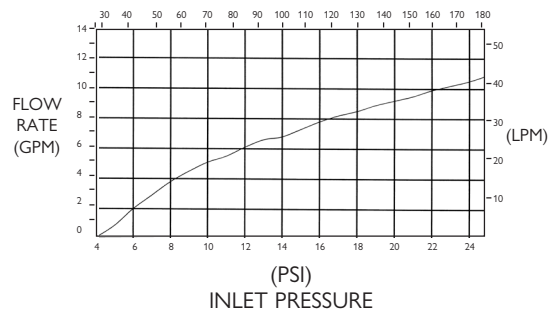

A4110EVR Coaxial Hose Swivel

The A4110EVR 45° hose swivel provides a full range of movement to minimizing kinking and twisting of the coaxial curb hose during routine vehicle refueling. Complies with CARB CP-201 Enhanced Vapor Recovery EVR Program.

Model	Description	Lbs.
A4110EVR-001	Coaxial Hose Swivel	1.3

Repair Kits & Replacement Parts

494748EVR Fuel Path O-ring Kit
494749EVR Vapor Path O-ring Kit

Material

Body: Cast Aluminum
Snap ring: Plated Steel
Swivel nut: Chrome Plated Brass

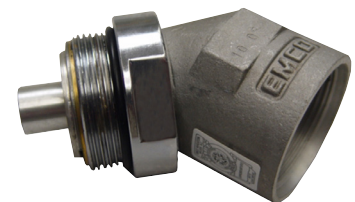
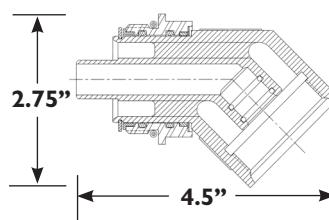

- CARB EVR Executive Orders VR-203, VR-204, VR-207, VR-208, VR-501
- UL Listed MH6036

Balance Phase II EVR Components

A4119EVR Coaxial SafeBreak® Valve

Reconnectable

The Model A4119EVR-020RC Coaxial SafeBreak® Valve is a shear pin style field reconnectable component designed for use with Balance Phase II Vapor Recovery systems. Complies with California Air Resources Board CARB Enhanced Vapor Recovery EVR Certification Procedures CP-201. A dual poppet design seals off both the fuel and vapor paths upon separation due to customer related “drive-off” events, eliminating fuel spillage and vapor emissions, and minimizing damage to the dispenser unit.

Model	Description	Lbs.
A4119EVR-020RC	Reconnectable Coaxial SafeBreak® Valve	1.3
A4119EVR-020RCS	Factory Serviced Reconnectable Coaxial SafeBreak® Valve	1.3
572909	Clamp Tool	1.9
495989	Clamp Tool Plate Kit	1.0

Repair Kits & Replacement Parts

494748EVR	Fuel Path O-ring Kit
495820	Shear Pin Kit
495843	Snap Cover Kit
495866	Suff Guard Kit

Material

Body: Aluminum
O-rings: Buna-N
Protective Cover: Santoprene

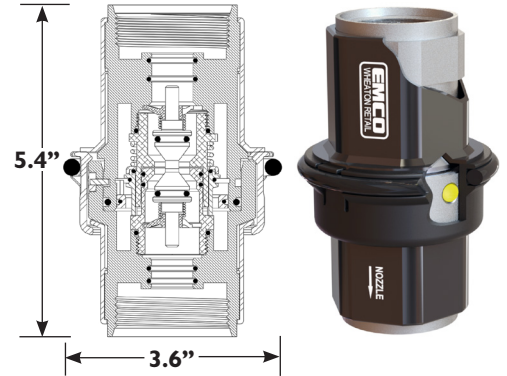

- CARB EVR Executive Orders VR-203, VR-204, VR-207, VR-208, VR-501
UL Listed MH17833

Non-reconnectable

The A4119EVR-020 Coaxial SafeBreak Valve is a shear pin style non-reconnectable component designed for use with Balance Phase II Vapor Recovery Systems. Complies with California Air Resources Board CARB Enhanced Vapor Recovery EVR Certification Procedures CP-201. A dual poppet design seals off both the fuel and vapor paths upon separation due to customer related “drive-off” events, eliminating fuel spillage and vapor emissions, and minimizing damage to the dispenser unit.

Model No.	Description	Lbs.
A4119EVR-020	Coaxial Shear Pin	1.6

Repair Kits & Replacement Parts

494748EVR	Fuel Path O-ring Kit
-----------	----------------------

Material

Body: Aluminum
O-rings: Buna-N
Protective Cover: Vinyl

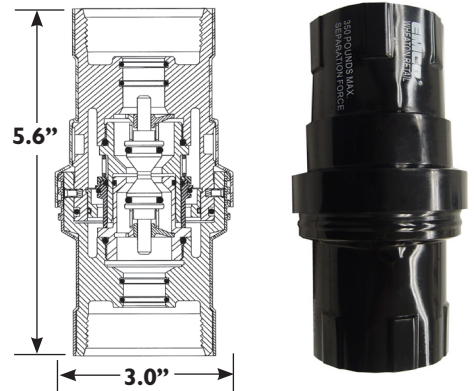

- CARB EVR Executive Orders VR-203, VR-204, VR-207, VR-208, VR-501
CARB Pre-EVR Mix & Match Approval Letter #09-10/Advisory #408
UL Listed MH17833

A0063EVR Vapor Shear Valve

The A0063EVR vapor shear valve installs on the phase II vapor riser below the dispenser to eliminate the escape of vapors in the event of a collision to the dispenser. The double poppet valve incorporates a 1.5” female NPT connection to the underground piping and a 1” female NPT connection to dispenser piping. The valve incorporates a 3/8” test port. Mounting Kit is included. Approved for use with all CARB certified pre-EVR and EVR phase II vapor recovery systems.

Model No.	Description	Inlet	Outlet	Lbs.
A0063EVR-024	1 1/2” Double Poppet	Female	Female	4.0

Material

Body: Cast Iron
Spring: Stainless Steel
Seal: Viton®

Viton® is a registered trademark of The Chemours Company.

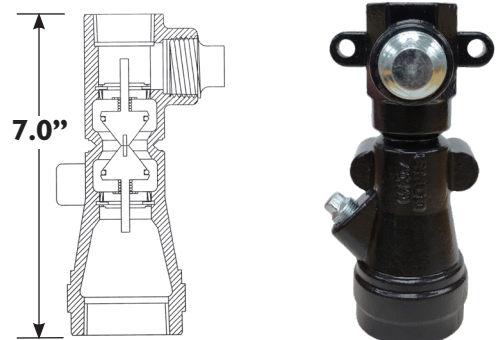

- UL Listed MH10206

Balance Phase II EVR Components

Repair Kits & Replacement Parts



492775EVR
Bellows & Boot Face Kit



492834EVR
Spout Kit



492776EVR
Boot Face Kit



494150EVR
Latch Kit

A4005EVR Nozzle Repair Kits

Kit No.	Description	Lbs.
492775EVR	Bellows & Boot Face Kit	0.4
492776EVR	Boot Face Kit	0.2
492834EVR	Spout Kit	0.6
494150EVR	Latch Kit	0.5
494748EVR	Fuel Path O-ring Kit	
494750EVR	Bellows Band Clamp Kit	0.1
A0557EVR-002	Scuff Guard, Black	0.4

- CARB EVR Executive Orders VR-203, VR-204, VR-207, VR-208, VR-501
UL Listed MH036



A4110EVR Hose Swivel Repair Kits

Kit No.	Description
494748EVR	Fuel Path O-ring Kit
494749EVR	Vapor Path O-ring Kit

A4119EVR SafeBreak® Repair Kits

Kit No.	Description
494748EVR	Fuel Path O-ring Kit

A4005EVR Nozzle Required Service Tools

- 494655EVR Balance Phase II EVR Service Kit**
Includes all Phase II installation and maintenance tools and sturdy, canvas tool bag
- 494635EVR Spout Plug**
Use to conduct CARB test procedure TP-201.6 or TP-201.6C Liquid Removal Test
- 494652EVR Bellows Band Clamp Crimp Tool**
Use to install and crimp the A4005EVR nozzle bellows band clamps
- 494653EVR Lever Guard Rivet Installation Tool**
Use to install the A4005EVR nozzle lever guard rivets
- 494654EVR Lever Guard Rivet Removal Tool**
Use to remove the A4005EVR nozzle lever guard rivets
- 494712EVR Bellows Retainer Plate Tool**
Use to secure the A4005EVR nozzle bellows during installation of the bellows band clamps
- 494761EVR Balance Nozzle Adapter**
Use to test and verify the accuracy of the ISD vapor flow meter
- 494771EVR Surrogate Spout Assembly**
Use to conduct a leak tightness integrity test on the ISD vapor flow meter test assembly



NOZZLES

Balance Phase II Pre-EVR Components

A4005 Vapor Recovery Nozzle w/ Vapor Valve

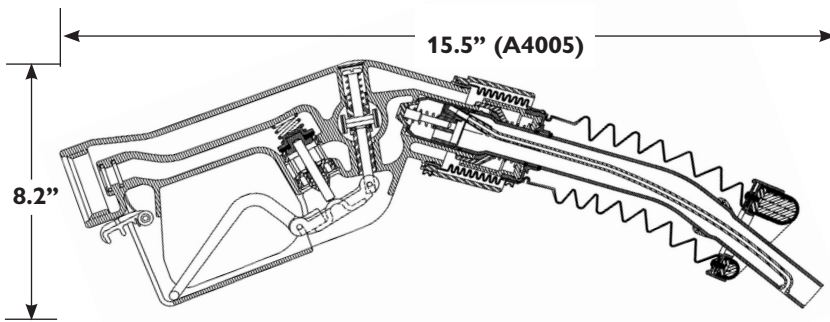

- CARB Executive Orders G-70-17-AD, G-70-52-AM, G-70-199-AJ
- UL Listed MH1460 Classified to UL 2586
- Approved by the N.Y. Department of Environmental Conservation and the Oregon Department of Environmental Quality

The A4005 Vantage has proven itself as the balance vapor recovery nozzle of choice. Developed to be user friendly, the A4005 utilizes the most up-to-date vapor recovery technology available.

The A4005 offers the same lightweight and streamlined design advantages characteristic of the A4000 series product line. A low restriction vapor valve is built into the A4005 so it does not require an external vapor valve. This nozzle includes the no-seal, no-flow interlock mechanism and automatic shutoff for reliable, safe operation. It also has an internal pressure shutoff to detect vapor blockage.

Material

Body & Spout: Aluminum
 Lever: Thermoplastic
 Lever Guard: Aluminum
 Seals: Nitrile & Viton®
 Scuff Guard: Vinyl

Viton® is a registered trademark of The Chemours Company.

Model No.	Description	Lbs.
A4005-002	New Unleaded	4.6
A4005-004	Rebuilt Unleaded	4.6
A4005-002E	New Unleaded E85	4.6

The above part numbers include the standard glossy black scuff guard.

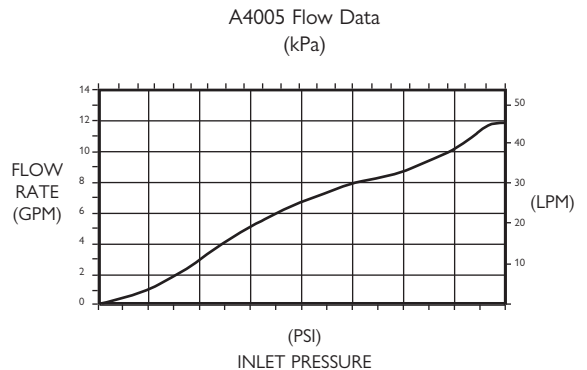

Balance System

A4005 Balance Nozzle

A4005 Replacement Parts

Kit No.	Description	Lbs.
493040	Spout Kit - Unleaded	2.0
493042	Boot Face Kit.2	
493047	Clamp & Cover Kit	0.4
493062	Latch Kit	0.1
493781	Boot & Face Kit	0.7
493846	Front End Kit - Spout/Boot	1.5
563834	Clamp 52.2 mm	0.2
566965	Clamp 66.0 mm	0.3
565048	Scuff Guard, Black Emco Logo	0.4

A4015 Replacement Parts

Kit No.	Description	Lbs.
493042	Boot Face Kit	0.2
493047	Clamp & Cover Kit	0.4
493062	Latch Kit	0.1
493398	Spout Kit - Unleaded	0.6
493400	Boot & Face Kit	0.5
493847	Front End Kit - Spout/Boot	0.9
563834	Clamp 52.2 mm	0.2
566965	Clamp 66.0 mm	0.3
565048	Scuff Guard, Black Emco Logo	0.4

Nozzle & Breakaway Core Credit Policy

Models Allowed For Core Credit	Return for Credit Against the Following
Nozzles A4005 A4015 A4005EVR Competitor EVR Nozzle	Rebuilt A4005 Rebuilt A4005 New A4005EVR New A4005EVR
Breakaways A4119EVR-020 or A4119EVR-020RC A4119EVR-020 or A4119EVR-020RC Competitor EVR Breakaway	New A4119EVR-020RC New A4119EVR-020 New A4119EVR-020

*Contact customer service for core credit values

Credits: All nozzle and breakaway cores must be returned within 90 days of invoice to be eligible for credit.

Cores with cracked bodies, stripped threads or damaged in any way that limits their ability to be rebuilt will not be accepted for credit.

Nozzle cores returned without a front end assembly (spout, bellows and boot face) or any other part will be subject to a 50% core credit reduction.

Breakaway cores must be returned as a complete unit (both male and female halves) to be eligible for a core credit.

Invoicing: Nozzle and breakaway models allowed for core credit will be invoiced at list price less your distributor discount. Acceptable cores will be credited against those invoices.

Freight: Inbound freight charges for nozzle and breakaway cores returned for credit must be prepaid by the distributor.

Core Bank: Nozzle and breakaway cores may be sent to Emco in anticipation of future purchases. Emco will store all cores in the distributor's account for a maximum time period of 18-months from date received. All cores stored longer than 18 months will be discarded and no credit given.

Nozzle Replacement Parts

A0500 Splash Guard

The A0500 Splash Guard is constructed of TPR and is for use on all conventional nozzles.

Model No.	Color	Lbs.
A0500-002	Black	0.1
A0500-062	Green	0.1
A0500-064	Yellow	0.1

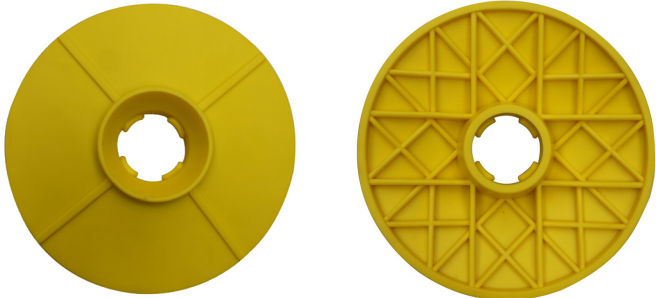

Additional colors are available upon request; please contact our Customer Service Department at 800-234-4394.

DISPENSER
ACCESSORIES

SafeBreaks®

Standard Shear Pin

A2119 3/4" SafeBreak®

A3019 1" SafeBreak®

The Emco Wheaton A2119 and A3019 Standard SafeBreaks® have an economical shear pin design with 3/4" (A2119) and 1" (A3019) connections for standard applications. The double poppets seal both hoses upon separation.

Material

Body: Aluminum
 O-rings & Seals: Buna-N & Viton®
 Protective Cover: Plastic
 Viton® is a registered trademark of The Chemours Company

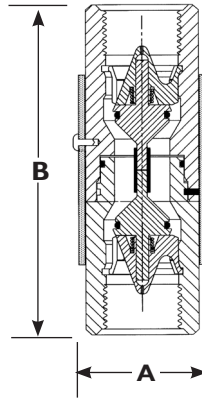

- UL Listed MH17833
 ETL 536786
 ATEX (A2119-002) FTZU07ATEX0240

Model No.	Description	A	B	Lbs.
A2119-002	3/4" Shear Pin NPT	1.6"	4.2"	0.4
A2119-003	3/4" Shear Pin BSPP	1.6"	4.2"	0.4
A3019-001	1" Shear Pin NPT	2.0"	6.3"	1.0
A3019-003	1" Shear Pin BSPP	2.0"	6.3"	1.0

Standard Reconnect

A2219 3/4" SafeBreak®

A3219 1" SafeBreak®

The Emco Wheaton A2219 and A3219 Standard SafeBreaks® allow for immediate return to service after a drive-away, with no repair kit required. This is made possible by a unique, reconnectable design. The double poppets seal both hoses upon separation.

Material

Body: Aluminum
 O-rings & Seals: Buna-N & Viton®
 Protective Cover: Plastic
 Viton® is a registered trademark of The Chemours Company

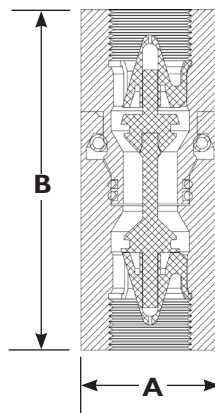

- UL Listed MH17833

Model No.	Description	A	B	Shipping Dim.	Lbs.
A2219-002	3/4" Reconnectable NPT	2.0"	4.2"	4.5" x 2" x 2"	0.8
A3219-001	1" Reconnectable NPT	2.0"	6.3"	6" x 2.25" x 2.125"	1.0
572909B	Clamp Tool	-	-	-	-

Vapor Recovery

A4119EVR Coaxial SafeBreak® Valve

Reconnectable

The Model A4119EVR-020RC Coaxial SafeBreak® Valve is a shear pin style field reconnectable component designed for use with Balance Phase II Vapor Recovery systems. Complies with California Air Resources Board CARB Enhanced Vapor Recovery EVR Certification Procedures CP-201. A dual poppet design seals off both the fuel and vapor paths upon separation due to customer related "drive-off" events, eliminating fuel spillage and vapor emissions, and minimizing damage to the dispenser unit.

Model	Description	Lbs.
A4119EVR-020RC	Reconnectable Coaxial SafeBreak® Valve	1.3
A4119EVR-020RCS	Factory Serviced Reconnectable Coaxial SafeBreak® Valve	1.3
572909	Clamp Tool	1.9
495989	Clamp Tool Plate Kit	1.0

Repair Kits & Replacement Parts

494748EVR	Fuel Path O-ring Kit
495820	Shear Pin Kit
495843	Snap Cover Kit
495866	Scuff Guard Kit

Material

Body: Aluminum
O-rings: Buna-N
Protective Cover: Santoprene

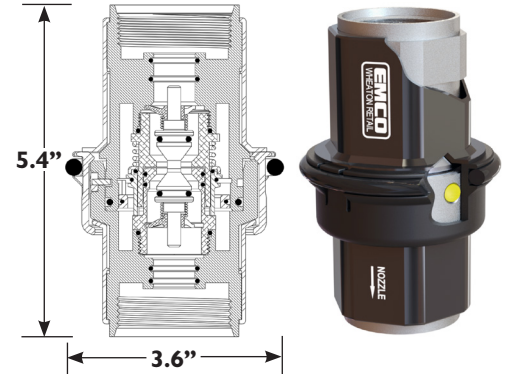

- CARB EVR Executive Orders VR-203, VR-204, VR-207, VR-208, VR-501
UL Listed MH17833

Non-reconnectable

The A4119EVR-020 Coaxial SafeBreak Valve is a shear pin style non-reconnectable component designed for use with Balance Phase II Vapor Recovery Systems. A dual poppet design seals off both the fuel and vapor paths upon separation due to customer related "drive-off" occurrences, eliminating fuel spillage, vapor emissions and minimizing damage to the dispenser unit. Complies with the California Air Resources Board CARB Enhanced Vapor Recovery Program EVR Certification Procedures CP-201.

Model No.	Description	Lbs.
A4119EVR-020	Coaxial Shear Pin	1.6

Repair Kits & Replacement Parts

494748EVR	Fuel Path O-ring Kit
-----------	----------------------

Material

Body: Aluminum
O-rings: Buna-N
Protective Cover: Vinyl

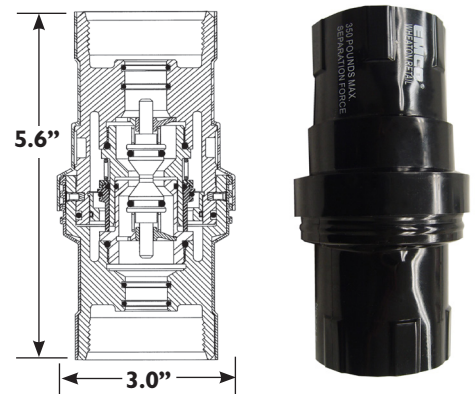

- CARB EVR Executive Orders VR-203, VR-204, VR-207, VR-208, VR-501
CARB Pre-EVR Mix & Match Approval Letter #09-10/Advisory #408
UL Listed MH17833

A4110EVR-001 Coaxial Swivel

The Emco Wheaton A4110EVR Coaxial Swivel is designed for use with balanced vapor recovery nozzles. The 45° swivel provides a full range of movement to minimizing kinking and twisting of the coaxial curb hose during routine vehicle refueling.

Material

Body: Cast Aluminum
Snap ring: Plated Steel
Swivel nut: Chrome Plated Brass

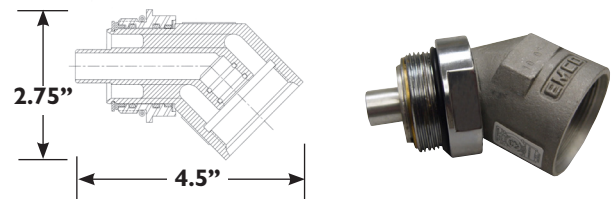

Model	Description	Lbs.
A4110EVR-001	Coaxial Swivel	1.3
494748EVR	Fuel Path O-ring Kit	
494749EVR	Vapor Path O-ring Kit	

- CARB Approval 92-14
UL Listed MH6036
Approved under Phase II EVR
Executive Orders VR-207 & VR-208

Swivels/Flow Regulators/Adapters

A0360 Swivel

The Emco Wheaton A0360 Hose Swivel features a polished die-cast aluminum body with stainless steel male fittings. Viton® o-rings provide positive sealing and compatibility with all fuels. Fluorosilicone o-rings provide excellent low temperature performance. The outlet swivel rotates 360° at the nozzle inlet to keep the nozzle in a comfortable, upright position, and prevents kinking and wear. The A0360 is designed for non-vapor recovery applications and is available with .75" or 1.0" NPT threads.

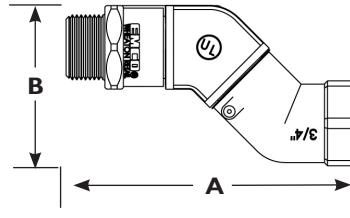

■ UL Listed MH6036

Material

Body: Aluminum
 Seal: Viton® & Fluorosilicone
 Viton® is a registered trademark of The Chemours Company.

Model No.	Hose Connection Size	Nozzle Connection Size	A	B	Lbs.
A0360-075	3/4" Female	3/4" Male	4.0"	2.2"	0.6
A0360-100	1" Female	1" Male	4.4"	2.6"	0.8

A4041, A4043 Splitters

The Emco Wheaton A4041 Splitter is used to convert a side mount dispenser which is not vapor ready, into a coaxial vapor recovery system. Coaxial port is 17/8" x 12 UN 2B thread.

For vertical island plumbing of the vapor line, order the A4041-001.
 For plumbing the vapor line through the dispenser wall, order the A4041-002.

The Emco Wheaton A4043 Splitter is for use on coaxial balance Stage II Vapor Recovery Systems. The cast aluminum body is lightweight and strong. The A4043 includes two buna o-rings for a reliable seal. Coaxial port is 17/8" x 12 UN 2B thread; fuel inlet and vapor outlet are 3/4" NPT.

Material

Body: Aluminum
 O-rings: Buna

Model	Application	Material	Lbs.
A4041-001	Island Mount	Aluminum	2.1
A4041-002	Dispenser Mount	Aluminum	1.6
A4043-001	High Mount	Aluminum	2.0

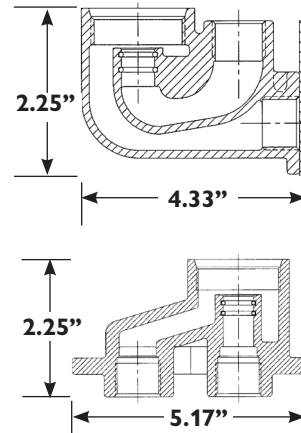

■ CARB Approval 94-26 (A4043)
 CARB E.O. G-70-52-AL (A4041)
 UL Listed MH10206

A0010 Flow Regulator

The Emco Wheaton A0010 is an in-line liquid flow regulating device calibrated to limit flow to 10 gpm, in accordance with Federal EPA requirements. The A0010 is manufactured from zinc-plated steel or aluminum with 3/4" NPT inlet/outlet threads.

Material

Body: Zinc-plated Steel
Or Aluminum

Model	Inlet	Outlet	Installation	A	B	Lbs.
A0010-003	Male	Female	Dispenser Outlet	1.4"	2.7"	1.0
A0010-010	Female	Male	Nozzle Inlet	1.1"	2.5"	0.3
A0010-011	Male	Female	Dispenser Outlet	1.1"	2.5"	0.3

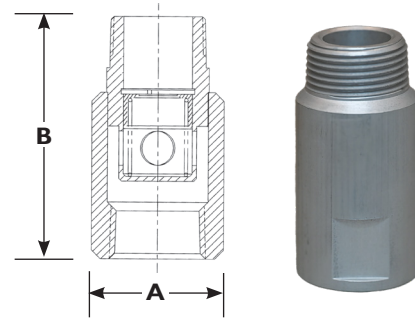

■ CARB E.O. G-70-118-AB

563639 Adapter

The Emco Wheaton 563639 Adapter allows you to retrofit a balance dispenser to use 3/4" NPT conventional hanging hardware.

The Emco Wheaton 563639AST Adapter allows you to retrofit a vacuum assist dispenser to use 3/4" NPT conventional hanging hardware. The adapter is a one-piece assembly.

Material

Body: Aluminum
O-rings: Buna

Model No.	Oz.
563639	4.0
563639AST	3.2

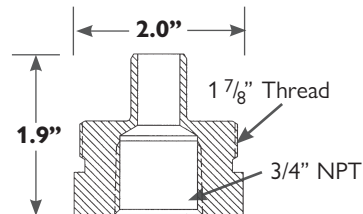

563639

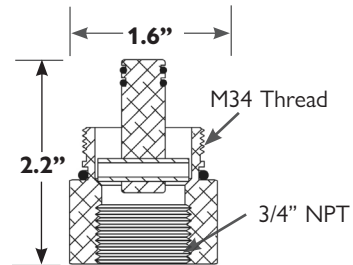

563639AST

Fuel Stop Switch Pedestal

A0729 E-Stop Switch Pedestal

The Emco Wheaton A0729-048 E-Stop Switch Pedestal is designed for emergency shut-off switches. A hole in the base provides wiring access. Welded aluminum construction. Tiger series 38 super durable powder coating in anodized silver, meets AAMA 2604 compliance providing corrosion and weather resistance in marine and other harsh environments. UV resistant for five years in Florida exposure. E-stop and sign not included.

Material

Pedestal: Powder coated aluminum

Base: Powder coated aluminum

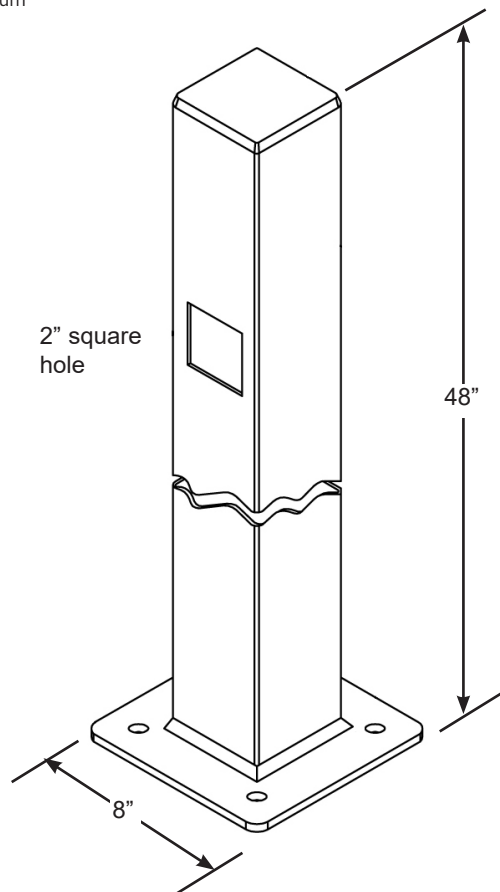

Model No.	Height	Lbs.
A0729-048	48"	11.5

Custom sizes available

CROSS
REFERENCE

Competitor Cross Reference

Emco	Description	OPW	Franklin	Universal	Morrison Bros.
Caps and Adapters					
A0030-024	FILL ADAPTER BRASS 4X4	633T-8076	778-301-02	724-4040	305L-0200A
A0030-024A	FILL ADAPTER ALUMINUM 4X4	633T-8075			
A0030-124S	FILL SWIVEL ADAPTER BRASS 4X4	61SALP-1020EVR	SWF-100-B		305SA-0200AA
A0076-002	VAPOR ADAPTER AL 4"CAMX3" RISER	1611AV-1605	300-300-01	0611V-3030	323-0100-AA
A0076-005	VAPOR ADAPTER AL 4"CAMX4" RISER	1611AV-1620	300-210-01	0611V-3040	323-0200-AA
A0076-124S	VAPOR SWIVEL ADAPTER BRASS 4X4	61VSA-1020EVR	SWV-101-B		323SA-0200-AA
A0089-001	TIGHT FILL ADAPTER COAX A0088	633TCP-3803		724CA-4040	605AL-0100-AA
A0096-001	TIGHT FILL ADAPTER COAX A0070	633TC-8090	306-300-01	724CA-4040	605AL-0100-AA
A0097-004LP	TIGHT FILL CAP 4" LOW PROFILE	634LPC-0400		731-40	
A0097-005	TIGHT FILL CAP 4"	634TT-7085EVR	777-201-01	733-40	305C-0100-ACEVR
A0097-010	TIGHT FILL CAP 4" FOR TANK PROBE	62M-0500		418TM-40	
A0099-002	VAPOR CAP 4"	1711T-7085 EVR	304-200-01	0614VC-30	323C-0100-ACEVR
A0099-004LP	VAPOR CAP 4" LOW PROFILE	1711LPC-0300		0613VC-30	

Emergency Shear Valves

A0060-002	SHEAR VALVE 1 1/2" 1 POP MALE	10BM-5825	662-410-03	521RMS-15	636M 0000 AVU
A0060-003	SHEAR VALVE 1 1/2" 1 POP FEMALE	10BF-5725	662-410-02	521RFS-15	636F 0000 AVU
A0060-022	SHEAR VALVE 1 1/2" 2 POP MALE	10BHMP-5830	662-440-03	521DP-RM-15	
A0060-023	SHEAR VALVE 1 1/2" 2 POP FEMALE	10BFP-5726	662-440-02	521DP-RF-15	
A0060-202S	SHEAR VALVE 2" 1 POP MALE	10RM-2003			636M 0200 AVU
A0060-203S	SHEAR VALVE 2" 1 POP FEMALE	10RF-2001			636F 0200 AVU
A0060-222S	SHEAR VALVE 2" 2 POP MALE	10RMP-2004			
A0060-223S	SHEAR VALVE 2" 2 POP FEMALE	10RFP-2002			
A0063EVR-024	VAPOR SHEAR VALVE 2 POP FEMALE	60VSP-1001			
492938	TOP KIT A0060 1 POP MALE	10RMT-5850	662-118-03		
492939	TOP KIT A0060 1 POP FEMALE	10RFT-5750	662-118-02		
493887	TOP KIT A0060 2 POP MALE	10RMTP-5851	662-240-01		
493888	TOP KIT A0060 2 POP FEMALE	10FTP-5701	662-242-01		

Overfill Prevention Valves

A1100-010	GUARDIAN VALVE ONLY 4"	61SO-4BYT		39-04	
A1100-065S	COAX SCREW TOGETHER 4"X13'	61SOC-4001			
A1100-067S	COAX SCREW TOGETHER 4"X18'	61SOC-4011			
A1100-085S	COAX SCREW TGTHR POPPET 4"X13'	61SOP-4002			
A1100-087S	COAX SCREW TGTHR POPPET 4"X18'	61SOP-4012			
A1100EVR-055	DP SCREW TOGETHER EVR 4"X13'	71SO-400C	708-591-901		
A1100EVR-055T	DP SCREW TOGETHER EVR 4"X13' TESTABLE	71SO-400CT	708-591-901		
A1100EVR-055TE	DP SCREW TOGETHER EVR 4"X13' TSTBL E85	71SOM-412C	708-591-921		
A1100EVR-056	DP SCREW TOGETHER EVR 4"X15'	71SO410C	708-591-902		
A1100EVR-056T	DP SCREW TOGETHER EVR 4"X15' TESTABLE	71SO-410CT	708-591-902		
A1100EVR-056TE	DP SCREW TOGETHER EVR 4"X15' TSTBL E85	71SOM-412C	708-591-922		
A1100EVR-057	DP SCREW TOGETHER EVR 4"X18'		708-592-901		
A1100EVR-057T	DP SCREW TOGETHER EVR 4"X18' TESTABLE		708-592-901		
A1100EVR-058	DP SCREW TOGETHER EVR 4"X21'	71SO-420C	708-592-902		
A1100EVR-058T	DP SCREW TOGETHER EVR 4"X21' TESTABLE	71SO-420CT	708-592-902		

Drop Tubes

A0020EVR-004	DROP TUBE ALUMINUM 4" X 12'	61T-7268		723-4012-2	419-0400-1T
A0020EVR-005	DROP TUBE ALUMINUM 4" X 15'	61T-7368		723-4015	419-0500-1T
A0020EVR-007	DROP TUBE ALUMINUM 4" X 17'	61T-7468			
A0020EVRC-004	DROP TUBE ALUMINUM 4" X 12' EVR	61T-7268	782-204-12-2		
A0020EVRC-005	DROP TUBE ALUMINUM 4" X 15' EVR	61T-7368	782-204-15-2		
A0020EVRC-007	DROP TUBE ALUMINUM 4" X 15' EVR	61T-7468			
A0088-101	DROP TUBE COAXIAL VR 4" X 12'	61TCP-3800	708-226-04-2		

Competitor Cross Reference

Emco	Description	OPW	Franklin	Universal	Morrison Bros.
Ball Floats & Extractor Fittings					
A0075-001	BALL FLOAT 2X5" 1/8 BH	53VL-0050		37-206018	317-0600AV
A0075-006	BALL FLOAT 2X6.87" 1/16 BH	53VL-0060		37-206016	
A0075-010	BALL FLOAT 2X18" 1/8 BH				317-1700-AV
A0075-013	BALL FLOAT 2X13.75" 1/8 BH			37-201218	
A0075-015	BALL FLOAT 2X15.75" 1/8 BH			37-201618	317-1500AV
A0075-017	BALL FLOAT 2X17.75" 1/8 BH				317-1700AV
A0078-015	BALL FLOAT/CAGE 2X15.75" 1/16 BH	53VML-0160	308-020-116		
A0078-021A	BALL FLOAT/CAGE 2X21" 1/16 BH	53VML-0210			
A0078-312	BALL FLOAT/CAGE 3X12" 1/16 BH	53VML-3120	308-300-12		
A0078-318	BALL FLOAT/CAGE 3X18" 1/16 BH	53VML-3180	308-300-18		
A0079-019	EXTRACTOR FTG & 2" CAGE 4X4X3X2			V421-3020	562-0100-AE
A0079-020	EXTRACTOR FTG & 2" CAGE 4X4X2X2			V421-2020	560-0100-AE
A0079-025	EXTRACTOR FTG & 2" CAGE 4X4X3X3			V421-3030	
A0079-050	EXTRACTOR FTG 4X4X2X2	233-4422		V420-2020	560-0101-MBE
A0079-051	EXTRACTOR FTG 4X4X3X2	233-4432	330-400-11	V420-3020	562-0101-MBE
A0079-052	EXTRACTOR FTG 4X4X3X3	233-4433	331-400-01	V420-3030	
A0079-119	EXTRACTOR FTG & 2" CAGE 4X4X3			V421-0030	563-0100AE
A0079-120	EXTRACTOR FTG & 2" CAGE 4X4X2			V421-0020	561-0100AE
A0079-150	EXTRACTOR FTG 4X4X2	233-4420		V420-0020	561-0101MBE
A0079-152	EXTRACTOR FTG 4X4X3	233-4430		V420-0030	563-0101MBE
A0179-002	EXTRACTOR CAGE 2"	H11930		V423	
A0279-001	EXTRACTOR CAGE TEST PLUG	233VMP-6047	391-201-01	V425	
A0560-003	WRENCH FOR BAR-STYLE CAGE 1 1/2"	89-0044	321-100-01	410W	
A0585-003	EXTRACTOR PIPE CAP BAR STYLE	116-7085		412-40	578-0100AC

Valves

A0066-020	CHECK VALVE PRES RELIEF 15-35PSI		622-200-01	212BPR-20-1535	
A0750-200	BALL VALVE	21BV-0200		213FP-20	

Suction System Components

A0732-001	UNION CHECK VALVE 1.5"		650-108-02	200A-15	331-0100AV
A0732-002	UNION CHECK VALVE & SCREEN 1.5"		650-104-02	200AS-15	331S-0100AV

Vents

		OPW	Franklin	Universal	Morrison Bros.
A0084-038	VENT P-V 3" PRES 8" VAC 2" F EPA	623V-2203			749CRB0600AV
A0084-103	VENT P-V 3" PRES 8" VAC 2" SLIP ON EPA				749CRBS600AV
A0084-204	VENT P-V 8 OZ. PRES .5 VAC 2"	523V-1100	802-303-01	46-2080	749-0100AV
A4103-002	VENT UPWARD "V" 1.5" & 2"	23-0033, -0044		45-15 / 45-20	

Competitor Cross Reference

Emco	Description	OPW	Franklin	Universal	Fairfield
Spill Containment					
A1004-316S-CM	DW 16" CENTER 5 GAL SENSOR DRAIN		705555201CI		
A1004-317S-CM	DW 16" CENTER 5 GAL SENSOR NO DRN		705555202CI		
A1004EVR-316A	SW 16" CENTER 5 GAL PP DRAIN EVR	1C-3101D	705545001CI		
A1004EVR-316S	DW 16" CENTER 5 GAL PP DRAIN EVR	1C-3112D	705555101CI		
A1004EVR-317A	SW 16" CENTER 5 GAL PP NO DRAIN EVR	1C-3101P	705545002CI		
A1004EVR-317S	DW 16" CENTER 5 GAL PP NO DRAIN EVR	1C-3112P	705555102CI		
A1004EVR-215A	SINGLE WALL 15 GAL PP DRAIN EVR	6511A-0025SC151			
A1004EVR-215S	DOUBLE WALL 15 GAL PP DRAIN EVR	1C-31512D			
A0031-175	RISER EXTENSION 4 X 4 X 1.75			1002S-40	
A0031-250	RISER EXTENSION 4 X 4 X 2.5			1002L-40	571S-0100AE

Composite Manholes		OPW	Franklin	Flexing	Morrison Bros.
A0716-039	COMPOSITE LAY-IN 39X10	39CD-PL10	781-433-13	14U-3810	318L 3800AM
A0716-039B	COMPOSITE BOLT-DOWN 39X10	39CD-WT10	781-433-12	14URT-3810	418L 3800AM
A0716-039C	COMPOSITE CAM-LOCK 39X10	39CD-RL10		14URT-3810CL	418LC3800AM
A0716-039CL	COMPOSITE CAM-LOCK LID ONLY 39"	E00714			
A0716-039LID	COMPOSITE LAY-IN LID ONLY 39"	E00618781-448-06		14U-3810C	
A0716-042	COMPOSITE LAY-IN 42X10			14U-4210	
A0716-042LID	COMPOSITE LAY-IN LID ONLY 42"			14U-4210C	
A0716-044	COMPOSITE LAY-IN 44X10	44CD-PL10	781-443-13		318L 4400AM
A0716-044B	COMPOSITE BOLT-DOWN 44X10	44CD-WT10	781-443-12		418L 4400AM
A0716-044C	COMPOSITE CAM-LOCK 44X10	44CD-RL10			418LC4400AM
A0716-044CL	COMPOSITE CAM-LOCK LID ONLY 44"	E00712			
A0716-044LID	COMPOSITE LAY-IN LID ONLY 44"	E00626781-445-06			

Standard Manholes		OPW	Franklin	Pemco	Fairfield
A0717-018	MANHOLE CI LID 18"X12" STEEL	104A-1800	781-418-12-STL	10618x10	180-12
A0717-018A	MANHOLE CI LID 18"X18" STEEL		781-418-18-STL		180-18
A0717-024	MANHOLE 3/8" STEEL LID 24"X10" STEEL	6110-2410	SR2409HD	10624X10	240 HD
A0717-030	MANHOLE 3/8" STEEL LID 30"X10" STEEL	6110-3010	SR3009HD	10630X10	300 HD-B
A0717-030B	MH 3/8" STEEL LID 30"X10" STEEL BD		SR3009WT	10730X10	300 WT
A0717-036	MANHOLE 1/2" STEEL LID 36"X10" STEEL		SR3609HD		
A0717-036B	MH 1/2" STEEL LID 36"X10" STEEL BD	6110-37WT	SR3609WT		
A0717-038	MANHOLE 1/2" STEEL LID 38"X10" STEEL		SR3809HD		
A0717-038B	MH 1/2" STEEL LID 38"X10" STEEL BD	6110-37WT	SR3809WT		
A0717-038C	MANHOLE 3/8" STEEL LID 38"X10" STEEL	6110-3710		10638X10	380HD
A0717-042A	MANHOLE 1/2" STEEL LID 42"X10" STEEL	6110-4200	SR4209HD		420HD
A0717-042D	MANHOLE 3/8" STEEL LID 42"X10" STEEL			10642X10	
A0717-048	MANHOLE 1/2" STEEL LID 48"X10" STEEL		SR4809HD	10748X10	480HD
A0717-108	MANHOLE CI LID 8"X12" STEEL			100C8X12	80-12
A0717-122	MANHOLE CI LID 12"X12" STEEL	104A-1200	781-212-12-CI	100C12X12	120-12
A0717-122B	MANHOLE STL LID 12"X12" STEEL BD			10212X12	120WT
A0717-122FG	MANHOLE CI LID 12"X12" STEEL FINGER	104FG-1200			
A0717-124	MANHOLE STEEL LID 24"X10" STEEL BD	6110-24WT		10724X10	240WT
A0717-128	MANHOLE CI LID 12"X8" STEEL			100C12X8	120 8
A0717-136	MANHOLE 3/8" STEEL LID 36"X10" STEEL	6110-3710		10636x10	360 HD
A0717-136B	MH 3/8" STEEL LID 36"X10" STEEL BD			10736X10	360 WT
A0717-148	MANHOLE 3/8" STEEL LID 48"X10" STEEL		SR4809WT	10648X10	
A0717-188	MANHOLE CI LID 8"X9" STEEL		78120808	100C8X75	80 8

Competitor Cross Reference

Emco	Description	OPW	Franklin	Pemco	Fairfield
Square Manholes and Vaults					
A0717-718	MANHOLE STEEL LID SQUARE 18"X9"				18S
A0717-724	MANHOLE STEEL LID SQUARE 24"X9"		SSQ2409	10524X24	24S
A0717-724A	MANHOLE STEEL LID SQUARE 24"X24"			10524X24X24	
A0717-724ABW	MANHOLE STEEL LID SQ 24"X24" BD WR			10524X24WT	
A0717-724V	MANHOLE LOCKING VAULT 24"X24"			104242424	
A0717-724VW	MANHOLE LOCKING VAULT 24"X24" WR			104242424WT	

Monitoring Well Manholes		Universal	Morrison Bros.	Pemco	Fairfield
A0720-001	MONITOR WELL CAP, COLLAR & LOCK	1300-40	305XA-0100 AC		
A0721-018	MONITOR WELL 18"X12" STEEL		418XAP-1200 AM	106MW18X12	108-TMW-12
A0721-101	MONITOR WELL 12"X12" STEEL	65-1212-WC	418XAP-0400 AM	10312X12	120-MW-12
A0721-106	MONITOR WELL 6"X8" STEEL			1035X6	
A0721-106A	MONITOR WELL 6"X10" STEEL			1035X12	
A0721-108	MONITOR WELL 8"X12" STEEL	65-8012-WC	418XAP-0900 AM	1038X12	80-MW-12
A0721-118	MONITOR WELL 18"X18" STEEL		418XAP-1300 AM		180-TMW-18
A0721-119	MONITOR WELL 12"X19" STEEL			10312X18	
A0721-188	MONITOR WELL 8"X9" STEEL	65-8075-WC	418XAP-0850 AM	1038X75	80-MW-8
A0721-188L	MONITOR WELL 8"X9" STEEL LAY-IN	60MW-8075		100MW8X75	
A0721-208V	MONITOR WELL 8"X12" HD STEEL		418XAW-0700 AM		

Vapor Recovery Balanced Nozzles		OPW	Husky	VST
A4005-002	N-NOZZLE-BAL-UL	11VF-XX27	005210-04	
A4005-004	R-NOZZLE-BAL-UL	11VF-XX87	005450-04	
A4015-002	N-NOZZLE-BAL-UL		005010-04	
A4015-004	R-NOZZLE-BAL-UL		005410-04	
A4005EVR-052	N-NOZZLE-BAL-UL EVR			VST-EVR-NB

Competitor Cross Reference

Emco	Description	OPW	Franklin	Husky	VST
Safebreaks					
A2119-002	SAFEBREAK 3/4" SHEAR PIN	66V-0300		2273	
A2219-002	SAFEBREAK 3/4" RECONNECTABLE	66REC-1000	697-137-01	3360	
A3019-001	SAFEBREAK 1" SHEAR PIN	66V-1300			
A3219-001	SAFEBREAK 1" RECONNECTABLE	66RB-2000	797-225-01	2276	
A4119EVR-020	SAFEBREAK COAXIAL SHEAR PIN EVR				VSTA-EVR-SBK
Swivels					
A0360-075	SWIVEL 3/4"M X 3/4"F NPT	205-7575	3DC3/4	0350	
A0360-100	SWIVEL 1"M X 1"F NPT	205-1010	3DC1X1	0087	
Splitters					
A4041-001	COAX SPLITTER ISLAND MOUNT	38CS-0380	3030101		
A4043-001	COAX SPLITTER HIGH				

Numerical Index

Model Number	Product Description	Page Number	Model Number	Product Description	Page Number
409628	Gasket Kit A0030-014, 024	6	494441A	Bottom Tube Assembly, A1100 OPV	21,23
492775EVR	Bellows & Boot Face Kit A4005EVR	102	494466EVR	Primary Rplcmnt Kit A1004EVR-211A	62,91
492776EVR	Boot Face Kit A4005EVR	102	494467EVR	Primary Rplcmnt Kit A1004EVR-211S	62,91
492834EVR	Spout Kit A4005EVR	102	494551	Drain Kit A1004EVR-210,-316	61
492938	Top Kit Male A0060-002	12	494554	Lid & Seal Kit A1004EVR-215	66,91
492939	Top Kit Female A0060-003	12	494635EVR	Spout Plug A4005EVR Service Tool	102
492963K	Fusible Link Kit A0060	12	494641	Dipstick Assembly A1004-210,-316	61
493040	Spout Kit UL A4005	102	494652EVR	Bellows Band Clamp CrimpTool A4005EVR	102
493042	Boot Face Kit A4005/A4015	102	494653EVR	Lever Guard Rivet Install Tool A4005EVR	102
493047	Clamp & Cover Kit A4005/A4015	102	494654EVR	Lever Guard Rivet RemovalTool A4005EVR	102
493062	Latch Kit A4005/A4015	102	494655EVR	Balance Phase II EVR Service Kit	102
493123	Lid & O-Ring Aluminum A1003	66	494660EVR-S	Pri.&Sec. Rplcmnt Kit A1004EVR-216S	62,91
493192	A1100 Kit, Assembly Valve to Tube	17	494697	Drain Plug Kit for 494551 Drain	61
493195	Coax Collar Kit A0070 (Not Self-Sealing)	25	494697S	Drain Plug Kit for A1005-505CEW	53
493197	Self-Sealing Coax Collar Kit A0088	25	494698	Drain Plug Kit for 493508K, 494118 Drains	61
493391	Riser Collar Kit A0020	23	494712EVR	Bellows Retainer Plate Tool A4005EVR	102
493398	Spout Kit UL A4015	102	494748EVR	Fuel Path O-Ring Kit A4005,4110,4119EVR	100,101,102
493400	Boot & Face Kit A4015	102	494749EVR	Vapor Path O-Ring Kit A4110EVR	100,102
493436	Remote Fill Cage Kit	16,17	494750EVR	Bellows Band Clamp Kit A4005EVR	102
493508K	Pull/Push Drain Assembly A1004	61	494761EVR	Balance Nozzle Adapter A4005EVR	102
493584	Boot Only Kit A4015	104	494771EVR	Surrogate Spout Assembly A4005EVR	102
493734A	Riser Collar A1100 Dual Point Modular Anodized	18	494794EVR	Primary Rplcmnt Kit A1004EVR-316S	62,91
493734E	Riser Collar A1100 Dual Pnt Modular Anodized E85	18,93	494795EVR	Primary Rplcmnt Kit A1004EVR-317S	62,91
493734S	Riser Collar A1100 Dual Point	17	494797EVR	Primary Rplcmnt Kit A1004EVR-316A	62,91
493780	Boot Only Kit A4005	102	494798EVR	Primary Rplcmnt Kit A1004EVR-317A	62,91
493781	Boot & Face Kit A4005	102	494836SS	Primary Rim Kit A1004EVR-317SS, A1005-517/518	62
493785S	Replacement Collar Kit Self-Sealing Coax	21	494845	O-ring Kit A1005-505 & -517 Series	58,63
493820	Wrench Drain 494118, 493508K	61,72,94	494875	Adapter Kit 494551 Drain	61
493846	Front End Kit Spout/Boot A4005	102	494888SS	Handle Kit A1004EVR-316LID	62
493847	Front End Kit Spout/Boot A4015	102	494890	Sensor Test Port Cap	61
493855	Bellows Assembly A1005-001	63	494897	Flange Seal A1005-517GS	63
493885	Top Kit Female BSPT A0060-016	12	494952	Adapter Kit for 494118 Drain	61
493886	Top Kit Male BSPT A0060-015	12	495075	Flange/O-ring Kit, A1005-505, -517	58,63
493887	Top Kit Male A0060-022	12	495102	Mounting Kit, A1005-517	58,63
493888	Top Kit Female A0060-023	12	495202	Drain Plug Kit, A1005-505CEW	53,61
493889	Top Kit Male BSPT A0060-025	12	495229	Mounting Kit, A1005-517	63
493890	Top Kit Female BSPT A0060-026	12	495558K	Flange/O-ring Kit	62
494096	Riser Seal Assembly	89	495602	Drain Plug Kit, 493508K, 494118 Drains	61
494118	Drain Valve Kit w/Filter	61,89	495645	Mounting Kit for A0060 Shear Valve	14
494150EVR	Latch Kit A4005EVR	102	495649S	Top Kit Male A0060-222S	13
494240	Swivel Adapter Torque Wrench	72,96	495650S	Top Kit Female A0060-203S	13
494260	Bolt 5/8" w/O-ring 8" A0721 Lid	85	495651S	Top Kit Male A0060-202S	13
494261	Bolt 9/16" w/O-ring 8" A0721 Lid	85	495657S	Top Kit Femle A0060-223S	13
494262	Bolt 5/8" w/O-ring 12", 18" A0721 Lid	85	495668S	Top Kit Male BSPT A0060-215S	13
494263	Bolt 3/8" w/O-ring 5" A0721 Lid	85	495669S	Top Kit Female BSPT A0060-216S	13
494301	O-ring Kit, Swivel Adapters	6,10	495670S	Top Kit Male BSPT A0060-225S	13
494335	Lid for OPV 1-2100 Series Spill Cont.	67	495671S	Top Kit Female BSPT A0060-226S	13
494343	Test Adapter A1004-210TEST	73	495677	Drain Plug, A1003	61
494350EVR	Primary Rplcmnt Kit A1004EVR-210S	62,91	495696EVO	Secondary Replacement Kit A1004EVR-317SS	62
494360EVR	Primary Rplcmnt Kit A1004EVR-210A	62,91	495696DWP	Secondary Replacement Kit A1004EVR-316S/317S	62
494367	Dipstick Assembly A1004EVR	61	495880	Spacer Kit A1004EVR-216, A1005-616	63
494375	Bolt 9/16" w/O-ring 18" A0721 Lid	85	495953A	Top Tube Assy, A1100 OPV Modular, Anodized	21
494341A	Bottom Tube Assembly, A1100 OPV	21,23	495955A	Top Tube Assy, A1100 OPV Modular, Anodized	21
494406A	Bottom Tube Assembly, A1100 OPV	21,23	495956A	Top Tube Assy, A1100 OPV Modular, Anodized	21

Numerical Index

Model Number	Product Description	Page Number	Model Number	Product Description	Page Number
495957A	Top Tube Assy, A1100 OPV Modular, Standard	21	A0033-004	Debris Collector	7
495958A	Top Tube Assy, A1100 OPV Modular, Standard	21	A0060	Shear Valve	12,13
495959A	Top Tube Assy, A1100 OPV Modular, Standard	21	A0063	Vapor Shear Valve	14,101
496026-2	Primary & Secondary Replacement Kit A1005-616	63	A0065	Mounting Kit for A0060 Shear Valve	14
496400	Drop Tube A1100 OPV Modular Kit	18	A0066	Multi-Purpose Check Valve	29
563593	Gasket 12" Lid A0721	85	A0070	Drop Tube Coaxial	25
563639	Adapter Coax to NPT	113	A0075	Ball Float	25
563639AST	Adapter Vac Assist to Conventional	113	A0076	Vapor Adapter	10
563834	Clamp 52.2 mm A4005/A4015	106	A0076-124S	Vapor Swivel Adapter Brass	10,89
563980	Lid Ductile 12" A0721	85	A0078	Ball Float with Cage	26
564029	Lock/Key Set A0720	84	A0079	Extractor Fitting	24
565048	Scuff Black A4005/A4015	104	A0079-444	Extractor Tee	16,26,47
566675	Drill Fixture, Steel A1100	17,72,94	A0081-001	Wrench, Adapter	70,94
566965	Clamp 66.0 mm A4005/A4015	106	A0081-001H	Wrench, Spill Container w/Drain	70,94
567146	Gasket 8" Lid A0721	85	A0081-001L	Wrench, Adapter Lug	70,94
567150	Lid Ductile 8" A0721 White	85	A0081-001R	Wrench, Retrofit Lid	56,70
567177	Lid Ductile 12" A0717 Round	79	A0081-001S	Wrench, Secondary Flange	70
567712	Lid Ductile 18" A0721	85	A0081-001SET	Standard Tool Kit	70
567995	Gasket 18" Lid A0721	85	A0081-001SET-NB	Standard Tool Kit, Without Box	70
568348	Modular Tube Joint O-ring	18	A0081-001TB	Tool Box (Empty)	70
568662	Bolt 6" Lid A0721	85	A0081-003	Pipe Nipple Extractor	70
568692	Lid Ductile 6" A0721	85	A0081-003M	Wrench, Spill Container no Drain	71
568820	Gasket 6" Lid A0721	85	A0081-004CL	Cam-Lock Wrench	72,76
568961	Triple Wiper Seal 494335, A1005-505C Lids	67	A0081-006JP	Remote Fill Piping Test Assembly	16,47
569106	Lid Ductile 8" A0721	85	A0081-12TEST	Test Cover A1005-505 Series	58,73
569143	Test Cap Assembly, A1004-210TEST	72	A0081-13TEST	Test Cover A1004-316/A1005-517 Series	73
569227	Triple Wiper Seal 494554 Lid	66,91	A0081-15TEST	Test Cover A1004-210 Series	73
569285	Lid Ductile 8" Lay-in A0721	84	A0081-17TEST	Test Cover A1004-215 Series, A1005-505CP	58,73
569427	Euro Lift Handle A0716	72	A0081-1100	Testable Tool, A1100 Testable OPV	20
569461	O-Ring Drop Tube A1100EVR	18,93	A0084	Vent P-V	30
569723	Lid Ductile 12" Lay-in A0721	84	A0085	Vent Adapter	30
569883	Lid Cast 5" A0721	84	A0088	Drop Tube Coaxial Self-Sealing	25
569885	Gasket 5" Lid A0721	84	A0089	Tight Fill Adapter Coax A0088	7
569924	Gasket Kit, Swivel Adapters, A0076-005, A0585	7,10,27	A0096	Tight Fill Adapter Coax A0070	7
569989	Rim Gasket, Bellows A1004-316, A1005-616	62	A0097	Tight Fill Cap	8,89
570012	Triple Wpr Seal A1004-316LID; A1005-505C Lids	67,91	A0097-004LP	Tight Fill Cap Low Profile	8
570069	Rim Gasket A1004EVR-216, A1005-616	63	A0097-010	Fill Cap for Tank Probe	9,89
570739	Replacement Gasket A0097, A0099	9,11	A0099	Vapor Cap	11,89
571700	Lid Cast 7" A0721	85	A0099-004LP	Vapor Cap Low Profile	11
571702	Gasket 7" Lid A0721	85	A0099-001TEST	Vapor Test Cap	11,73
571814	Drill Fixture for Remote Fill	17	A0179	Extractor Cage	27
571815	Triple Wiper Seal A1004-210LID	66,67,91	A0279	Extractor Cage Test Plug	27
572719	Drill Fixture, Plastic A1100	17	A0333	Hand Pump Spill Container	68
572819	Spacer Kit A1004EVR-316	62	A0360	Hose Swivel	112
573728	Rim Adapter A1004EVR-216, A1005-616	63	A0379	Remote Fill Cage Adjustable	16,46
A0010	Flow Regulator	113	A0479-001	Dip Stick Port	16,46
A0020	Drop Tube	24	A0500	Splash Guard A2500/A2501	107
A0020EVR	Drop Tube EVR	24,94	A0557EVR	Scuff Guard A4005EVR	102
A0028	Riser Lock	68	A0560	Wrench For Buckeye Cage	27
A0030	Tight Fill Adapter	6	A0585-003	Extractor Pipe Cap Bar Style	27
A0030-014	Automatic Tank Gauge Adapter	6,89	A0716	Composite Manhole	76-79
A0030-124S	Tight Fill Swivel Adapter Brass 4"x4"	6,89	A0717	Standard Manhole, Round	80-81
A0031	Riser Extension	59	A0717	Standard Manhole, Square	82-83
A0032-001	Adapter Clamp	7	A0717	Vault	82-83

Numerical Index

Model Number	Product Description	Page Number	Model Number	Product Description	Page Number
A0720	Monitoring Well Cap & Collar	84	A1100-010T	Overfill Prevention Valve Testable	20
A0721/A0722	Monitoring Well Manhole	84-85	A1100-056SRF	OPV Dual Point Remote Fill	16
A0727	Well Protector Square	86	A1100-06xS	Overfill Prevention Valve Coaxial	22
A0729-048	E-Stop Switch Pedestal	114	A1100-06xST	OPV Coaxial Top Tube Assembly	23
A0732	Union Check Valve 1 1/2"	29	A1100-08xS	OPV Coaxial Self-Sealing	22
A0750	Ball Valve	29	A1100-08xST	OPV Coaxial Top Tube Assembly	23
A0785	Vent Downward 1.5" / 2" Female	31	A1100-08xTP	OPV Coaxial Self-Sealing Testable	20
A0996	ID Tag	32	A1100EVR	Overfill Prevention Assy EVR Dual Point	17,93
A0997	Tank ID Tag	32	A1100EVR-010M	OPV Valve Only Modular	18,21
A0998	In-Ground ID Marker	32	A1100EVR-05xM	OPV Dual Point Modular	18
A1004	Spill Cont Non-Replacable Poly 5gal	45	A1100EVR-05xS	OPV Dual Point Screw Top	21
A1004-001GAGE	EZ-Gage	61	A1100EVR-05xST	OPV Dual Point Top Tube Assembly	23
A1004-001SEN	Sensor Kit	61	A1100EVR-05xT	Overfill Prevention Valve Testable	20
A1004-210LID	Lid A1004-210 Series	66,91	A2119	SafeBreak 3/4"x3/4" Shearpin	110
A1004-210TEST	Vacuum Apparatus w/Test Adptr	58,73	A2219	SafeBreak 3/4" Reconnectable	110
A1004-316LID	Lid A1004-316, A1005-517 Series	64,91	A3019	SafeBreak 1" Shear Pin	110
A1004EVR-010	Spill Cont Non-repl SW Poly, EVR	45,90	A3219	SafeBreak 1" Reconnectable	110
A1004EVR-216A	Spill Cnt Rpl SW Poly, EVR 15 gal	45,90	A4005	Balance Nozzle	105
A1004EVR-216SJ	SC Rpl SST Pri, Poly Sec, EVR 15 gal	45,90	A4005EVR	Balance Nozzle EVR	99
A1004EVR-242	Spill Containment, Multi-Port, EVR	50,92	A4015	Balance Nozzle Short Spout	106
A1004EVR-316A	Spill Cnt Rpl SW Poly, EVR 5 gal	44,90	A4041	Splitter Coax	112
A1004EVR-316S	Spill Cnt Rpl DW Poly, EVR 5 gal	44,90	A4043	Splitter Not Vapor Ready to Coax	112
A1004EVR-317SS	SC Rpl SST Pri, Poly Sec, EVR 5 gal	39,90	A4103	Vent Upward "V" Alum 2"	31
A1004EVR-317SS900	SC Retrofit Stnls Stl OPW 500&700	56	A4110EVR	Swivel Coaxial 45 Degree	98,111
A1005-015TM	Tank Monitor SW SST	43	A4119EVR	SafeBreak Coaxial Shear Pin	99,111
A1005-501T	Spill Cont Non-repl Thread-On 5gal	43	A7900-004H	Male Pipe Plug NPSM	16,47
A1005-505C	SC Retrofit OPW Stnls Stl Insert	55	A7901	Pipe Nipple	60
A1005-505CE, CF1	SC Retrofit Franklin SST Insert	54	A7901-3xxK	Adptr Kit A1005-505CEW1,CEW2	58
A1005-505CEW	SC Retrofit Emco SST Insert	53	A7904-004	Merchant Steel Coupling	60
A1005-505CF5	SC Retrofit Fairfield SST Insert	54	A7904-500	Short Pipe Coupling	60
A1005-505CP	SC Retrofit Pomeco SST Insert	57	Z0838	Anti-Seize Joint Seal	34
A1005-505CPEM	SC Retrofit Pemco SST Insert	54	Z0839	Urethane Super Duty Sealant	34
A1005-505CL	Lids Retrofit Stainless Steel	67			
A1005-505CU	SC Retrofit Universal SST Insert	57			
A1005-505DP	Drain Plug Kit A1005-505C	55			
A1005-505DPE	Drain Plug Kit A1005-505C Epoxy	55			
A1005-505DPEB	Drain Plug Kit A1005-505CE	54			
A1005-505DPU	Drain Plug Kit A1005-505CU	55			
A1005-517	Spill Cont Non-repl Slip-On 5 gal	43			
A1005-517A	SC Repl SW Slip-On Stnlss Steel	40			
A1005-517AW-DEF	Spill Cnt Repl SW Slip-on SST DEF	41			
A1005-517G	SC Repl DW Slip-On Stnlss Steel	40			
A1005-517SF	SC Repl DW Remote Fill	46-47			
A1005-518A	SC Repl SW Thread-On Stnlss Stl	40			
A1005-518AW2DEF	Spill Cnt Repl SW Screw-on SST DEF	41			
A1005-518G	SC Repl DW Thread-On Stnlss Stl	40			
A1005-518GW2DEF	Spill Cnt Repl DW Screw-on SST DEF	41			
A1005-518R	SC Retrofit SST Male Nipple OPW 500&700	56			
A1005-616RD	SC Rpl SST Prmy, Poly Sec, 15 gal	42			
A1005-616SF	SC Rpl DW Remote Fill, 15 gal	46			
A1005-761-DEF	SC Remote Fill Vault- 1 Fill	48			
A1005-764-2001	SC Remote Fill Vault- 3 Fill + Vapor	49			
A1005-905	SC Repl Below Grade 5 gal	42			
A1005-915	SC Repl Below Grade 15 gal	42			
A1008	Spill Containment, Multi-Port	51			
A1100-010	Overfill Prevention Valve	15,17			

Warranty Policy

Emco Wheaton Retail Corporation service station products are warranted to be free from defects in material and workmanship under normal use and service. Non-EVR Vapor recovery nozzles are warranted for a period of twelve (12) months from date of shipment from Emco Wheaton Retail Corporation or from installation date as specified by the returned warranty card, not to exceed fourteen (14) months from the date of shipment from Emco Wheaton Retail Corporation. This warranty excludes the spout and/or front end components of balance vapor recovery nozzles unless damage is obvious when the nozzle is removed from the shipping carton and the defective nozzle is returned to Emco Wheaton Retail Corporation prior to use and within two (2) months from the date of invoice. EVR vapor recovery hanging hardware components are subject to other specific warranty conditions as stated in a separate warranty policy. Other service station products are warranted for a period of twelve (12) months from the date of manufacture.

Emco Wheaton Retail Corporation shall, at its option, repair or replace that part which proves to be defective. Repaired or replacement nozzles are warranted for the balance of the original warranty period. This warranty is void unless the original purchaser returns the claimed defective item to Emco Wheaton Retail Corporation for inspection to determine whether the claimed defect is covered by this warranty.

The exclusive and sole remedy under this warranty is repair or replacement of the defective part. Emco is not responsible for claims for damage caused by improper installation or maintenance; corrosive fluids; misuse of the product or use the product for other than its intended purpose; or accident, acts of God, or natural phenomena. Emco will not pay for labor or related expenses, nor shall Emco be liable for any incidental, consequential or exemplary or other damages, including without limitation lost profits. This warranty is void if the Emco Wheaton Retail Corporation product has been previously repaired with parts not approved by Emco Wheaton Retail Corporation, or if a nozzle bears the mark or imprint of a company other than Emco Wheaton Retail Corporation, indicating the nozzle has been rebuilt or repaired by a company other than Emco Wheaton Retail Corporation.

EMCO WHEATON RETAIL CORPORATION MAKES NO OTHER WARRANTIES, EXPRESS OR IMPLIED, (WHETHER WRITTEN OR ORAL), INCLUDING BUT NOT LIMITED TO ANY IMPLIED WARRANTY OF MERCHANTABILITY OR FITNESS FOR ANY PARTICULAR PURPOSE.

In the event a nozzle is returned to Emco Wheaton Retail Corporation within the warranty period described above, and when tested is found to be functional and without defect, Emco Wheaton Retail Corporation reserves the right to return the nozzle to the customer or apply a Core Credit (see Nozzle Core Return Program), at Emco Wheaton Retail Corporation's discretion.

In the event of failure within the warranty period, call the Customer Service Department at (800) 234-4394. Describe the problem and provide the product date stamp information to the customer service representative. In the case of a nozzle, provide the serial number. The customer service representative will provide a product complaint number, if applicable. Ship the defective equipment PREPAID, to Emco Wheaton Retail Corporation for repair or replacement.

Emco Wheaton Retail Corporation products should be used in compliance with applicable federal, state and local laws and regulations. Product selection should be based on physical specifications and limitations and compatibility with the environment and material to be handled. All illustrations and specifications are based on the latest product information available at the time of publication. Emco Wheaton Retail Corporation reserves the right to make changes at any time in prices, materials, specifications and models and to discontinue models without notice or obligation.

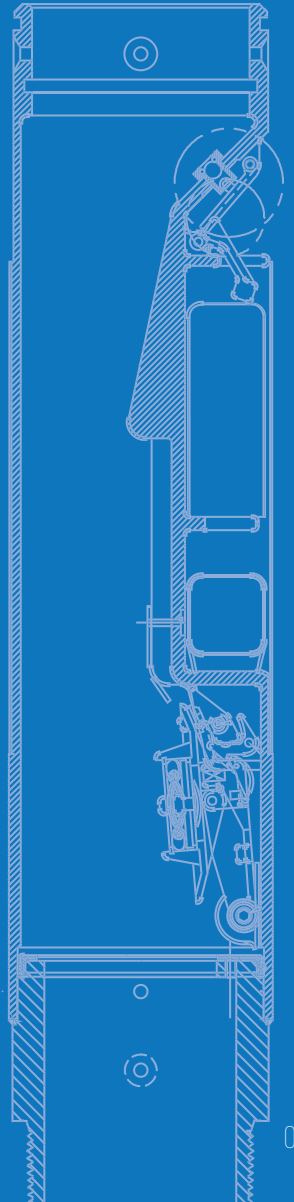
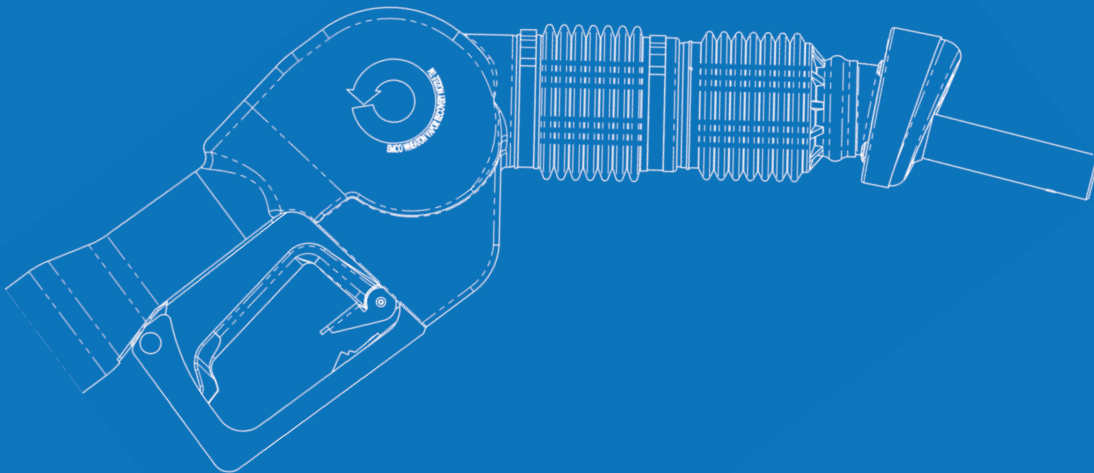
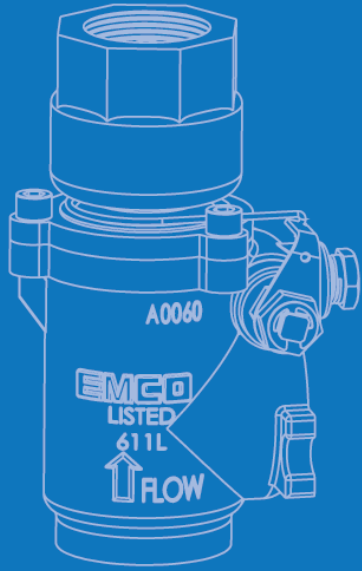

2300 INDUSTRIAL PARK DRIVE • WILSON, NC 27893
PH: 252-243-0150 • FAX: 252-243-4603 • WWW.EMCORETAIL.COM