

Balance Phase II Pre-EVR Components

A4005 Vapor Recovery Nozzle w/Vapor Valve

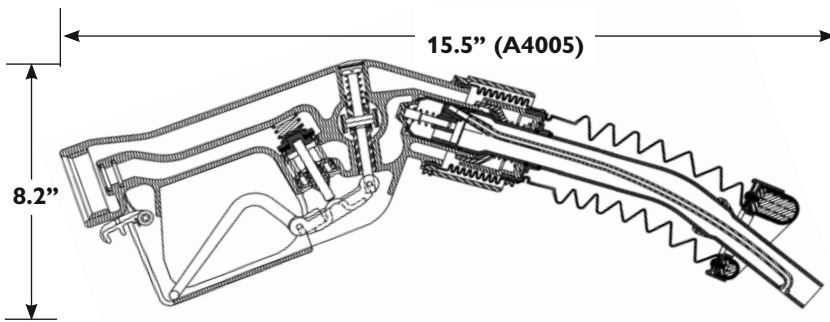

- CARB Executive Orders G-70-17-AD, G-70-52-AM, G-70-199-AJ
- UL Listed MH1460 Classified to UL 2586
- Approved by the N.Y. Department of Environmental Conservation and the Oregon Department of Environmental Quality

The A4005 Vantage has proven itself as the balance vapor recovery nozzle of choice. Developed to be user friendly, the A4005 utilizes the most up-to-date vapor recovery technology available.

The A4005 offers the same lightweight and streamlined design advantages characteristic of the A4000 series product line. A low restriction vapor valve is built into the A4005 so it does not require an external vapor valve. This nozzle includes the no-seal, no-flow interlock mechanism and automatic shutoff for reliable, safe operation. It also has an internal pressure shutoff to detect vapor blockage.

Material

Body & Spout: Aluminum
 Lever: Thermoplastic
 Lever Guard: Aluminum
 Seals: Nitrile & Viton®
 Scuff Guard: Vinyl

Viton® is a registered trademark of The Chemours Company.

Model No.	Description	Lbs.
A4005-002	New Unleaded	4.6
A4005-004	Rebuilt Unleaded	4.6
A4005-002E	New Unleaded E85	4.6

The above part numbers include the standard glossy black scuff guard.

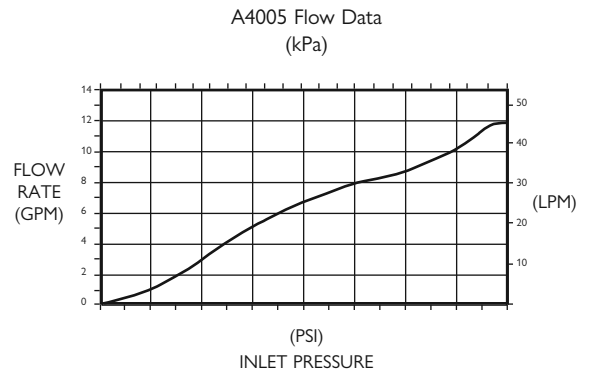

Balance System

A4005 Balance Nozzle

A4005 Replacement Parts

Kit No.	Description	Lbs.
493040	Spout Kit - Unleaded	2.0
493042	Boot Face Kit	0.2
493047	Clamp & Cover Kit	0.4
493062	Latch Kit	0.1
493781	Boot & Face Kit	0.7
493846	Front End Kit - Spout/Boot	1.5
563834	Clamp 52.2 mm	0.2
566965	Clamp 66.0 mm	0.3
565048	Scuff Guard, Black Emco Logo	0.4

A4015 Replacement Parts

Kit No.	Description	Lbs.
493042	Boot Face Kit	0.2
493047	Clamp & Cover Kit	0.4
493062	Latch Kit	0.1
493398	Spout Kit - Unleaded	0.6
493400	Boot & Face Kit	0.5
493847	Front End Kit - Spout/Boot	0.9
563834	Clamp 52.2 mm	0.2
566965	Clamp 66.0 mm	0.3
565048	Scuff Guard, Black Emco Logo	0.4

Nozzle & Breakaway Core Credit Policy

Models Allowed For Core Credit	Core Credit Value	Return for Credit Against the Following
Nozzles		
A4005	\$45	Rebuilt A4005
A4015	\$45	Rebuilt A4005
A4005EVR	\$85	New A4005EVR
Competitor EVR Nozzle	\$85	New A4005EVR
Breakaways		
A4119EVR-020 or A4119EVR-020RC	\$10	New A4119EVR-020RC
A4119EVR-020 or A4119EVR-020RC	\$25	New A4119EVR-020
Competitor EVR Breakaway	\$25	New A4119EVR-020

Credits: All nozzle and breakaway cores must be returned within 90 days of invoice to be eligible for credit.

Cores with cracked bodies, stripped threads or damaged in any way that limits their ability to be rebuilt will not be accepted for credit.

Nozzle cores returned without a front end assembly (spout, bellows and boot face) or any other part will be subject to a 50% core credit reduction.

Breakaway cores must be returned as a complete unit (both male and female halves) to be eligible for a core credit.

Invoicing: Nozzle and breakaway models allowed for core credit will be invoiced at list price less your distributor discount. Acceptable cores will be credited against those invoices.

Freight: Inbound freight charges for nozzle and breakaway cores returned for credit must be prepaid by the distributor.

Core Bank: Nozzle and breakaway cores may be sent to Emco in anticipation of future purchases. Emco will store all cores in the distributor's account for a maximum time period of 18-months from date received. All cores stored longer than 18 months will be discarded and no credit given.