

# Balance Phase II EVR Components

## A4119EVR Coaxial SafeBreak® Valve

### Reconnectable

The Model A4119EVR-020RC Coaxial SafeBreak® Valve is a shear pin style field reconnectable component designed for use with Balance Phase II Vapor Recovery systems. Complies with California Air Resources Board CARB Enhanced Vapor Recovery EVR Certification Procedures CP-201. A dual poppet design seals off both the fuel and vapor paths upon separation due to customer related "drive-off" events, eliminating fuel spillage and vapor emissions, and minimizing damage to the dispenser unit.

Model	Description	Lbs.
A4119EVR-020RC	Reconnectable Coaxial SafeBreak® Valve	1.3
A4119EVR-020RCS	Factory Serviced Reconnectable Coaxial SafeBreak® Valve	1.3
572909	Clamp Tool	1.9
495989	Clamp Tool Plate Kit	1.0

#### Repair Kits & Replacement Parts

494748EVR	Fuel Path O-ring Kit
495820	Shear Pin Kit
495843	Snap Cover Kit
495866	Scuff Guard Kit

#### Material

Body: Aluminum  
O-rings: Buna-N  
Protective Cover: Santoprene

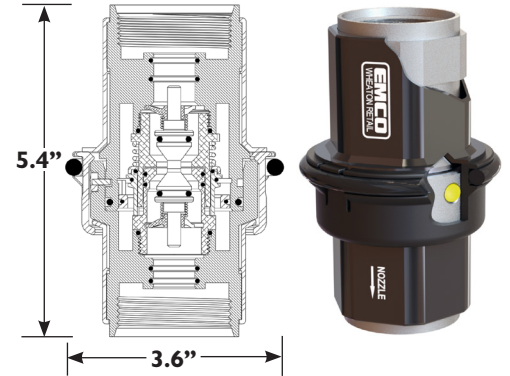

- CARB EVR Executive Orders VR-203, VR-204, VR-207, VR-208, VR-501  
UL Listed MH17833

### Non-reconnectable

The A4119EVR-020 Coaxial SafeBreak Valve is a shear pin style non-reconnectable component designed for use with Balance Phase II Vapor Recovery Systems. Complies with California Air Resources Board CARB Enhanced Vapor Recovery EVR Certification Procedures CP-201. A dual poppet design seals off both the fuel and vapor paths upon separation due to customer related "drive-off" events, eliminating fuel spillage and vapor emissions, and minimizing damage to the dispenser unit.

Model No.	Description	Lbs.
A4119EVR-020	Coaxial Shear Pin	1.6

#### Repair Kits & Replacement Parts

494748EVR	Fuel Path O-ring Kit
-----------	----------------------

#### Material

Body: Aluminum  
O-rings: Buna-N  
Protective Cover: Vinyl

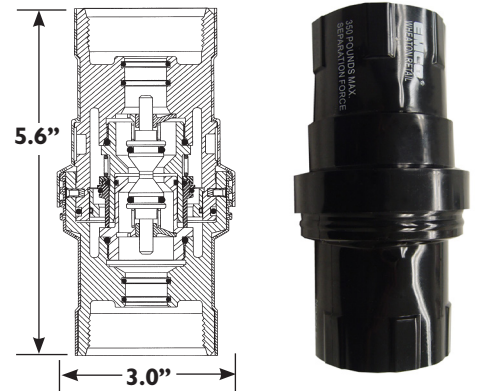

- CARB EVR Executive Orders VR-203, VR-204, VR-207, VR-208, VR-501  
CARB Pre-EVR Mix & Match Approval Letter #09-10/Advisory #408  
UL Listed MH17833

## A0063EVR Vapor Shear Valve

The A0063EVR vapor shear valve installs on the phase II vapor riser below the dispenser to eliminate the escape of vapors in the event of a collision to the dispenser. The double poppet valve incorporates a 1.5" female NPT connection to the underground piping and a 1" female NPT connection to dispenser piping. The valve incorporates a 3/8" test port. Mounting Kit is included. Approved for use with all CARB certified pre-EVR and EVR phase II vapor recovery systems.

Model No.	Description	Inlet	Outlet	Lbs.
A0063EVR-024	1 1/2" Double Poppet	Female	Female	9.0

#### Material

Body: Cast Iron  
Spring: Stainless Steel  
Seal: Viton®

Viton® is a registered trademark of The Chemours Company.

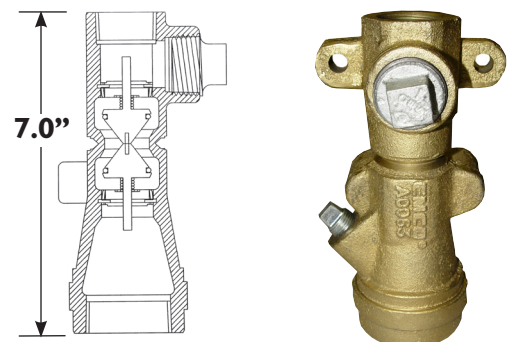

- UL Listed MH10206