

Spill Containment

Retrofit Accessories

A7901 Adapter

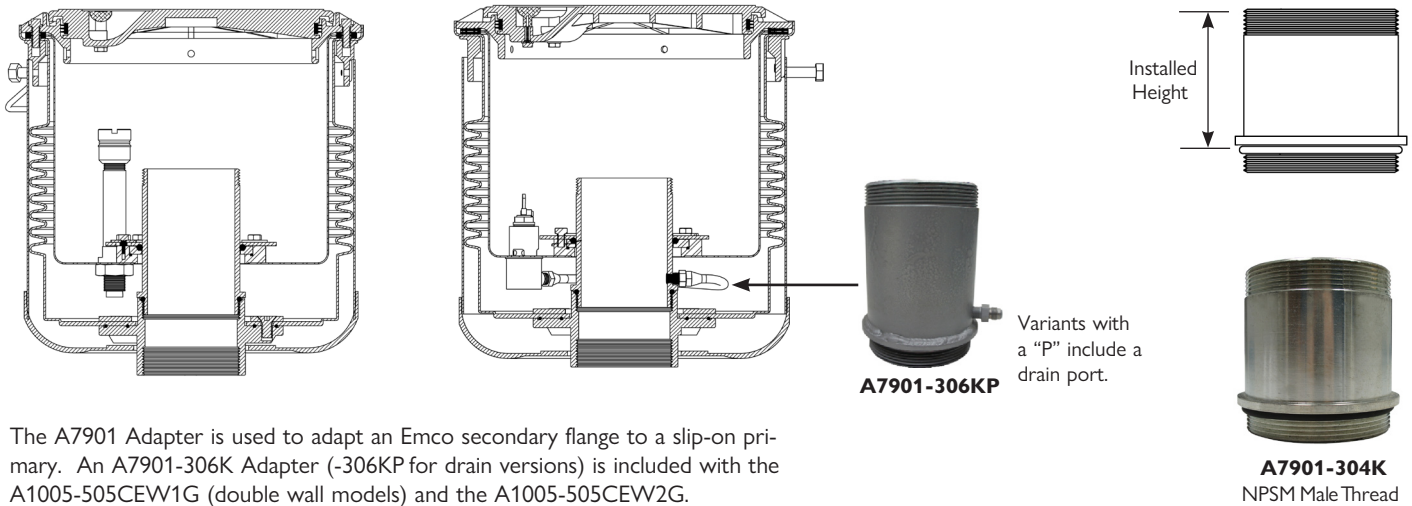

The A7901 Adapter is used to adapt an Emco secondary flange to a slip-on primary. An A7901-306K Adapter (-306KP for drain versions) is included with the A1005-505CEW1G (double wall models) and the A1005-505CEW2G.

Part No.	Installed Height	Description	Lbs.
A7901-304K	4.0"	A1005-505CEW1, CEW2	4.0
A7901-304KP	4.0"	A1005-505CEW1, CEW2	4.1
A7901-305K	5.0"	A1005-505CEW1, CEW2	4.5
A7901-306K	6.0"	A1005-505CEW1, CEW2	7.5
A7901-306KP	6.0"	A1005-505CEW1, CEW2	7.6

Retrofit Replacement Parts

Part No.	Description	Lbs.
494845	O-ring Kit, A1005-505 Series Includes 2 O-rings	
495075	Flange/O-ring Kit, A1005-505C Includes 2-piece Ring Flange, Bolts, O-ring	1.0
495102	Flange/O-ring Kit, A1005-505 Series Includes 3-piece Ring Flange, Bolts, Washers, Eccentric Ring, 2 O-rings, Grounding Clip	1.9



494845
O-Ring Kit



495075
A1005-505C Kit



495271
A1005-505 Series Kit

Retrofit Testing Equipment

Part No.	Description	Diameter	Lbs.
A1004-210TEST	Vacuum Test Apparatus	N/A	5.0
A0081-12TEST	Test Cover	12.40"	4.5
A0081-17TEST	Test Cover (-505CP)	17.38"	5.0

The A1004-210TEST is used with the A0081 Test Covers to perform vacuum testing on the A1005-505C Series Retrofit Spill Containment. For additional applications, refer to page 69.



A1004-210TEST

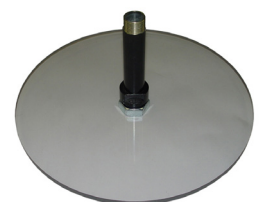

A0081-12TEST