

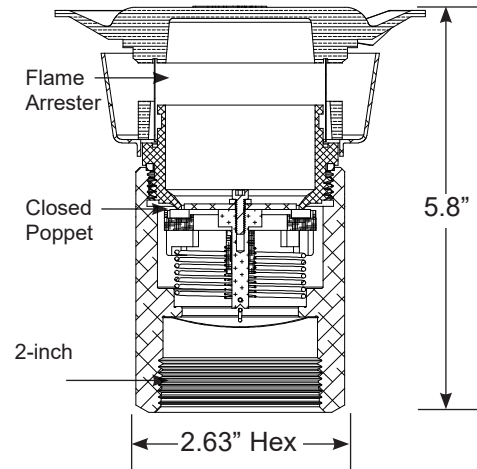

A0084 P/V Vent Valve

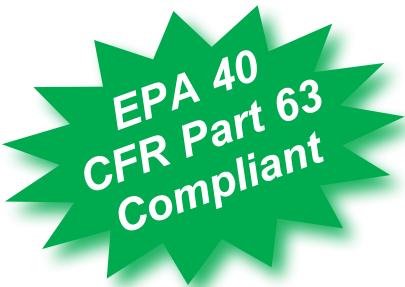

Guide Specification: The Model A0084 Pressure/ Vacuum Vent Valve typically installs on top of the tank vent pipes for both underground and aboveground fuel storage tanks. The valve eliminates fuel evaporation and vapor fugitive emissions from escaping into the atmosphere harming air quality standards. The top of the valve is domed with a water channel to quickly drain off moisture, rain, snow and ice. A flame arrester/ wire mesh screen is secured around the opening of the valve to keep free of insects and debris from entering or blocking the tank vent pipe. A normally closed poppet within the valve opens at a predetermined pressure or vacuum setting to allow the tank to vent (see chart below). The valve is CARB pre-EVR approved and complies with the following EPA performance standard; leak rate shall not exceed 0.17 CFH at 2.0 inches of water column pressure, and 0.63 CFH at 4.0 inches of water column vacuum. The valve comes standard with a 2-inch NPT thread connection. The valve allows for field serviceability.

Model No.	Inlet	Pressure Setting	Vacuum Setting
A0084-038	2-inch NPT	2.5"-6.0" WC	6.0"-
A0084-103	2-inch Slip-on	2.5"-6.0" WC	6.0"-10.0" WC
A0084-338	3-inch NPT	2.5"-6.0" WC	6.0"-10.0" WC
A0084-303	3-inch Slip-on	2.5"-6.0" WC	6.0"-10.0" WC
A0084-001	2-inch NPT for Diesel Applications	N/A	N/A
A0084-038K	Poppet Repair Kit		

Guide Specification: The Model A0085 Vent Adapter is designed to thread directly into the base of the Model A0084-038 Pressure/Vacuum Vent Valve. This allows for the installation on a 3-inch tank vent pipe, threaded or slip-on.

Model No.	Description
A0085-302	3-inch NPT
A0085-302S	3-inch Slip-on

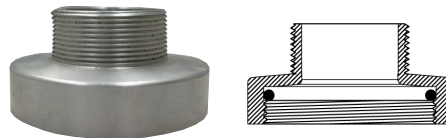

Material:

Body: Anodized Aluminum
Seal: Viton
Label: Permanent Adhesive

Certification & Listing:

EPA 40 CFR Part 63
CARB Pre-EVR Approval Letter #92-21
UL Listing MH46838

Emco Wheaton Retail Corporation

2300 Industrial Park Dr. • Wilson, North Carolina 27893 • 252-243-0150 • 252-243-4603 (fax) • www.emcoretail.com