

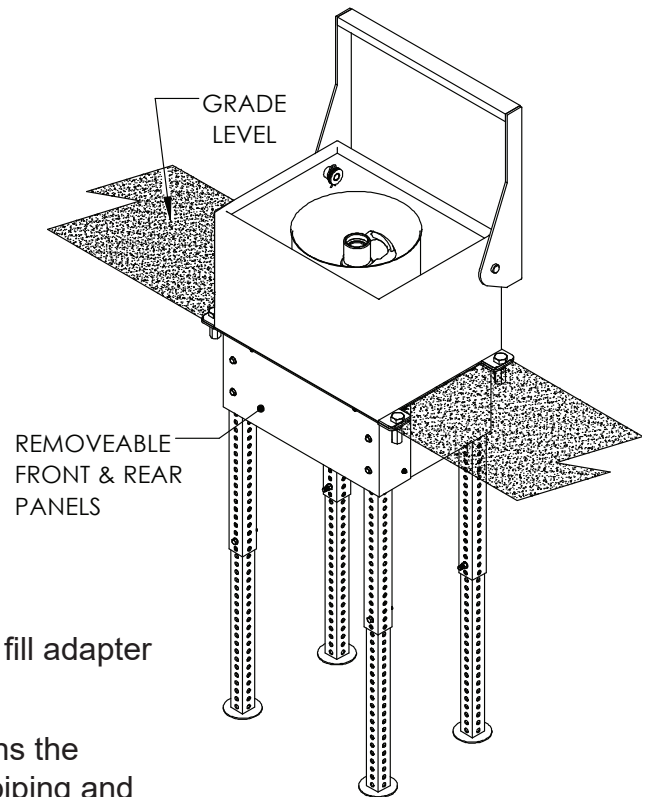

A1005-761-DEF2 A1005-761-DEF3 Above Ground Remote Fill Containment Sump

**Perfect for DEF
2" or 3" Piping Nipple Included**

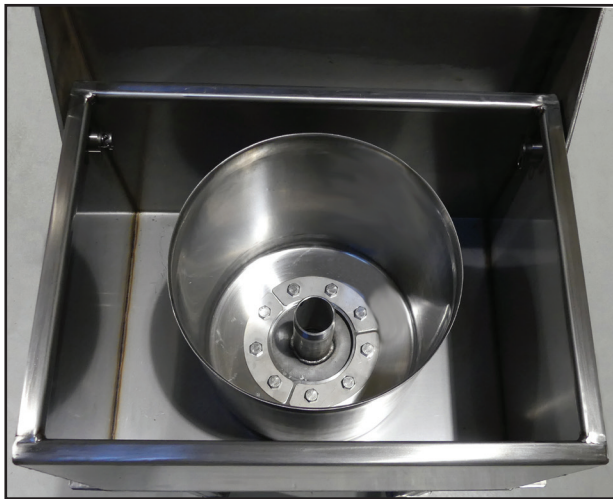

- Double wall spill containment
- All stainless steel construction
- 2" or 3" stainless steel piping for attachment to fill adapter and piping-NPT threads for DEF
- Adjustable leg height (from 2 ft. to 4 ft.) positions the spill container at grade level for installation of piping and backfilling
- Removable stainless steel skirt for ease of installation
- Hinged lid for easy access
- Available options:

- Lockable lid

Model No.	Description
A1005-761-DEF2	Above Ground Remote Fill Containment Sump, 1 Fill, 2" piping
A1005-761-DEF3	Above Ground Remote Fill Containment Sump, 1 Fill, 3" piping

Emco Wheaton Retail Corporation

2300 Industrial Park Drive • Wilson, North Carolina 27893 • 252-243-0150 • 252-243-4603 (fax) • www.emcoretail.com