

# EMCO®

MULTI-PORT | EVR SYSTEM  
EXECUTIVE ORDER VR-105



**Affordable • Watertight • Serviceable • Compliant**

**Emco Wheaton Retail Corporation**

2300 Industrial Park Drive • Wilson, North Carolina 27893 • 252-243-0150 • 252-243-4603 (fax) • [www.emcoretail.com](http://www.emcoretail.com)

P-1011  
12/19



**Guide Specification:**

- 42-inch steel diamond plate lid with 16-inch tank bung spacing  
**Optional diamond plate lid in light weight aluminum**
- 6 cam-locks and dual lid handles for easy lock-down and removal
- 8-inch observation port w/ water tight seals
- All mounting bolts non-corrosive stainless steel
- Manhole rim channel w/ D-seal for water tightness integrity between lid and rim
- Manhole available w/ 12-inch or 18-inch galvanized skirt
- Nominal spill container capacity of 5 US gallons
- Cast iron spill container base w/ 4-inch NPT thread connection  
**Requires no face seal adapter**
- Powder coated, heavy duty, cast iron lid and ductile iron plow ring, exceeds DOT H-20 loading  
**Optional lid in composite material**
- Lid w/ triple wiper seal
- HDPE primary spill container bellows
- Drain valve w/ filter or plug option
- Compatible with most water shrouds and boot kits

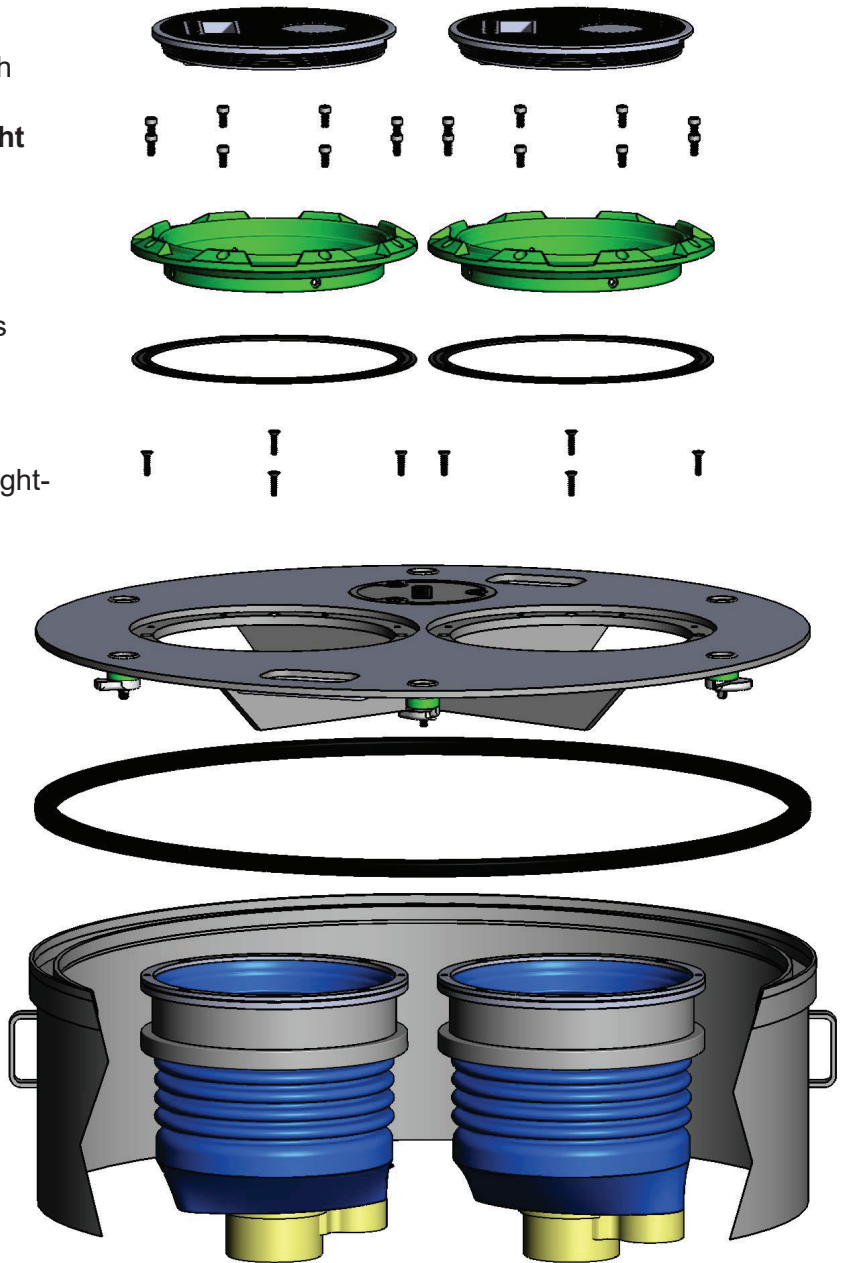

Model No.	Description	Spill Container #1	Drain Type	Spill Container #2	Drain Type
A1004EVR-2421D1A	42" Multi-Port MH, 8" Observation Port 12" Skirt, Gasoline	SW, 5 gal	Drain Valve	SW, 5 gal	No Drain
A1004EVR-242101A	42" Multi-Port MH, 8" Observation Port 12" Skirt, Gasoline	SW, 5 gal	No Drain	SW, 5 gal	No Drain
A1004EVR-2421D0A	42" Multi-Port MH, 8" Observation Port 12" Skirt, Diesel	SW, 5 gal	Drain Valve	None	N/A
A1004EVR-242100A	42" Multi-Port MH, 8" Observation Port 12" Skirt, Diesel	SW, 5 gal	No Drain	None	N/A

*Custom configurations are available upon request*



# A1100EVR Overfill Prevention Valve

## Guide Specification:

- 1 Upper drop tube to valve body factory welded  
**Optional:** Upper drop tube and collar factory anodized to prevent corrosion
- 2 Bleed valve drains fuel delivery hose after 95% shut-off
- 3 Diverter fins protect flapper valve during routine "tank stick" gauging
- 4 Top and bottom floats contained in protective sleeve to insure damage-free installation and removal from tank fill riser
- 5 Die cast aluminum valve body design provides the highest delivery flow rate
- 6 Spring loaded reset function opens flapper valve and allows for immediate "tank stick" gauging
- 7 Flapper valve provides positive fuel shut-off at 95% total storage tank capacity
- 8 External field test port allows for manual routine testing of flapper valve
- 9 Valve body to male coupling factory welded
- 10 Female coupling to lower drop tube factory welded
  - All materials and seals are compatible with up to E25 ethanol blend gasoline and B20 biodiesel blends
  - 100% factory tested for operability and vapor tightness integrity
  - For underground storage tanks less than 6.5' in diameter, please consult your local EMCO Factory Representative

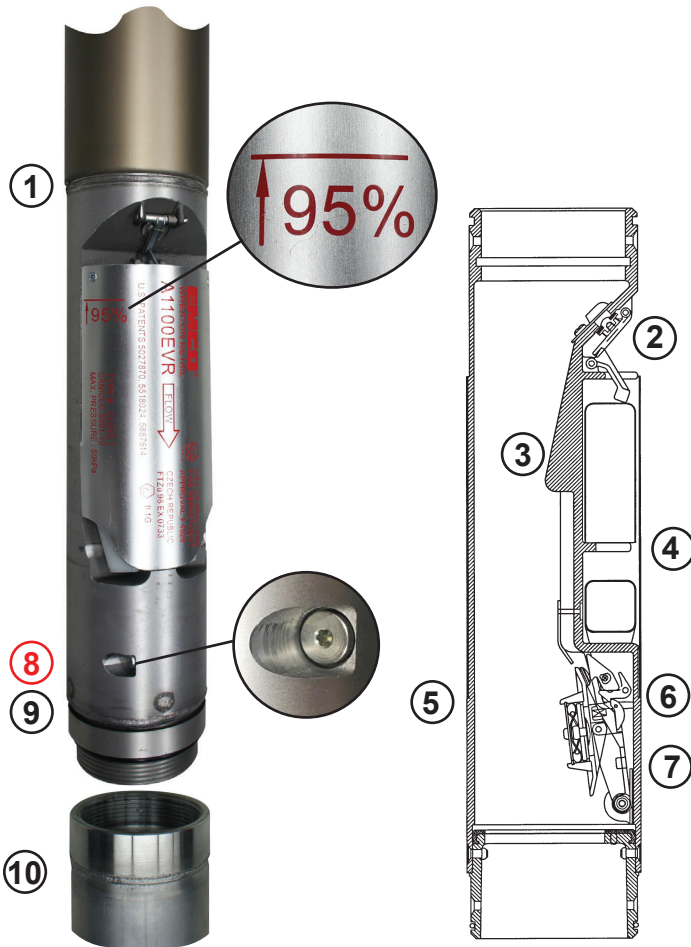

Model No.	Anodized Model No.	Overall Length	Maximum Burial Depth	Nominal Tank Diameter	Weight
A1100EVR-055	A1100EVR-055CF	14.0 ft.	6.0 ft.	8 ft.	25.2 lbs.
A1100EVR-056	A1100EVR-056CF	16.0 ft.	7.0 ft.	10 ft.	27.2 lbs.
A1100EVR-057	A1100EVR-057CF	18.2 ft.	6.8 ft.	12 ft.	30.3 lbs.
A1100EVR-058	A1100EVR-058CF	21.7 ft.	10.0 ft.	12 ft.	31.0 lbs.



**A0020EVR**  
Rolled Edge Collar



**A0020EVR**  
Heavy Duty Collar

# A0020EVR Straight Drop Tube

## Guide Specification:

- 4-inch diameter aluminum construction
- Available standard rolled edge or heavy duty collar
- Installs on a typical 4-inch tank fill riser

Model No.	Model No.	Overall Length
A0020EVR-004	A0020EVR-004	12'
A0020EVR-005	A0020EVR-005	15'





**A0097-005**  
Fill Adapter Cap



**A0099-002**  
Vapor Adapter Cap



**A0097-010**  
ATG Probe  
Adapter Cap



**A0097-004LP**  
Low Profile  
Fill Adapter Cap



**A0099-004LP**  
Low Profile  
Vapor Adapter Cap



**A0030-124S**  
Swivel Fill Adapter



**A0076-124S**  
Swivel Vapor  
Adapter



**A0030-014**  
Tall ATG  
Probe Adapter



**A0030-024ATG**  
Short ATG Probe  
Adapter



**494096 Riser Seal**

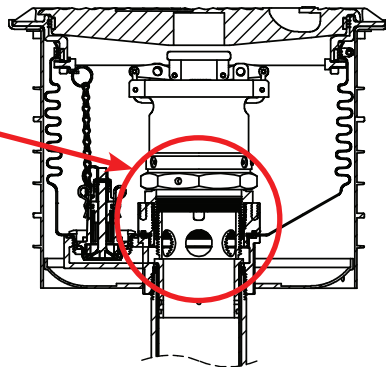

**A0075**  
Ball Float



**A0079 Extractor**  
Cross Fitting



**A0079 Extractor**  
Tee Fitting



**A0179**  
Extractor Cage



**A0279 Extractor**  
Test Plug

**Guide Specification:**

- Top-seal cam and groove design for vapor tightness integrity
- Aluminum body powder coated orange or gray for field identification
- Lockable toggle action aluminum handle with self-aligning cams
- The Model A0099-003 includes a 12-inch chain to prevent theft
- The Model A0097-010 includes cord grip for use with ATG probes
- **A0097-010A includes A0097-010ATG probe cap and A0030-024ATG adapter**

**Guide Specification:**

- A 360 degree rotation prevents accidental loosening from 4-inch tank fill or vapor riser
- Brass construction cam and groove design for use with top-seal caps for vapor tightness integrity
- Flat gasket with 4-inch NPSM thread connection
- The Model A0076-124S available with a normally closed poppet
- The Model A0030-014 and A0030-024ATG are non-swivel for use with ATG probes
- Allows for complete field serviceability should the swivel adapter fail CARB static torque TP-201.B, leak tightness integrity tests TP-201.D or TP-201.3

**Guide Specification:**

- Lowers the top of the drop tube collar below the spill containment drain valve path
- Two-piece stainless steel construction