

A tank top manway is required for all configurations.

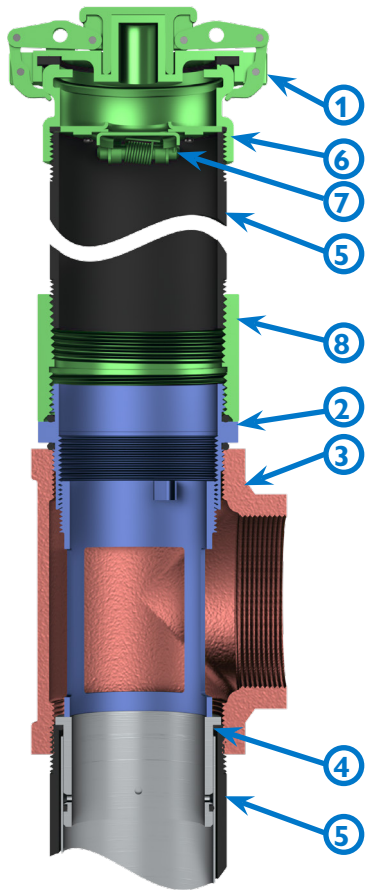

CARB EVR APPROVED

Item	Part Number	Material
1	A0097-005	PC Alum
2	494096R	SST
3	A0079-444SS	SST
4	A1100 Collar	Ano Alum
5	4" SCH 40 Riser Pipe	Steel/SST
6	A0030-024	Brass
7	A0479-001	SST
8	A7904-005S	SST

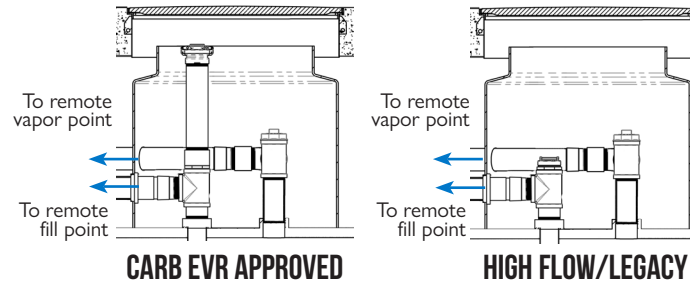
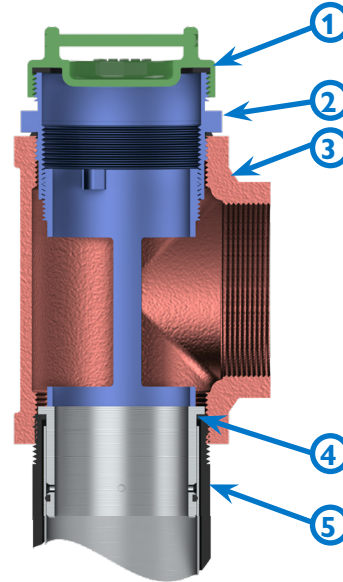

HIGH FLOW

Item	Part Number	Material
1	A0585-003	PC Alum
2	494096R	SST
3	A0079-444SS	SST
4	A1100 Collar	Ano Alum
5	4" SCH 40 Riser Pipe	Steel/SST

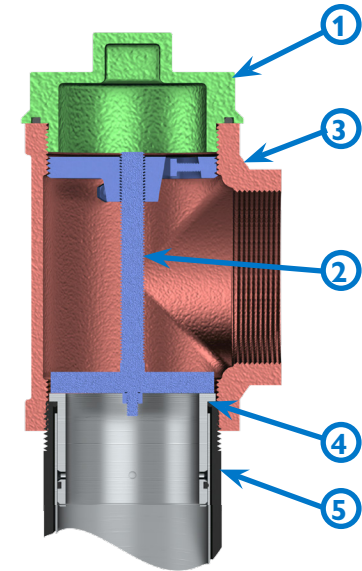

LEGACY

Item	Part Number	Material
1	A7900-004H	PC Steel
2	A0379-001	PC Steel
3	A0079-444SS	SST
4	A1100 Collar	Ano Alum
5	4" SCH 40 Riser Pipe	Steel/SST

- » No special riser pipe requirements: a standard schedule 40 riser pipe is acceptable for all configurations.
- » Remote fill tee (Item 3) is available in stainless steel (A0079-444SS) or cast iron (A0079-444)
- » Fill adapter (Item 6) is available in brass (A0030-024) or aluminum (A0030-024A)