

EMCO[®]

A0030-124S/A0076-124S Swivel Adapters



Affordable • Serviceable • Compliant

EMCO WHEATON RETAIL CORPORATION
2300 Industrial Park Drive • Wilson, North Carolina 27893
252-243-0150 • 252-243-4603 (fax) • www.emcoretail.com

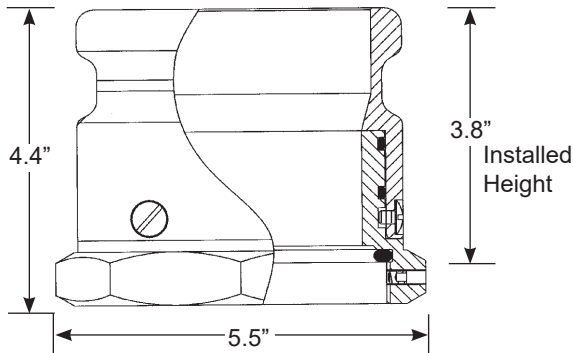

A0030-124S Swivel Fill Adapter

A0030-124SE - Nickel Plated

Guide Specification: The Model A0030-124S Swivel Fill Adapter typically installs on the tank fill riser of a dual point phase I vapor recovery system for underground fuel storage tanks. The top of the adapter rotates 360 degrees in either direction during routine fuel deliveries. The base of the adapter is stationary preventing accidental loosening from the tank fill riser thread connection while eliminating potential vapor leaks and damage to the drop tube. The adapter is designed for use with Top-Seal type fill caps. The A0030-124S is CARB EVR approved and complies with EPA Regulation 40 CFR Part 63. The adapter comes standard with a flat gasket seal and a 4-inch NPSM thread connection. The adapter allows for field serviceability. Weight 8.0 lbs.

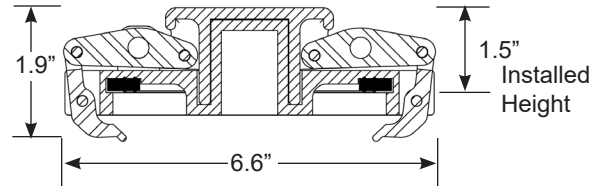

Guide Specification: The Model A0097-005 Fill Adapter Cap is designed for use with Top-Seal type adapters eliminating fuel evaporation and vapor fugitive emissions from escaping into the atmosphere. A lockable aluminum cap handle, self-aligning and toggle action center collar design prevents breakage. Aluminum body power coated gray color for proper field identification. Weight 1.6 lbs.

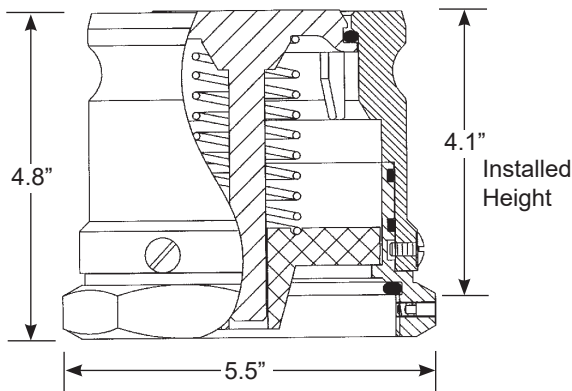

A0076-124S Swivel Vapor Adapter

A0076-124SE - Nickel Plated

Guide Specification: The Model A0076-124S Swivel Vapor Adapter typically installs on the tank vapor riser of a dual point phase I vapor recovery system for underground fuel storage tanks. The top of the adapter rotates 360 degrees in either direction during routine fuel deliveries. The base of the adapter is stationary preventing accidental loosening from the tank vapor riser thread connection while eliminating potential vapor leaks. A normally closed poppet valve opens to recover the vapor during routine fuel deliveries. The adapter is designed for use with Top-Seal type vapor caps. The A0076-124S is CARB EVR approved and complies with EPA Regulation 40 CFR Part 63. The adapter comes standard with a flat gasket seal and a 4-inch NPSM thread connection. The adapter allows for field serviceability. Weight 8.8 lbs.

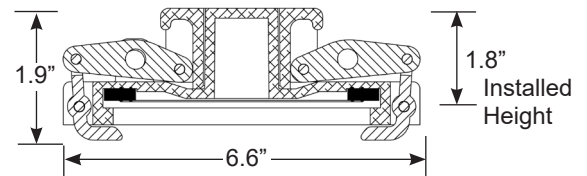

Guide Specification: The Model A0099-002 Vapor Adapter Cap is designed for use with Top-Seal type adapters eliminating fuel evaporation and vapor fugitive emissions from escaping into the atmosphere. A lockable aluminum cap handle, self-aligning and toggle action center collar design prevents breakage. Aluminum body power coated orange color for proper field identification. The Model A0099-003 includes a 12-inch chain to prevent loss or theft. Weight 1.4 lbs.

Service Repair Kits:

494301 O-ring Replacement Kit (2 per)
569924 Gasket Replacement Kit

Service Tool Required:

A0081-001 Adapter Wrench

Certification & Listing:

EPA 40 CFR Part 63

CARB EVR Executive Orders: VR-104, VR-105
A0030-124S, A0076-124S