

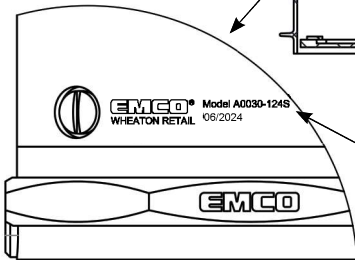

# A0030-124S

## Swivel Fill Adapter

### INSTALLATION INSTRUCTIONS

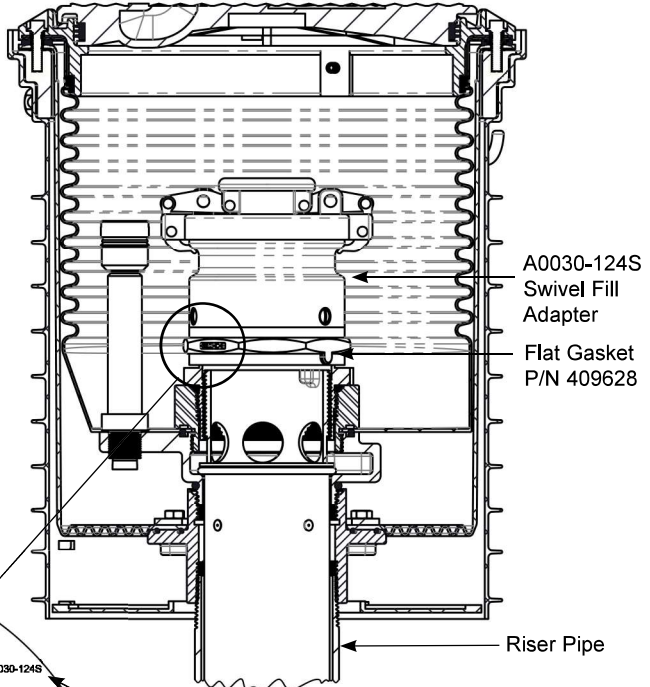

#### **Permanent Identification:**

Model #  
Month/Year of Manufacture

#### **Service Tools Required:**

- Ratchet Wrench
- EMCO Adapter Wrench P/N A0081-001
- EMCO Swivel Adapter Torque Wrench P/N 494240
- 13/16" Socket
- Torque Wrench w/ 60 to 75 ft-lbs Setting

#### **CAUTION:**

Always barricade to keep pedestrians and vehicles from accessing the storage tank area during preventive maintenance and/or compliance testing of the EMCO Phase I EVR system.

#### **ATTENTION:**

Barricader de toujours garder les piétons et les véhicules d'accéder à la zone de stockage lors de la maintenance préventive et/ou des tests de conformité de la Phase EMCO système je EVR.

1. Before installing the A0030-124S swivel fill adapter verify the flat gasket is secured in place. Manually tighten the A0030-124S swivel fill adapter onto the 494096 riser seal to avoid cross threading. Using the EMCO Adapter Wrench P/N A0081-001, tighten and torque between 60 to 75 ft-lbs.

**IMPORTANT: Do not use pipe thread sealant compound when installing the A0030-124S swivel fill adapter onto the 494096 riser seal.**

**IMPORTANT: Ne pas utiliser un tuyau fil composé d'étanchéité lors de l'installation du A0030-124S pivotant adaptateur de remplissage sur le joint de la colonne montante 494096.**

## PREVENTIVE MAINTENANCE

### Static Torque Test:

1. Using the EMCO Swivel Adapter Torque Wrench P/N 494240, annually verify the static torque of the A0030-124S swivel fill adapter by performing ARB test procedure TP-201.1B.
2. If the A0030-124S swivel fill adapter fails to pass the static torque test, replace both O-rings with EMCO O-ring kit P/N 494301.

### Leak Tightness Integrity Test:

1. Annually verify leak tightness integrity of the A0030-124S swivel fill adapter by performing ARB test procedure TP-201.1D.
2. If the A0030-124S swivel fill adapter fails to pass the leak tightness integrity test, replace both O-rings with EMCO O-ring kit P/N 494301 or flat gasket kit P/N 569924.

## PERFORMANCE SPECIFICATIONS

This component was factory tested to, and met, the following specifications.

1. TP-201.1B - Complies with the allowable maximum: 108 in-lbs. average static torque and 360 degrees rotation.
2. Meets ARB Cam and Groove Specifications.

**IMPORTANT: Leave these installation instructions, product warranty registration card and the warranty tag with the station owner and/or operator.**

**IMPORTANT: Laissez ces instructions d'installation, la garantie du produit carte d'enregistrement et l'étiquette de garantie avec le propriétaire de la station et/ou opérateur.**

**Emco Wheaton Retail Corp.**

2300 Industrial Park Dr. • Wilson, NC 27893, 252-243-0150 • 252-243-4759 (fax)

P/N 568396

Rev. N, 11/24