

INSTALLATION INSTRUCTIONS

Permanent Identification:

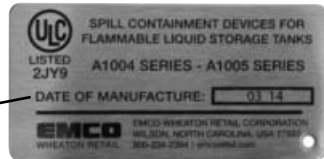

Month/Year of Manufacture



Model #

Model Numbers

A1004EVR-003
A1004EVR-005
A1004EVR-010
A1004EVR-012
A1004EVR-210A
A1004EVR-210AB
A1004EVR-210S
A1004EVR-210SB
A1004EVR-316A
A1004EVR-316S
A1004EVR-316AS
A1004EVR-316SS

Description

Fatboy, Drain Valve, NPT
Fatboy, Drain Valve, BSPT
Slimline, Drain Valve, NPT
Slimline, Drain Valve, BSPT
Single Wall, Drain Valve, NPT
Single Wall, Drain Valve, BSPT
Double Wall, Drain Valve, NPT
Double Wall, Drain Valve, BSPT
Single Wall, Drain Valve, NPT
Double Wall, Drain Valve, NPT
Single Wall, Drain Valve, NPT
Double Wall, Drain Valve, NPT

Required Service Tools:

- Tape Measure
- Torque Wrench w/ 15 ft-lbs. Setting
- Pipe Thread Sealant Compound
- EMCO Spill Containment Wrench p/n A0081-001H Wrench
- Torque Wrench w/ 100 to 150 ft-lbs. Setting
- Ratchet
- 1/2" Socket
- 1/2" Crows Foot
- 3/4" Socket
- 1/2" Hand Wrench

***Must use A0081-001H Wrench for installation. Maximum torque: 150 lbs*ft. Do not exceed max torque or twist rim to tighten, as damage may occur.**

CAUTION:

1. Always barricade to keep pedestrians and vehicles from accessing the storage tank area during preventive maintenance and/ or compliance testing of the EMCO phase I EVR system.

Sizing the Riser Pipe

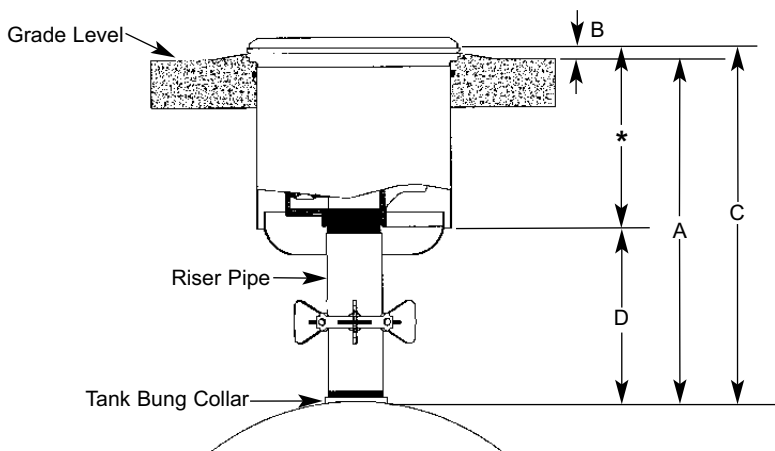

1. Find measurement A, the distance between grade level to the top of the tank bung collar.
2. Find measurement C, by adding measurement A to measurement B, the crown height.

EXAMPLE: Measurement C equals Measurement A, plus Measurement B, the crown height.

IMPORTANT: Crown height must be a minimum of 1 inch for proper water run-off.

3. The height of the A1004EVR spill containment varies between single wall and double wall configurations, refer below for proper height specifications.

<u>Model Number</u>	<u>Spill Containment</u>	<u>*Install Height (inches)</u>
A1004EVR-003	Fatboy	13.8
A1004EVR-005	Fatboy	13.8
A1004EVR-010	Slimline	13.6
A1004EVR-012	Slimline	13.6
A1004EVR-210A	Single Wall	14.3
A1004EVR-210S	Double Wall	18.8
A1004EVR-316A	Single Wall	15.0
A1004EVR-316S	Double Wall	17.1
A1004EVR-316AS	Single Wall	12.9
A1004EVR-316SS	Double Wall	15.0

IMPORTANT: Do not remove the factory installed jack assembly or stabilizer bars until the concrete has set. Failure to do so will change the factory set height of the A1004EVR spill containment causing an improper installation.

4. Find measurement D, by subtracting the install height of the A1004EVR spill containment from measurement C, then add 1.0 inch for the riser pipe threads.
5. After properly sizing the 4-inch diameter riser pipe, cut threads to either NPT or BSPT standards. Use a non-hardening gasoline resistant pipe thread sealant compound before installing the 4-inch diameter riser pipe to the tank bung collar.

IMPORTANT: Do not use hacksaw to cut riser pipe.

Installation Example for the A1004EVR-210A Spill Containment

1. The tank burial is 36 inches from grade level to the top of the tank bung collar. Measurement A equals 36 inches.
2. The site installation requires a 1-inch crown height for proper water run-off. Measurement B is 1 inch. Add measurement A 36 inches, to measurement B, 1 inch, equals measurement C, 37 inches.
3. The height of the **A1004EVR-210A single wall spill containment** is 14.3 inches. Subtract the height of 14.3 inches from measurement C, 37 inches, then add 1 inch for the riser pipe threads.
4. The required length for the 4-inch diameter riser pipe is measurement D, 23.7 inches.

IMPORTANT: The riser pipe must be sized to the correct length before attempting to install the A1004EVR spill containment. Do not over stretch the spill containment bellows to compensate for an under sized or poorly cut riser pipe. Failure to do so will result in damage to the spill containment causing a possible fuel leak into the backfill, and/ or void warranty.

Riser Lock to Riser Pipe

A0028 Riser Lock

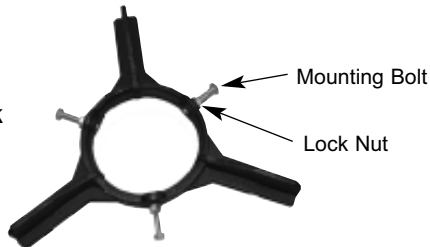

IMPORTANT: All single wall and double wall configurations come standard from the factory with an A0028 riser lock. The purpose of the A0028 riser lock is to prevent the riser pipe from turning during subsequent removal and installation of the primary liner.

1. Before attempting to install the A0028 riser lock onto the riser pipe, loosen all mounting bolts and lock nuts using a 1/2" hand wrench.
2. Install the A0028 riser lock over the top of the riser pipe. Slide the A0028 riser lock downward until resting on the backfill or top of tank.
3. Install the gravel pan over the top of the riser pipe. Slide the gravel pan downward until resting on the A0028 riser lock.

Spill Containment to Riser Pipe

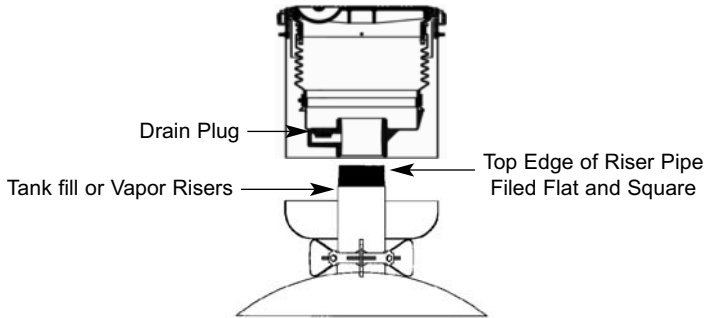

1. Before installing the A1004EVR spill containment, the top edge of the riser pipe must be filed flat and square to insure a proper sealing surface between the riser pipe and base of the 1004EVR spill containment.

IMPORTANT: The A1004EVR spill containment comes with a factory installed non-removal drain plug, and is CARB EVR approved for use on the tank fill or vapor risers.

2. Apply a non-hardening gasoline resistant pipe thread sealant compound to the threads of the riser pipe. Manually tighten the A1004EVR spill containment onto the riser pipe to avoid cross threading. Use the EMCO Spill Containment Wrench p/n A0081-001H to tighten and torque the A1004EVR spill containment between 100 and 150 ft-lbs.
3. Lift the gravel pan up and touching the bottom of the spill container. Use duct tape to secure it.
4. Position the riser lock halfway between tank top and bottom of the spill containment and tighten bolts.

A1004EVR Spill Containment Backfill and Concrete Finish

1. Complete the backfill over the tank and around the gravel guard of the A1004EVR spill containment. Be sure the height of the backfill meets the depth requirements for the concrete pad.
2. Concrete must completely fill around and under the A1004EVR spill containment rim to insure proper anchoring.
3. Before the concrete sets remove all excess concrete from the top of A1004EVR spill containment rim and water run-off channels.

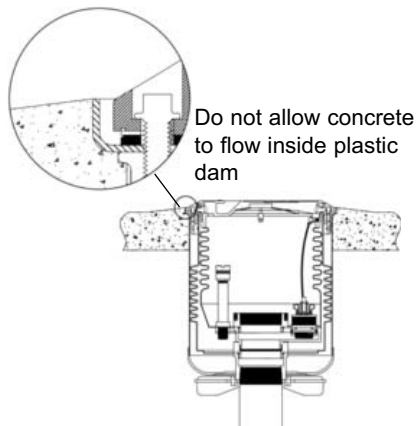

IMPORTANT: Crown height must be a minimum of 1 inch for proper water run-off.

Removing the Jack Assembly or Spacer Bars

1. Once the concrete has set, remove the factory installed jack assembly or spacer bars from the inside of the A1004EVR spill containment:
 - Models A1004EVR-003, 005, 010 and 012 - Remove the 3 spacer bars and dispose.
 - Models A1004EVR-210 - Use a $\frac{3}{4}$ " socket and ratchet wrench to turn the adjustment bolt counter clockwise to loosen. Swing the top cross bar away from the inside edge of the rim and dispose.
 - Models A1004EVR-316A and -316S - Remove the cotter pin from the top of each jack, and slide the bracket off of the clevis. The unthreaded bolt and bottom brackets will remain in place. Dispose of the cotter pins, jacks, brackets, clevis and bolts.
 - Models A1004EVR-316AS and -316SS – Do not come with factory installed spacer bars or jack assemblies. The spill containment height is fixed.
2. Clean and remove all debris from the inside of the A1004EVR spill containment, drain valve and filter.
3. Paint the A1004EVR spill containment rim and lid to the desired fuel grade color code.

Refer to attached TP-160 Test Procedures.

Spill Containment with Overfill Prevention Valve or Straight Drop Tube, Riser Seal, Swivel Fill Adapter and Fill Adapter Cap

1. When installing the A1004EVR spill containment with an Emco Wheaton overfill prevention valve, please refer to the A1100EVR installation instructions.
2. When installing the A1004EVR spill containment with an Emco Wheaton straight drop tube, please refer to the A0020EVR and A0020EVRC installation instructions.

IMPORTANT: The tank fill riser installation will only allow for one type of EVR drop tube configuration.

3. When installing the A1004EVR spill containment with an Emco Wheaton riser seal, please refer to the 494096 installation instructions.
4. When installing the A1004EVR spill containment with an Emco Wheaton swivel fill adapter, please refer to the A0030-124S installation instructions.
5. When installing the A1004EVR spill containment with an Emco Wheaton fill adapter cap, please refer to the A0097 installation instructions.

PREVENTIVE MAINTENANCE

1. Quarterly verify that the inside of the A1004EVR spill containment is free of all dirt, gravel, debris, etc. Should cleaning be required, wipe the inside wall and bottom of the A1004EVR spill containment using soapy water and disposable towels.
2. After each delivery, the station operator must remove any standing fuel from the inside of the A1004EVR spill containment. If gasoline does not drain, refer to the #494118 drain valve preventive maintenance instructions.

IMPORTANT: During routine preventive maintenance all damaged components must be replaced with factory authorized service kits.

Service Repair Kits

<u>Part Number</u>	<u>Description</u>
• 494118	Drain Valve Kit
• 494360EVR	-210A Primary Repair Kit
• 494350EVR	-210S Primary Repair Kit
• 494797EVR	-316A Primary Repair Kit
• 494794EVR	-316S Primary Repair Kit
• 495392EVR	-316AS Primary Repair Kit
• 495393EVR	-316SS Primary Repair Kit
• 495067K	Vent Valve Replacement Kit
• 495625	EZ-Gage O-ring Kit
• 566332	Lid and Seal -003 Series
• 570012	Triple Wiper Seal, A1004-316CLID
• A1004-210LID	Lid and Seal -211 and -011 Series
• A1004-316CLID	Lid and Seal -317 Series
• A1004-210TEST	Vacuum Test Apparatus
• A1004-210GAGE	Interstitial Gauge
• A1004-316LID	Lid and Seal Composite

PERFORMANCE SPECIFICATIONS

This component was factory tested to, and met, the following specifications.

1. TP-201.1D - Complies with the allowable maximum leakrate of 0.17 CFH @ 2.00 inches of water.

IMPORTANT: Leave these installation instructions, product warranty registration card and the warranty tag with the station owner and/or operator.

IMPORTANT: Tank Operator Responsibilities

- Tank operator must ensure that all Federal, Provincial and local codes are being met during the filling of the tank.
- All operators must be familiar with proper filling procedures.
- The operator responsible for transferring product to an above ground storage tank must take all reasonable steps to prevent spillage.
- The delivery hose from the tank's fill pipe must not be disconnected before the hose has been drained completely.
- When tank vehicles are being unloaded, the vehicle operators must remain:
 - (a) in constant view of the transfer nozzle and fill pipe; and
 - (b) in constant attendance at the discharge control valve.

Emco Wheaton Retail Corp.

2300 Industrial Park Dr. • Wilson, NC 27893
252-243-0150 • 252-243-4759 (fax)

p/n 569833
Rev. AB 06/18