



A1005-505C Series

Stainless Steel Spill Containment

Replacement for OPW 2100C Standard

INSTALLATION INSTRUCTIONS

US Patents 8,425,145 B2
and 8,425,145 B

Emco Supplied Parts

Stainless steel bucket
O-ring
(2) split flanges
(10) stainless steel bolts
Lid w/seal

Required Kits

Pipe nipple (see chart below)
If existing bucket has a drain...
A1005-505DP Drain Plug Kit *or*
A1005-505DPE Drain Plug Kit
w/epoxy

Required Tools

Hammer and chisel
9/16" socket
1/2" socket
12" extension and ratchet
Chain wrench or strap wrench
Pipe sealant
Urethane sealant
(such as Emco Z0839-001)
Adapter wrench
Wire brush
Plumbers putty or heavy grease

Purchased Separately from Emco

Emco 494833 Test Cover
Emco A1004-210TEST

Refer to your local regulations and AHJ before installation of this product

Step 1: Measure Dimension A as shown on the drawing below. Measure from the drain channel to the bottom of the existing bucket. Write the dimension down. *This dimension must be greater than 12 1/8" for the Emco stainless steel liner to work.*

Step 2: Measure Dimension B from inside the rim (see drawing below) to the top of the existing nipple. This dimension must be greater than 6 3/4" for a vapor application and 6 1/4" for a fill application. If the dimensions are less than specified, an alternative nipple will be required. The proper nipple can be selected from the table below. The requirements of step 3 must also be met before proceeding with the existing nipple.

Step 3: Measure from the drain channel down 9 1/16". At this dimension, you must have a clean pipe surface on the nipple. You can not have threads in this area. This is where the o-ring will seal, and the o-ring will not seal on pipe threads. If you do not have a clean, undamaged, and unthreaded pipe nipple surface at this dimension (9 1/16"), a new clean and undamaged nipple will be required. The proper nipple can be selected from the table below.

Step 4: Select proper nipple, if required, from step 2 or 3.

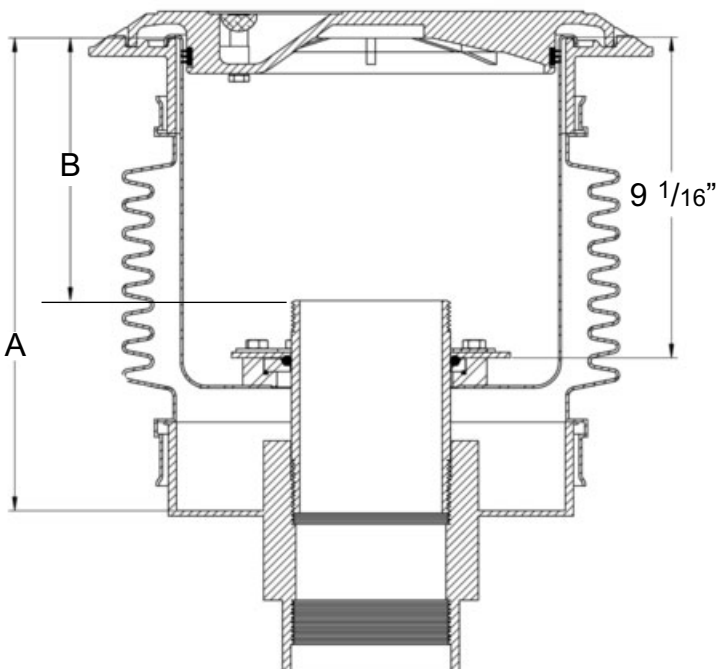

Pipe Nipple Selection Chart	
<u>Dimension A, Bucket Depth:</u> Drain Channel to Bottom of Bucket	Nipple Requirement
12 1/8" - 13 1/4"	Emco A7901-006
13 1/4" - 14 1/4"	Emco A7901-007
14 1/4" - 15 1/4"	Emco A7901-008
15 1/4" - 16 1/4"	Emco A7901-009
16 1/4" - 17 1/4"	Emco A7901-010



A1005-505C Series

Stainless Steel Spill Containment



Step 5: Using a chisel and hammer, remove cast iron lugs from the OPW bucket, leaving the inside of the rim smooth. Care should be taken not to break the rim.

Step 6: Test fit the stainless steel bucket in the existing spill bucket to ensure rim clearance. If a drain exists, the stainless steel bucket may not go down completely. This step is to ensure bucket clears remnants of rim tabs only. If necessary, chisel clearance in the rim where the cast iron lugs were located.



Step 7: Remove existing pipe nipple. Clean with a wire brush. Use a chain wrench to re-install the nipple, or a new nipple if required. Avoid scarring the seal surface. (If seal surface is damaged, the unit will not pass pressure decay test.) Use pipe sealant on the lower threads. Repeat steps 2 and 3 to insure proper nipple selection.



Step 8: Using a 1/2" socket, remove the drain, if existing. Carefully inspect the drain cavity to ensure there is no damage that could cause the bucket to fail testing requirements.



Step 9: Plug the drain cavity using Emco A1005-505DP or A1005-505DPE (w/ epoxy) Drain Plug Kit, following instructions included with kit. If using A1005-505DPE, insert drain plug (included in kit) into drain channel to prevent flow of epoxy.



Step 10: Test fit the new stainless steel bucket to ensure that it sits completely flat on the top of the rim surface, then remove the stainless steel bucket.



A1005-505C Series Stainless Steel Spill Containment



Step 11: Thoroughly clean the existing rim surface with a wire brush, then with a solvent such as lacquer thinner to ensure there is no oily residue on the rim. A bead of urethane sealant, placed on the underside cavity of the new bucket, may be used to prevent groundwater from entering the existing containment.



Step 12: Install the new stainless steel bucket over the nipple, pushing it down completely to ensure that it seats fully on the existing rim.



Step 13: Install new o-ring over the nipple, seating it completely in the groove in the stainless steel flange.



Step 14: Install the two split flanges using the ten supplied stainless steel bolts. Hand tighten all ten bolts, ensuring that the bucket is completely down and flat on the rim.



Step 15: Using a 9/16" socket, tighten each of the ten bolts to 15 ft. lbs. Pressure may need to be applied to ensure the liner does not shift while tightening bolts.



Step 16: Install adapter and cap per instructions included with each.

Step 17: Testing

Perform one of the following test procedures as specified by customer:

Integrity Test - perform per following procedure, with customer specified cap and adapter.

Hydrostatic Test - perform if specified per customer or local regulations. Perform per local guidelines.



A1005-505C Series Stainless Steel Spill Containment

Integrity Test Procedure

Equipment (not supplied)

Emco A1004-210TEST Vacuum Apparatus w/test adapter 494343

Emco 494833 Test Cover

Timer

Air supply

Procedure

1. Line top surface of stainless steel bucket with plumbers putty. (Heavy grease may be used, but may not work properly on rough surfaces.)
2. Place test cover over plumbers putty or heavy grease.
3. Insert brass plug from test unit into opening in test cover (A).
4. Attach air pressure source to air pressure regulator on vacuum apparatus.
5. Slowly apply vacuum of 30" water column (2.2" mercury) to the interstitial space, by moving the toggle switch. Wait 30 seconds. Reapply 30" water column.
6. Ensure switch is in off (center) position, start timer and record remaining vacuum after 1 minute.
7. If the remaining vacuum after 1 minute is 26" water column (1.9" mercury) or greater, the containment is tight.
8. If the test fails, determine if leak point is at test cover seal, cap or adapter, or base flange o-ring by spraying a soap solution to each area and watching for bubbles. Repair as required and retest.
9. Replace components.

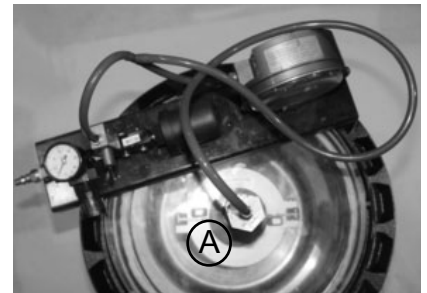

Follow-Up Testing

If follow-up or annual retesting is required by local/state regulation, use the above procedure.

Tank Operator Responsibilities

Tank operator must ensure that all Federal, Provincial and local codes are being met during the filling of the tank.

All operators must be familiar with proper filling procedures.

The operator responsible for transferring product to an above ground storage tank must take all reasonable steps to prevent spillage.

The delivery hose from the tank's fill pipe must not be disconnected before the hose has been drained completely.

When tank vehicles are being unloaded, the vehicle operators must remain

- (a) in constant view of the transfer nozzle and fill pipe; and
- (b) in constant attendance at the discharge control valve.

Emco Wheaton Retail

2300 Industrial Park Dr. • Wilson, NC 27893 252-243-0150 • 252-243-4759 (fax)