

IMPORTANT

Read these instructions completely before attempting to install this system. Failure to follow these instructions could result in damage to the manhole or tank and will void any warranty. Installation of the A1005 manhole on risers other than 4" NPT or use of equipment other than Emco Wheaton Retail could require modifications. Prior to any modifications or if you have any questions, please call Emco Wheaton Retail Customer Service at 800-234-4394.

INSTALLATION INSTRUCTIONS

Step 1 Tank Riser Pipe Length

1. Measure from top of tank bushing to grade = length A (Figure 1).
2. Add crown height, length B to length A = length C.
Note: Length B should be 1" minimum for proper run-off.
3. Manhole height = 12.8"
4. Subtract manhole height, 12.8" from length C = distance between the tank bushing and manhole body, length D.
5. Cut and finish riser pipe to length D plus .5". Thread riser pipe to 4.00 - 8 NPT requirements.
6. Tighten riser pipe/tank joint using a permanent thread lock sealant.

Example

1. A buried tank measures 36" from the top of the tank bushing to grade level. Length A is 36".
2. The site requires 1" crown above grade to manhole rim for water run-off. Length B is 1".
3. Length A + length B = length C; $36" + 1" = 37"$
4. Length C - 12.8" = length D; $37" - 12.8" = 24.2"$
5. The 4" riser pipe should be $24.2" + .5" = 24.7"$

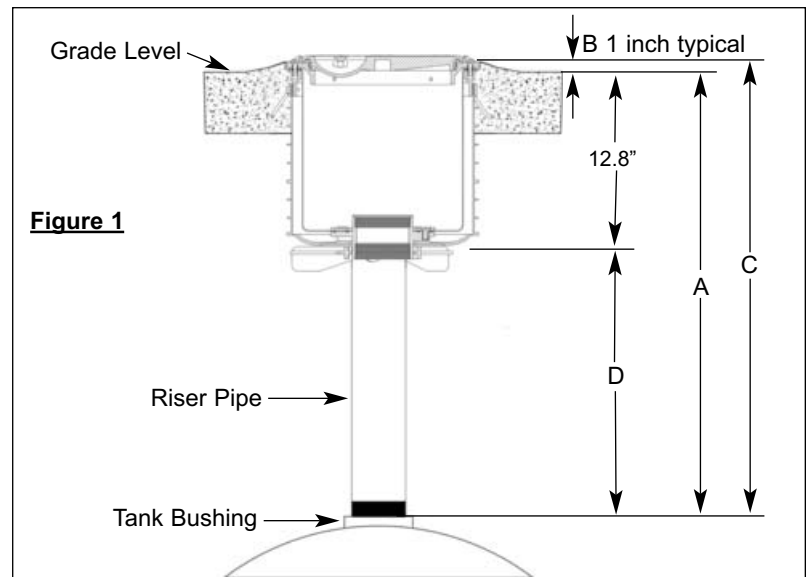

Step 2 Manhole to Riser

1. Tighten manhole to riser joint using a thread sealant such as Emco Wheaton Z0838. Using the Emco A0081-001H Wrench, tighten the manhole onto the riser pipe until snug.

Caution: Excessive tightening of the manhole may result in damage to the manhole which may cause leakage.

Step 3 Cap and Adapter

1. After installing drop tube or overflow prevention valve, install adapter and cap as per manufacturer's instructions.
2. Replace lid on manhole.

Step 4 Hydrostatic Testing - perform per local requirements

Step 5 Integrity Testing - below

Step 6 Backfill and Finish

1. Finish back filling over tank and around manhole to depth required for concrete pad.
2. Concrete must completely fill around and under manhole rim to insure proper anchoring.
3. After concrete has set, remove excess concrete from inside of rim and the runoff channels.
4. Paint lid as required by product color code.

Maintenance

1. Keep rim/lid and drain areas free of debris.
2. Replace any damaged part at once.

Integrity Test Procedure

Equipment (not supplied)

Emco A1004-210TEST Vacuum Apparatus w/test adapter 494343

Emco 494833 Test Cover

Timer

Air supply

Procedure

1. Line top surface of stainless steel bucket with plumbers putty.
(Heavy grease may be used, but may not work properly on rough surfaces.)
2. Place test cover over plumbers putty or heavy grease.
3. Insert brass plug from test unit into opening in test cover (A).
4. Attach air pressure source to air pressure regulator on vacuum apparatus.
5. Slowly apply vacuum of 30" water column (2.2" mercury) to the interstitial space, by moving the toggle switch. Wait 30 seconds. Reapply 30" water column.
6. Ensure switch is in off (center) position, start timer and record remaining vacuum after 1 minute.
7. If the remaining vacuum after 1 minute is 26" water column (1.9" mercury) or greater, the containment is tight.
8. If the test fails, determine if leak point is at test cover seal, cap or adapter, or base flange o-ring by spraying a soap solution to each area and watching for bubbles. Repair as required and retest.
9. Replace components.

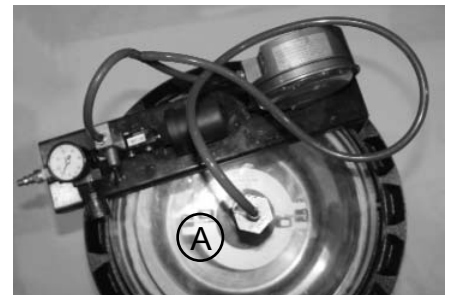

Follow-Up Testing

If follow-up or annual retesting is required by local/state regulation, use the above procedure.

Tank Operator Responsibilities

1. Tank operator must ensure that all Federal, Provincial and local codes are being met during the filling of the tank.
2. All operators must be familiar with proper filling procedures.
3. The operator responsible for transferring product to an above ground storage tank must take all reasonable steps to prevent spillage.
4. The delivery hose from the tank's fill pipe must not be disconnected before the hose has been drained completely.
5. When tank vehicles are being unloaded, the vehicle operators must remain (a) in constant view of the transfer nozzle and fill pipe; and (b) in constant attendance at the discharge control valve.