



# A1005-518R Series

## Retrofit Double Wall Poly Secondary/Stainless Steel Primary

### INSTALLATION INSTRUCTIONS

#### Required Tools:

1/2" or 9/16" Socket Wrench  
3/8" Socket  
3/8" Allen Wrench  
Wire Brush  
Putty Knife  
Emco A0081-001H Wrench  
Emco A0081-001R Retrofit Lid Wrench  
Razor Knife  
Tape Measure  
Pipe Sealant

**Step 1:** Remove existing lid, cap, adapter and OPV or drop tube. Cover or "ball" the riser pipe to prevent debris from entering the tank. Measure the approximate dimension from grade to existing riser pipe (as noted in Step 6), to insure the dimension is **at least 14 1/4"**.

If dimension is less than 14 1/4", order p/n 570522H which will allow the installation with a minimum eight of 12 3/4". At the minimum of 12 3/4", a low profile cap will be required. A shorter extension (A7901-305K) may also be used. The original insert can be returned to Emco for credit. Note that this is an unusual occurrence, less than 5% of total installations.

**Measure from the bucket nipple to the tank bottom**, and record this length for use in step 13. (This measurement is used to determine if the existing OPV or drop tube can be reused.)

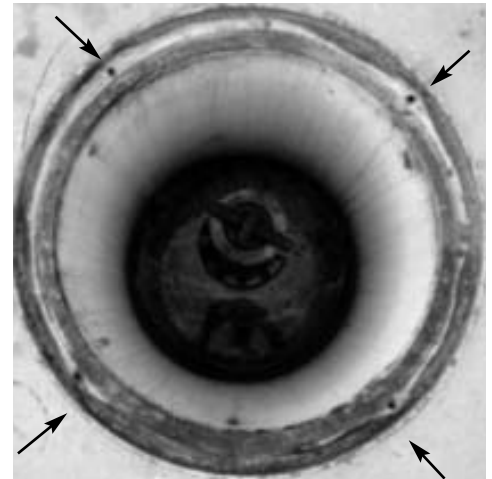
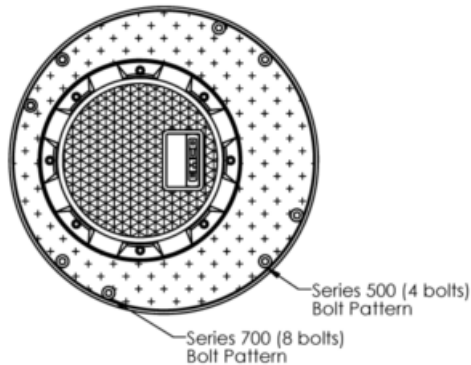

Series 500 (4 bolts) Bolt Pattern



**Step 2:** Remove the 4 nuts from underneath the primary rim to loosen. Remove rim. Remove bolts from diamond plate lid, and remove lid.



**Step 3:** Use the Emco A0081-001H Wrench to remove the existing primary. Use of the A0081 Wrench will avoid slipping of the existing primary and prevent breaking the composite "ears".



**Step 4:** Clean existing rim using a wire brush and putty knife to remove the old gasket and sealants. Blow out bolt holes.



**Step 5:** Check for interferences which would prevent the Emco lid from seating properly. Remove any obstructions and install 571964 Rim Seal (included with A1005-518RS variants).



# A1005-518R Series

## Retrofit Double Wall

### Poly Secondary/Stainless Steel Primary

**Step 6:** Measure from the top of the existing OPW bucket to the top of the riser pipe. Use pipe sealant on internal and external threads of riser extensions and install as required to achieve the required height of 14<sup>1</sup>/<sub>4</sub>" - 16<sup>3</sup>/<sub>4</sub>". A combination of riser extensions or a coupling and nipple should be used as required to meet the 16<sup>3</sup>/<sub>4</sub>" maximum dimension. Some OPW buckets used 7<sup>1</sup>/<sub>2</sub> gallon primaries that would require a longer nipple to achieve the dimension required.

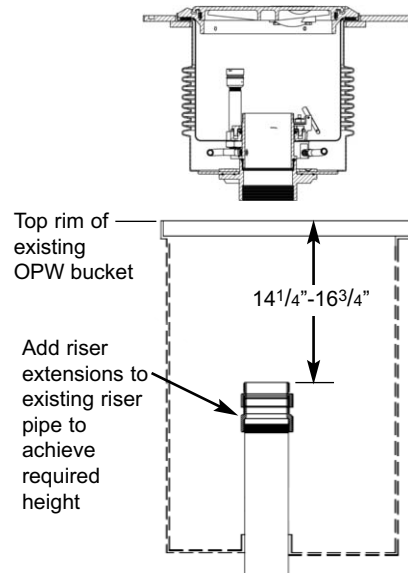

**Step 7:** Thread the new assembly onto the riser pipe and hand tighten. If the base of assembly is touching existing rim before it starts getting tight, use the jacks to raise the assembly by turning 3 turns counter-clockwise. Continue tightening the assembly by hand.

**Step 8:** Use the Emco A0081-001R Retrofit Lid Wrench to tighten bucket onto riser. As the bucket tightens, align outside of lid and one of the two 4-hole bolt patterns in the lid, with four of the existing holes tapped in the rim, (refer to drawing on front page to determine which bolt pattern to use), so that the lid can drop into existing rim.



**Step 9:** Release the jack by turning clockwise until loose. Make sure that the flange o-ring has a smooth (not threaded) surface to seal on. This can be a problem if the bucket is overextended for a deep installation. If this happens, an additional riser extension is needed to correct the riser length.

**Step 10:** Align the (4) bolt holes and install the (4) 5/16 x 3/4 bolts (OPW 500) or (4) 3/8 x 3/4 bolts (OPW 700).



Note: In some cases it may be necessary to unbolt the rim from the lid and rotate the lid into a position where it will drop into existing rim. Re-align bolt holes in rim, lid and existing rim and reassemble.

**Step 11:** Use a 9/16" socket to tighten the 9 bolts on the flange at the bottom of the stainless steel liner to 15 ft. lbs. Note that the flange bolts must be tightened for the interstitial space to pass leak testing.



**Step 12:** Install four threaded plugs using a 3/8" Allen Wrench into unused bolt pattern.



# A1005-518R Series

## Retrofit Double Wall

### Poly Secondary/Stainless Steel Primary

**Step 13:** Measure the distance from the nipple to the tank bottom, and compare with the original measurement from Step 1. If the dimension is more than 1/2" different, measure the overfill prevention valve (OPV) or drop tube length. Subtract the OPV length from the current riser to tank dimension. It is important to measure the OPV or drop tube, and the depth of the tank from the bucket nipple. The riser pipe must be 4-6" from the tank bottom. If it is less than 4", it can cause OPV or flow problems. EPA regulations prohibit greater than 6". If the riser pipe is greater than 6", a new OPV or drop tube should be installed. If the riser pipe is closer than 4" to the bottom, it should be cut so the dimension is 4-6". Reinstall the OPV or drop tube, adapter, cap and spill containment lid.

**Step 14:** Perform hydrostatic test as per local requirements.

**Step 15:** Perform secondary integrity test - attached.





# A1005-518R Series

## Retrofit Double Wall

### Poly Secondary/Stainless Steel Primary

## Secondary Integrity Test

Emco Wheaton Retail A1004-210S Double Wall Spill Containment are vacuum tested, both primary and secondary, prior to shipment. To ensure that no damage has incurred during shipment or installation, the following test is a quick, on-site method to verify the integrity of the primary and secondary containments.

### Equipment

Vacuum apparatus w/test adapter 494343, available from Emco Wheaton Retail, p/n A1004-210TEST

Timer

Air supply, 30 psi

### Procedure

1. Remove the dipstick from the inspection port and install the test adapter p/n 494343 (included with the vacuum apparatus) (A).
2. Attach air pressure source to air pressure regulator (B) on vacuum apparatus.
3. Slowly apply vacuum of 30" water column to the interstitial space, by moving the toggle switch (C). Wait 30 seconds. Reapply 30" water column.
4. Ensure switch is in off (center) position, start timer and record remaining vacuum after 1 minute.
5. If the remaining vacuum after 1 minute is 26" water column (1.9" mercury) or greater, both the primary and the secondary containment vessels are tight.
6. If the test fails, allow the bellows to equalize for one minute and repeat test, starting at step 3.
7. If test fails a second time, refer to Emco Wheaton Retail Test Procedures TP-160 and TP-161.
8. Replace components or repair as necessary.

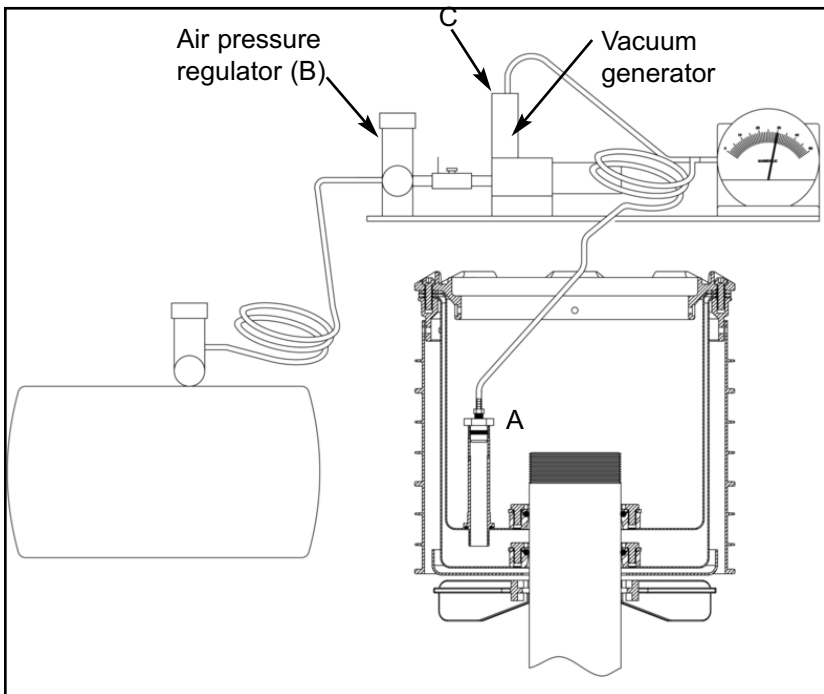

### Maintenance

1. Keep rim/lid and drain areas free of debris.
2. Replace any damaged part at once.

### Replacement Items

494343	Test Adapter
A1004-001GAGE	EZ gauge
A1004-210TEST	Vacuum Test Apparatus
A1004-316CLID	Lid and Seal



494343 Test Adapter

### Tank Operator Responsibilities

1. Tank operator must ensure that all Federal, Provincial and local codes are being met during the filling of the tank.
2. All operators must be familiar with proper filling procedures.
3. The operator responsible for transferring product to an above ground storage tank must take all reasonable steps to prevent spillage.
4. The delivery hose from the tank's fill pipe must not be disconnected before the hose has been drained completely.
5. When tank vehicles are being unloaded, the vehicle operators must remain (a) in constant view of the transfer nozzle and fill pipe; and (b) in constant attendance at the discharge control valve.

Emco Wheaton Retail

2300 Industrial Park Dr. • Wilson, NC 27893 252-243-0150 • 252-243-4759 (fax)

p/n 570906  
08/18 Rev. H