



A1005-505CE15

Stainless Steel Spill Containment Replacement for EBW 715, 725

INSTALLATION INSTRUCTIONS

US Patents 8,425,145 B2
and 8,425,145 B

Refer to your local regulations and AHJ before installation of this product

Emco Supplied Parts

- Stainless steel bucket
- Eccentric ring
- (2) O-rings
- (3) split flanges
- (9) stainless steel bolts
- (9) washers
- Lid w/seal

Required Kits

- Pipe nipple (see chart below)
- If existing bucket has a drain...*
A1005-505DPEB Drain Plug Kit

Required Tools

- 3/16" Allen wrench
- 9/16" socket
- 1/2" socket
- 12" extension and ratchet
- Chain wrench or strap wrench
- Pipe sealant
- Urethane sealant
(such as Emco Z0839-001)
- Adapter wrench
- Wire brush
- Plumbers putty or heavy grease

Purchased Separately from Emco

- Emco 494833 Test Cover
- Emco A1004-210TEST

Step 1: Measure Dimension A as shown on the attached drawing. Measure from the existing drain channel to the bottom of the existing bucket. Write the dimension down. *This dimension must be 17" or greater for the Emco stainless steel liner to work.*

Step 2: Measure Dimension B from inside the rim (see drawing below) to the top of the existing nipple. This dimension must be greater than 6 3/4" for a Vapor application and 6 1/4" for a Fill application. If the dimensions are less than specified an alternative nipple will be required. The proper nipple can be selected from the table below. The requirements of step 3 must be met also before proceeding with the existing nipple.

Step 3: Measure from the Drain Channel down 15". At this dimension, you must have a clean pipe surface on the nipple. You can not have threads in this area. This is where the o-ring will seal, and the o-ring will not seal on pipe threads. If you do not have a clean, undamaged, and unthreaded pipe nipple surface at this dimension (15") then a new clean and undamaged nipple will be required. The proper nipple can be selected from the table below.

Step 4: Select proper nipple if required from step 2 or 3. Remove existing pipe nipple and install new pipe nipple. Repeat steps 2 and 3 to insure proper nipple selection.

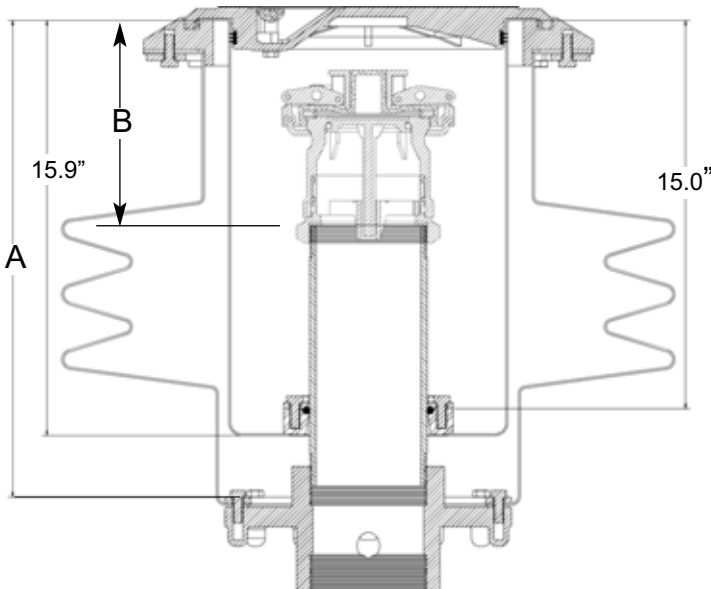

Pipe Nipple Selection Chart	
Dimension A, Bucket Depth: Drain Channel to Bottom of Bucket	Nipple Requirement
Fill Bucket	
17 1/8" - 21"	Emco A7901-010
21" - 23"	Emco A7901-012
23" - 24"	Emco A7901-013
24" - 26"	Emco A7901-015



Step 5: Remove existing pipe nipple. Clean with a wire brush. Use a chain wrench to re-install the nipple, or a new nipple if required. Avoid scarring the seal surface. (If seal surface is damaged, the unit will not pass pressure decay test.) Use pipe sealant on the lower threads. Repeat steps 2 and 3 to insure proper nipple selection.



Step 6: Using a 3/16" Allen wrench, remove the drain, if existing. Take care when removing bolts as there is Loc-tite on the threads, and the hex on the bolt heads may be subject to stripping. Carefully inspect the drain cavity to ensure there is no damage that could cause the bucket to fail testing requirements. Plug the drain cavity using Emco A1005-505DPEB Drain Plug Kit. Install the gasket, then the stainless steel plate. Use a 1/2" socket to secure in place with new bolts, provided.



Step 7: Test fit the new stainless steel bucket to ensure that it sits completely flat on the top of the rim surface, then remove the stainless steel bucket.



Step 8: Thoroughly clean the existing rim surface with a wire brush, then with a solvent such as lacquer thinner to ensure there is no oily residue on the rim. A bead of urethane sealant, placed on the underside cavity of the new bucket, may be used to prevent groundwater from entering the existing containment.



Step 9: Install the new stainless steel bucket over the nipple, pushing it down completely to ensure that it seats fully on the existing rim.



Step 10: Install the small cross section o-ring in the groove of the lower flange. Make certain o-ring groove is clean and free of debris.

Large section of offset ring
O-ring groove facing up



Step 11: Install the aluminum offset ring, with o-ring groove facing up. Align the large section of the ring with largest open area around the nipple as shown.



Step 12: Install the large cross section o-ring.



Step 13: Install the three flanges using the nine supplied stainless steel bolts and washers. Ensure that the flanges are tight against the nipple.



Step 14: Hand tighten all nine bolts, ensuring that the bucket is completely down and flat on the rim.



Step 15: Using a 9/16" socket, tighten each of the nine bolts to 15 ft. lbs. Pressure may need to be applied to ensure the liner does not shift while tightening bolts.



Step 16: Install adapter and cap per instructions included with each.

Step 17: Testing - Perform one of the following test procedures as specified by customer:

Integrity Test - perform per following procedure, with customer specified cap and adapter.

Hydrostatic Test - perform if specified per customer or local regulations. Perform per local guidelines.

Integrity Test Procedure

Equipment (not supplied)

Emco A1004-210TEST Vacuum Apparatus w/test adapter 494343

Emco 494833 Test Cover

Timer

Air supply

Procedure

1. Line top surface of stainless steel bucket with plumbers putty.
(Heavy grease may be used, but may not work properly on rough surfaces.)
2. Place test cover over plumbers putty or heavy grease.
3. Insert brass plug from test unit into opening in test cover (A).
4. Attach air pressure source to air pressure regulator on vacuum apparatus.
5. Slowly apply vacuum of 30" water column (2.2" mercury) to the interstitial space, by moving the toggle switch. Wait 30 seconds. Reapply 30" water column.
6. Ensure switch is in off (center) position, start timer and record remaining vacuum after 1 minute.
7. If the remaining vacuum after 1 minute is 26" water column (1.9" mercury) or greater, the containment is tight.
8. If the test fails, determine if leak point is at test cover seal, cap or adapter, or base flange o-ring by spraying a soap solution to each area and watching for bubbles. Repair as required and retest.
9. Replace components.

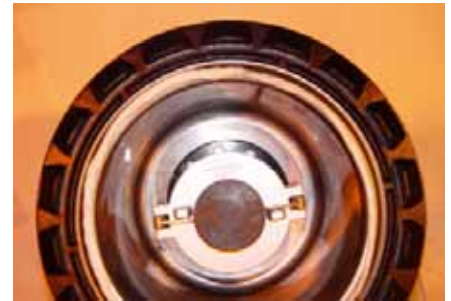

Follow-Up Testing

If follow-up or annual retesting is required by local/state regulation, use the above procedure.

Tank Operator Responsibilities

Tank operator must ensure that all Federal, Provincial and local codes are being met during the filling of the tank.

All operators must be familiar with proper filling procedures.

The operator responsible for transferring product to an above ground storage tank must take all reasonable steps to prevent spillage.

The delivery hose from the tank's fill pipe must not be disconnected before the hose has been drained completely.

When tank vehicles are being unloaded, the vehicle operators must remain

- (a) in constant view of the transfer nozzle and fill pipe; and
- (b) in constant attendance at the discharge control valve.