



# A1004EVR-317SM800/900

Retrofit Double Wall w/Sensor  
Poly Secondary/Stainless Steel Primary

## INSTALLATION INSTRUCTIONS

### Required Tools:

1/2" or 9/16" Socket Wrench  
3/8" Socket  
3/8" Allen Wrench  
Wire Brush  
Putty Knife  
Emco A0081-001H Wrench  
Emco A0081-001R Retrofit Lid Wrench  
Razor Knife  
Tape Measure  
Pipe Sealant  
Ohm Meter (or multi-meter)

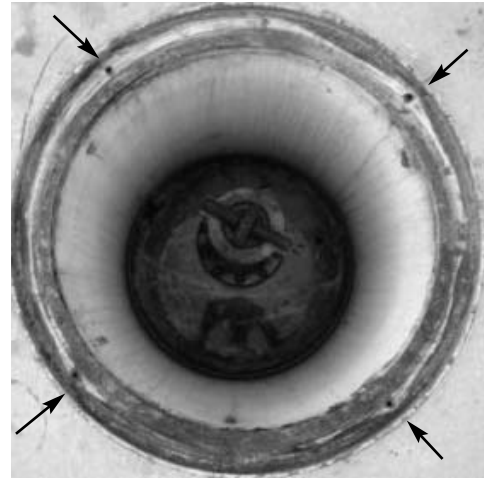
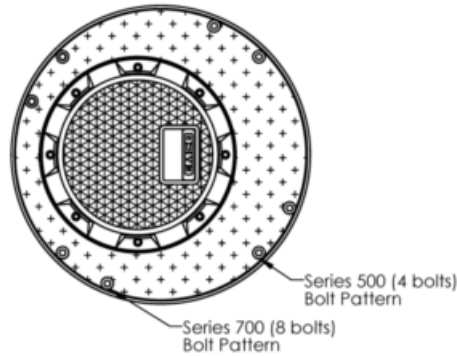

Series 500 (4 bolts) Bolt Pattern

Step 1: Remove existing lid, cap, adapter and OPV or drop tube. Cover or "ball" the riser pipe to prevent debris from entering the tank. Measure the approximate dimension from grade to existing riser pipe (as noted in Step 7), to insure the dimension is **at least 15 1/4"**.

**Measure from the bucket nipple to the tank bottom**, and record this length for use in step 19. (This measurement is used to determine if the existing OPV or drop tube can be reused.)



Step 2: Remove the 4 nuts from underneath the primary rim to loosen. Remove rim. Remove bolts from diamond plate lid, and remove lid. Determine location and wiring method of current sensor.



Step 3: Use the Emco A0081-001H Wrench to remove the existing primary unit. Use of the A0081 Wrench will avoid slipping of the existing primary and prevent breaking the composite "ears".

Step 4: Determine if the original installation allows pulling the new sensor wire to the junction box. This will depend on the cable grommet in the OPW secondary.

If the wire can not be pulled back to the junction box, the wire connections must be made in the existing secondary space using seal-pack type permanent connections.



Step 5: Clean existing rim using a wire brush and putty knife to remove the old gasket and sealants. Blow out bolt holes.

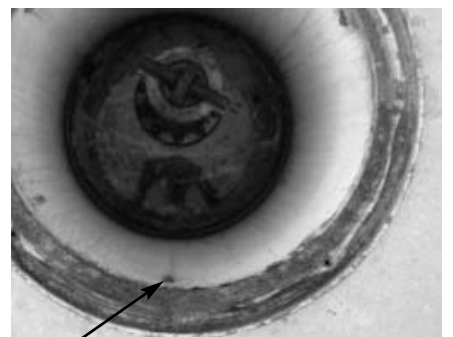

Step 6: Check for interferences which would prevent the Emco lid from seating properly. Remove any obstructions.



# A1004EVR-317SM800/900

Retrofit Double Wall w/Sensor  
Poly Secondary/Stainless Steel Primary

Step 7: Measure from the top of the existing OPW bucket to the top of the riser pipe. Use pipe sealant on internal and external threads of riser extension(s) and install as required to achieve the required height of 15<sup>1</sup>/<sub>4</sub>"-16<sup>1</sup>/<sub>2</sub>". A combination of riser extensions or a coupling and nipple should be used as required to meet the 16<sup>1</sup>/<sub>2</sub>" maximum dimension. Some OPW buckets used 7<sup>1</sup>/<sub>2</sub> gallon primaries that would require a longer nipple to achieve the dimension required.

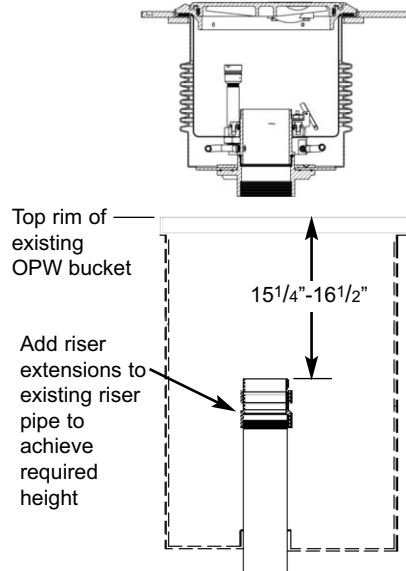

Step 8: Check the tank monitor system to insure it is set up for NC switches.

If the wire can be pulled back to the junction box, remove the current switch wire and pull a fish tape from the junction box to the OPW bucket. Keep the fish tape out of the way and proceed with the bucket installation. If the wire can not be pulled back, put the current switch wire outside the bucket and proceed with the bucket installation.

If using the existing wire, be sure to leave enough length.



Step 9: Temporarily connect the wires and test the sensor by depressing the sensor rocker. You can use an 18" rod. The rocker needs very little force (2-3 lbs.) to activate. Do not force. When the sensor is activated, you need to make sure that the system goes into alarm and this alarm goes off when the sensor button is released.



Step 10: Unhook the temporary connection and put the new switch wire bundle in the primary unit. As the bucket is threaded on the riser, insure the jack has the bucket extended enough to prevent damage to the existing switch wire (or fish tape) as the new diamond plate cover nears the rim. Hand tighten bucket assembly. If the base of assembly is getting close to the wire or fish tape before it starts getting tight, use the jacks to raise the assembly by turning 3 turns counter-clockwise. Continue tightening the assembly by hand.

Step 11: Make the wire connections or pull the new switch wire to the junction box and connect.



# A1004EVR-317SM800/900

Retrofit Double Wall w/Sensor  
Poly Secondary/Stainless Steel Primary

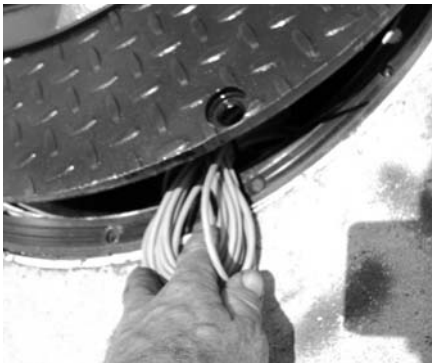

Step 12: Put the wire into the secondary space of the OPW bucket.



Step 13: Use the Emco A0081-001R Retrofit Lid Wrench to tighten bucket onto riser. As the bucket tightens, align outside of lid and one of the two 4-hole bolt patterns in the lid, with four of the existing holes tapped in the rim, (refer to drawing on front page to determine which bolt pattern to use), so that the lid can drop into existing rim.



Step 14: Release the jack by unscrewing 2 nuts from the rim and the 2 bolts that connect them around the center flange adapter. Make sure that the flange o-ring has a smooth (not threaded) surface to seal on. This can be a problem if the bucket is overextended for a deep installation. If this happens, an additional riser extension is needed to correct the riser length.



Step 15: Align the (4) bolt holes and install the (4)  $\frac{5}{16} \times \frac{3}{4}$  bolts (OPW 500) or (4)  $\frac{3}{8} \times \frac{3}{4}$  bolts (OPW 700).

Note: In some cases it may be necessary to unbolt the rim from the lid and rotate the lid into a position where it will drop into existing rim. Re-align bolt holes in rim, lid and existing rim and reassemble.



Step 16: Use a  $\frac{9}{16}$ " socket to tighten the 8 bolts on the flange at the bottom of the stainless steel liner to 15 ft. lbs. Note that the flange bolts must be tightened for the interstitial space to pass leak testing.



Step 17: Install four threaded plugs using a  $\frac{3}{8}$ " Allen Wrench into unused bolt pattern.

Step 18: Measure the distance from the nipple to the tank bottom, and compare with the original measurement from Step 1. If the dimension is more than  $\frac{1}{2}$ " different, measure the overflow prevention valve (OPV) or drop tube length. Subtract the OPV length from the current riser to tank dimension. It is important to measure the OPV or drop tube, and the depth of the tank from the bucket nipple. The riser pipe must be 4-6" from the tank bottom. If it is less than 4", it can cause OPV or flow problems. EPA regulations prohibit greater than 6". If the riser pipe is greater than 6", a new OPV or drop tube should be installed. If the riser pipe is closer than 4" to the bottom, it should be cut so the dimension is 4-6". Reinstall the OPV or drop tube, adapter, cap and spill containment lid.

Step 19: Perform hydrostatic test as per local requirements.

Step 20: Perform secondary integrity test - attached.

## Secondary Integrity Test

Emco Wheaton Retail A1004-210S Double Wall Spill Containment are vacuum tested, both primary and secondary, prior to shipment. To ensure that no damage has incurred during shipment or installation, the following test is a quick, on-site method to verify the integrity of the primary and secondary containments.

### Equipment

Vacuum apparatus w/test adapter 494343, available from Emco Wheaton Retail, p/n A1004-210TEST

Timer

Air supply, 30 psi

### Procedure

1. Remove the dipstick from the inspection port and install the test adapter p/n 494343 (included with the vacuum apparatus) (A).
2. Attach air pressure source to air pressure regulator (B) on vacuum apparatus.
3. Slowly apply vacuum of 30" water column to the interstitial space, by moving the toggle switch (C). Wait 30 seconds. Reapply 30" water column.
4. Ensure switch is in off (center) position, start timer and record remaining vacuum after 1 minute.
5. If the remaining vacuum after 1 minute is 26" water column (1.9" mercury) or greater, both the primary and the secondary containment vessels are tight.
6. If the test fails, allow the bellows to equalize for one minute and repeat test, starting at step 3.
7. If test fails a second time, refer to Emco Wheaton Retail Test Procedures TP-160 and TP-161.
8. Replace components or repair as necessary.

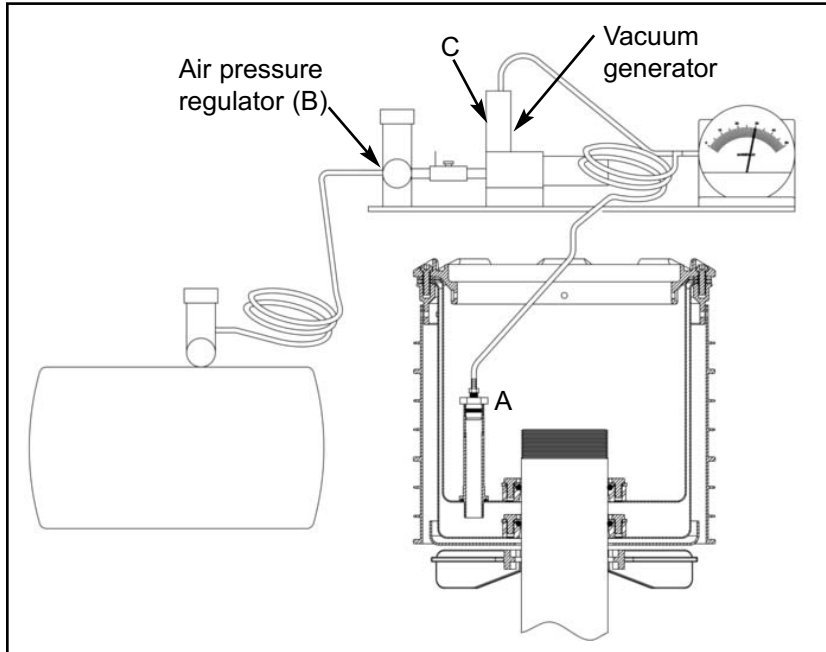

### Maintenance

1. Keep rim/lid and drain areas free of debris.
2. Replace any damaged part at once.

### Replacement Items

494551	Drain Kit
494343	Test Adapter
A1004-001GAGE	EZ gauge
A1004-210TEST	Vacuum Test Apparatus
A1004-316CLID	Lid and Seal



494343 Test Adapter

### Tank Operator Responsibilities

1. Tank operator must ensure that all Federal, Provincial and local codes are being met during the filling of the tank.
2. All operators must be familiar with proper filling procedures.
3. The operator responsible for transferring product to an above ground storage tank must take all reasonable steps to prevent spillage.
4. The delivery hose from the tank's fill pipe must not be disconnected before the hose has been drained completely.
5. When tank vehicles are being unloaded, the vehicle operators must remain (a) in constant view of the transfer nozzle and fill pipe; and (b) in constant attendance at the discharge control valve.