

Step 1: Check installation area for flatness. Fill any voids greater than 1/8".

Step 3: Use a 1/2" masonry bit to drill all 6 holes to a depth of 1-9/16" — 1-5/8".

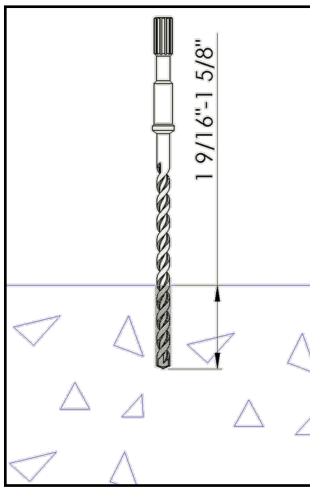

Step 5: Install threaded concrete anchors (EMCO # 574678) into holes with the threaded side facing up. Ensure anchors are flush or slightly below the concrete.

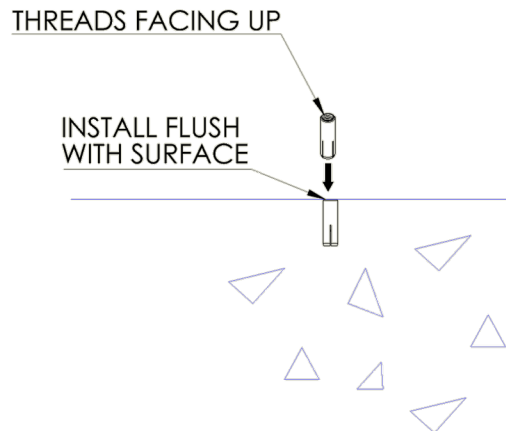

Step 2: Position A0995 rings as desired. Mark installation holes.

Step 4: Clean holes of all debris. Use the following QR Code to see manufacturer installation instructions for typical threaded concrete anchors.



Step 6: Insert the setting tool (EMCO 574679) into the anchor and strike with a hammer until the lip of the setting tool meets the top of the anchor (EMCO 574678).

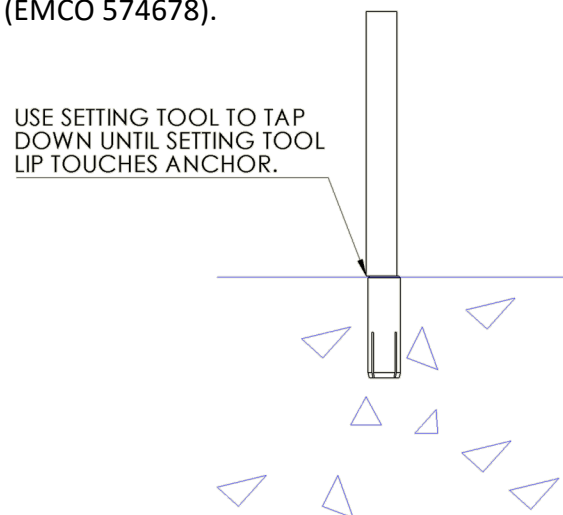

Step 7: Align ID marker with holes.

Step 8: Install provided machine screws through ID marker holes into concrete anchors.

