

A1004EVR-317SS200

Double Wall Stainless Steel Primary/Poly Secondary Spill Containment

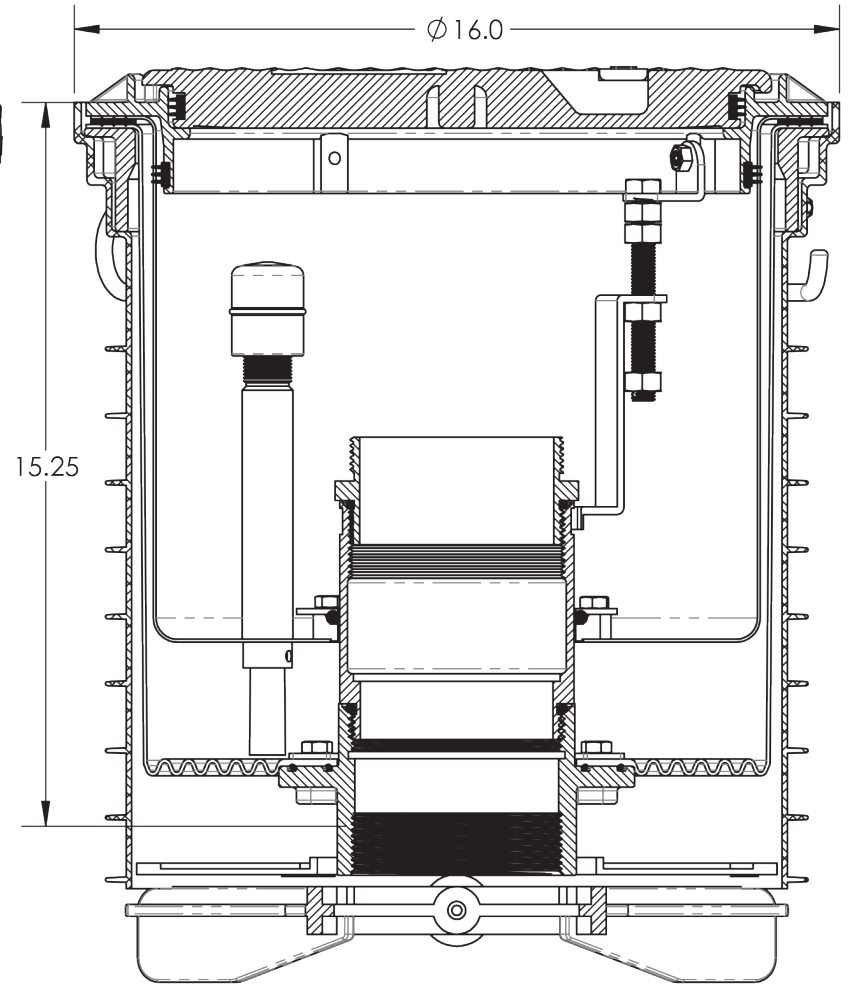
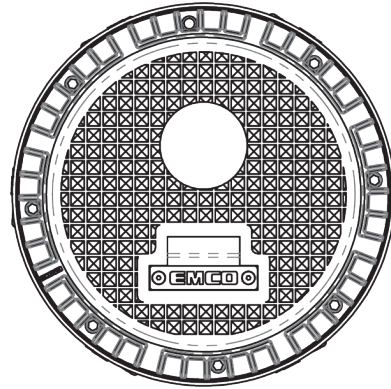

Specifications

- Replaceable; easily repair or replace primary & secondary units from grade without breaking concrete
- 5 gal capacity
- Screw-on
- Weights: Lid 6.6 lbs; Total: 56 lbs

Materials

- Powder coated stainless steel rim
- Composite lid; water resistant with built-in handle, exclusive triple wiper seal and vent valve
- Stainless steel bolts & nitrile seals on primary flange

Application

- Grade level
- Installs 16" on center

Components

- EZ-Gage to monitor interstitial space at a glance
- SST adapter fitting
- SST male adapter coupling

Approvals

- Phase I EVR Executive Order VR-105
- ULC Listed MH21149
- FL DEP # EQ-741
- NC DENR
- MO DNR
- Lid meets H20 Load Rating

Color Variant Part Numbers

Model No.	Rim/Lid	A0996 ID Tag
A1004EVR-317SS200	Black	----
A1004EVR-317SS201	White	Regular
A1004EVR-317SS202	Red	Premium
A1004EVR-317SS203	Yellow	Diesel
A1004EVR-317SS204	Orange	Vapor
A1004EVR-317SS206	Bronze	E85
A1004EVR-317SS207	White	E0
A1004EVR-317SS209	Blue	DEF

© 2019 Emco Wheaton Retail Corporation



EMCO WHEATON RETAIL CORP.
2300 INDUSTRIAL PARK DRIVE
WILSON, N.C. 27893
emcoretail.com

DO NOT SCALE DRAWING-WORK TO DIMENSIONS SHOWN
DIMENSIONS ARE IN INCHES (DIMENSIONS IN BRACKETS ARE IN MILLIMETERS)

UNLESS OTHERWISE SPECIFIED

DECIMALS .X ± .030 .XX ± .015 .XXX ± .005 ANGLES ± 1°
CASTING TOLERANCES TO INDUSTRY STANDARDS
MACHINED SURFACES 125 RMS REMOVE ALL BURRS

THE INFORMATION AND DESIGN DISCLOSED BY AND THE COPYRIGHT IN THIS DRAWING ARE THE PROPERTY OF EMCO WHEATON RETAIL CORP. AND CANNOT BE USED WITHOUT WRITTEN PERMISSION.

DRAWN BY	DATE	USED ON	CASTING NUMBER
CMB	3/16/20	-	-

PART DESCRIPTION

5GAL DW, EVR, REPLACEABLE, 16" CENTER, NPT, N/DRN, SST PRI/POLY SEC, SST FLANGE ADAPTER, SST LID/COMP RIM, SST CLOSE ADAPTER

SIZE	DRAWING NUMBER.	PAGE	REV.
A	A1004EVR-317SS200	1/1	A