

A1004EVR-317S-CM

Double Wall Poly/Poly

Spill Containment

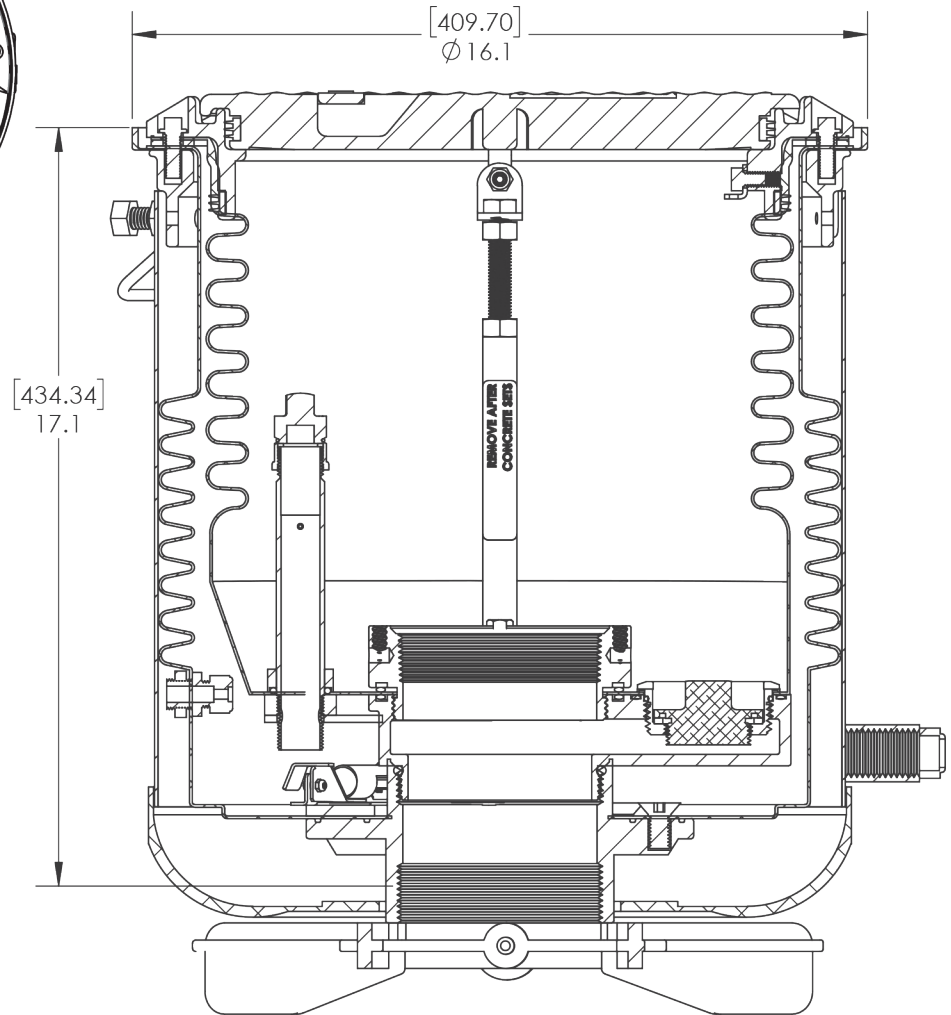
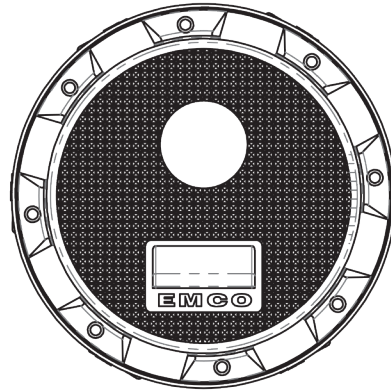

Specifications

- Replaceable; easily repair or replace primary & secondary units from grade without breaking concrete
- 5 gal capacity
- Screw-on
- Weights: Lid: 15.9 lbs; Total: 78 lbs

Materials

- Cast iron rim
- Cast iron lid; water resistant with built-in handle, exclusive triple wiper seal and vent valve

Application

- Grade level
- Installs 16" on center

Components

- Removable drain plug
- Liquid sensor

Approvals

- ULC Listed MH21149
- FL DEP # EQ-741
- NC DENR
- MO DNR
- Lid meets H20 Load Rating

Variant Part Numbers

Model No.	Rim/Lid	Adapter/Cap
A1004EVR-317S-CM	Black	N/A
A1004EVR-317SX-CM*	Black	Fill

*Includes A0030-1245 Fill Swivel Adapter and A0097-005 Fill Cap

©2017 Emco Wheaton Retail Corporation



EMCO WHEATON RETAIL CORP.
2300 INDUSTRIAL PARK DRIVE
WILSON, N.C. 27893
emcoretail.com

DO NOT SCALE DRAWING-WORK TO DIMENSIONS SHOWN
DIMENSIONS ARE IN INCHES (DIMENSIONS IN BRACKETS ARE IN MILLIMETERS)

UNLESS OTHERWISE SPECIFIED

DECIMALS .X ± .030 .XX ± .015 .XXX ± .005 ANGLES ± 1°
CASTING TOLERANCES TO INDUSTRY STANDARDS
MACHINED SURFACES 125 RMS REMOVE ALL BURRS

THE INFORMATION AND DESIGN DISCLOSED BY AND THE COPYRIGHT IN THIS DRAWING ARE THE PROPERTY OF EMCO WHEATON RETAIL CORP. AND CANNOT BE USED WITHOUT WRITTEN PERMISSION.

DRAWN BY	DATE	USED ON	CASTING NUMBER
GEB	7/8/19	N/A	

SYM	REVISIONS	DATE	BY

PART DESCRIPTION
DW SPILL 5 GAL NO DRAIN +SENSOR

SIZE	DRAWING NUMBER.	PAGE	REV.
A	A1004EVR-317S-CM	1/1	A