

A1004EVR-317S7

Double Wall Poly/Poly Spill Containment

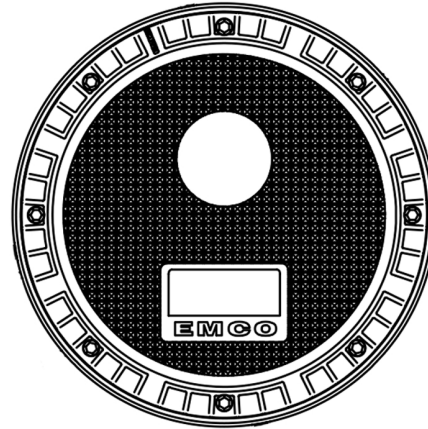

Specifications

- Replaceable; easily repair or replace primary & secondary units from grade without breaking concrete
- 5 gal capacity
- Screw-on
- Weights: Lid: 15.9 lbs; Total: 80 lbs

Materials

- Stainless steel rim
- Cast iron lid; water resistant with built-in handle, exclusive triple wiper seal and vent valve

Application

- Grade level
- Installs 16" on center

Components

- EZ-Gage to monitor interstitial space at a glance
- Removable drain plug

Approvals

- Phase I EVR Executive Order VR-105
- ULC Listed MH21149
- FL DEP # EQ-741
- NC DENR
- MO DNR
- Lid meets H20 Load Rating

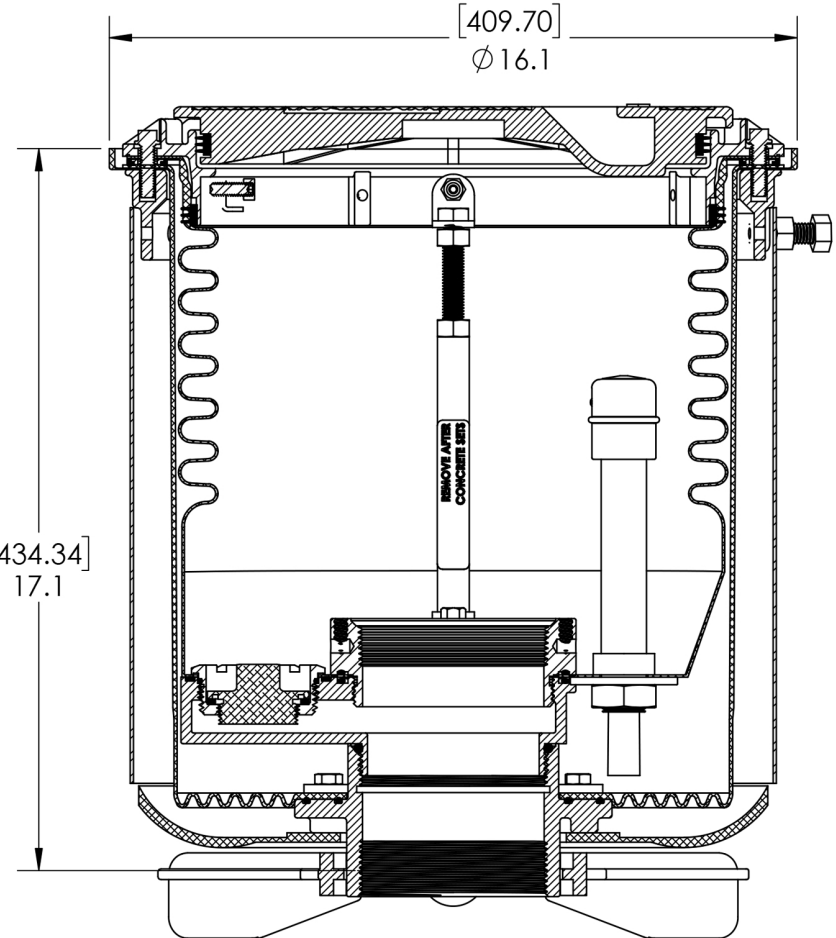

© 2020 Emco Wheaton Retail Corporation

EMCO® WHEATON RETAIL CORPORATION
 2300 INDUSTRIAL PARK DRIVE
 WILSON, NC 27893

DO NOT SCALE DRAWING-WORK TO DIMENSIONS SHOWN
DIMENSIONS ARE IN INCHES (DIMENSIONS IN BRACKETS ARE IN MILLIMETERS)

UNLESS OTHERWISE SPECIFIED

DECIMALS	ANGLES
.X ± .030	.XX ± .015
.XXX ± .005	± 1°

CASTING TOLERANCES TO INDUSTRY STANDARDS MACHINED SURFACES 125 RMS REMOVE ALL BURRS

DRAWN BY GEB	DATE 5/6/20	USED ON
CHECKED BY	DATE	PROJECT NUMBER
APPROVED BY	DATE	SCALE N/A
		WEIGHT

THE INFORMATION AND DESIGN DISCLOSED BY AND THE COPYRIGHT IN THIS DRAWING ARE THE PROPERTY OF EMCO WHEATON RETAIL CORP. AND CANNOT BE USED WITHOUT WRITTEN PERMISSION.

MATERIAL SEE NOTE	CASTING NUMBER
----------------------	----------------

SYM	A	MARKETING	5/6/20	GEB
REVISIONS				

PART NAME
**DOUBLE WALL EVR SPILL CONTAINMENT
 NO DRAIN; SST RIM; CAST LID**

SIZE	DRAWING NUMBER	PAGE	REV
A	A1004EVR-317S7	1 OF 1	A