

A1005-517A

Single Wall Stainless Steel Spill Containment

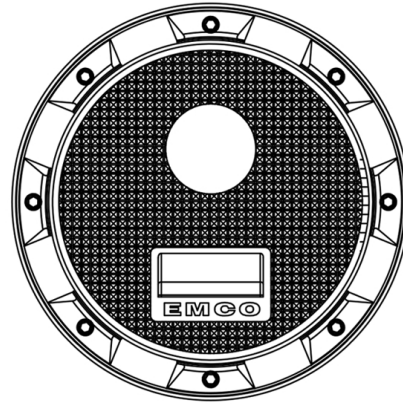

Specifications

- Replaceable; easily repair or replace primary unit from grade without breaking concrete
- 5 gal capacity
- Slip-on
- Weights: Lid: 15.9 lbs; Total: 59 lbs

Materials

- Cast iron rim
- Cast iron lid; water resistant with built-in handle, exclusive triple wiper seal and vent valve
- Nitrile seals

Application

- Grade level
- Installs 16" on center

Approvals

- ULC Listed MH21149
- FL DEP # EQ-524
- Lid meets H20 Load Rating

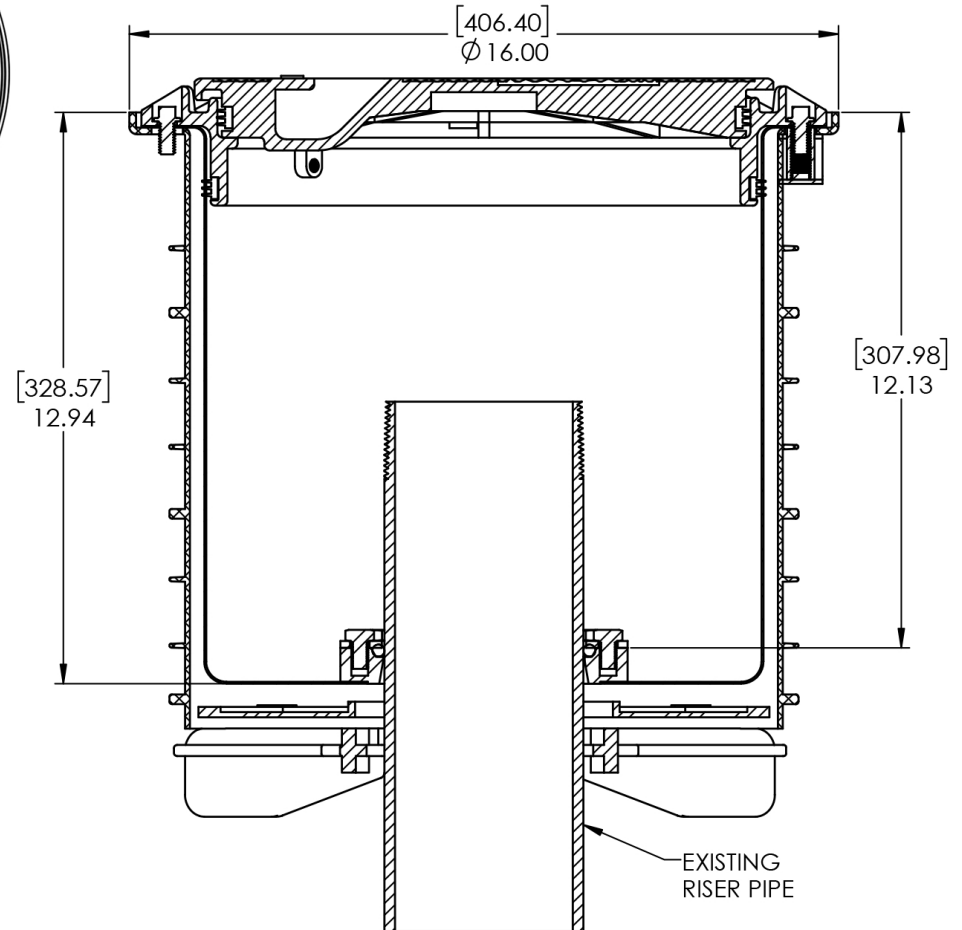

© 2019 Emco Wheaton Retail Corporation

EMCO [®]		EMCO WHEATON RETAIL CORPORATION 2300 INDUSTRIAL PARK DRIVE WILSON, N.C. 27893					
DO NOT SCALE DRAWING—WORK TO DIMENSIONS SHOWN DIMENSIONS ARE IN INCHES (DIMENSIONS IN BRACKETS ARE IN MILLIMETERS)				SYMBOL	REVISIONS	DATE	BY
UNLESS OTHERWISE SPECIFIED		DRAWN BY GEB	DATE 3/21/14	USED ON N/A		PART NAME SST SW SLIPON 5GL	
DECIMALS .X ± .030 .XX ± .015 .XXX ± .005 ± 1°		CHECKED BY		PROJECT NUMBER		SCALE N/A	
ANGLES CASTING TOLERANCES TO INDUSTRY STANDARDS MACHINED SURFACES 125 RMS REMOVE ALL BURRS		APPROVED BY		DATE		WEIGHT	
THE INFORMATION AND DESIGN DISCLOSED BY AND THE COPYRIGHT IN THIS DRAWING ARE THE PROPERTY OF EMCO WHEATON RETAIL CORP. AND CANNOT BE USED WITHOUT WRITTEN PERMISSION.				MATERIAL N/A		CASTING NUMBER	
				SIZE D		DRAWING NUMBER A1005-517A	
						REV. D	