

A1005-517G

Double Wall Stainless Steel Spill Containment

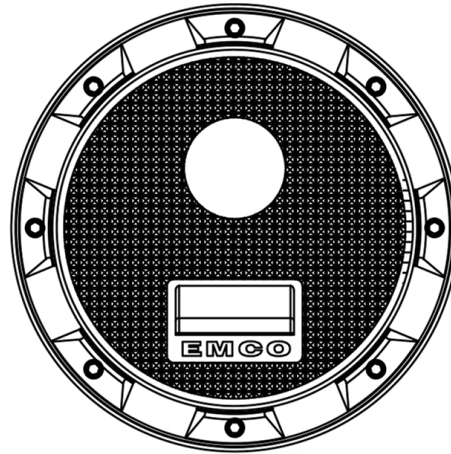

Specifications

- Replaceable; easily repair or replace primary & secondary units from grade without breaking concrete
- 5 gal capacity
- Slip-on
- Weights: Lid: 15.9 lbs; Total: 84.5 lbs

Materials

- Cast iron rim
- Cast iron lid; water resistant with built-in handle, exclusive triple wiper seal and vent valve
- Nitrile seals

Application

- Grade level
- Installs 16" on center

Components

- EZ-Gage to monitor interstitial space at a glance

Approvals

- ULC Listed MH21149
- FL DEP # EQ-524
- Lid meets H20 Load Rating

Variant Part Numbers

Model No.	Rim/Lid	Adapter/Cap
A1005-517G	Black	N/A
A1005-517GV*	Black	Vapor
A1005-517GX**	Black	Fill

*Includes A0076-124S Vapor Swivel Adapter & A0099-002 Vapor Cap

**Includes A0030-124S Fill Swivel Adapter & A0097-005 Fill Cap

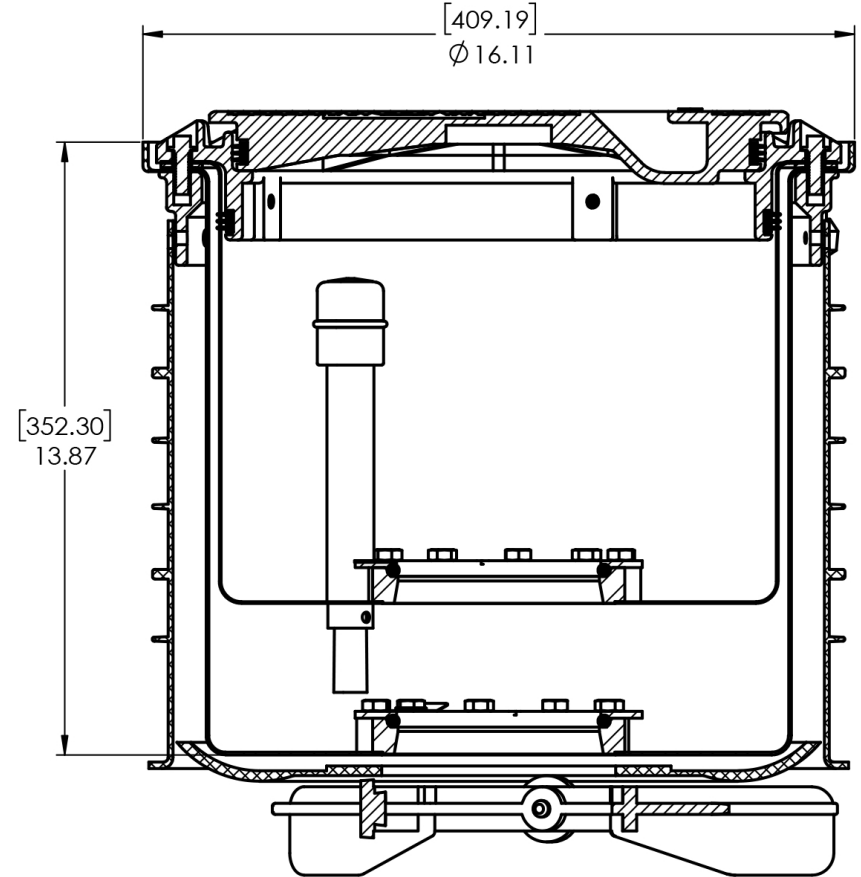

© 2019 Emco Wheaton Retail Corporation

EMCO [®]		EMCO WHEATON RETAIL CORPORATION 2300 INDUSTRIAL PARK DRIVE WILSON, N.C. 27893					
<input type="checkbox"/> DO NOT SCALE DRAWING—WORK TO DIMENSIONS SHOWN DIMENSIONS ARE IN INCHES (DIMENSIONS IN BRACKETS ARE IN MILLIMETERS)				SYM	REVISIONS	DATE	BY
UNLESS OTHERWISE SPECIFIED		DRAWN BY	DATE	USED ON		PART NAME	
DECIMALS ANGLES .X ± .030 .XX ± .015 .XXX ± .005 ± 1°		GEB	5/24/11			DW SST SPILL CONTAINMENT W/GAGE	
CASTING TOLERANCES TO INDUSTRY STANDARDS MACHINED SURFACES 125 RMS REMOVE ALL BURRS		CHECKED BY	DATE	PROJECT NUMBER		SIZE DRAWING NUMBER REV.	
THE INFORMATION AND DESIGN DISCLOSED BY AND THE COPYRIGHT IN THIS DRAWING ARE THE PROPERTY OF EMCO WHEATON RETAIL CORP. AND CANNOT BE USED WITHOUT WRITTEN PERMISSION.		APPROVED BY	DATE	SCALE	WEIGHT	D A1005-517G E	
		MATERIAL		N/A		Casting Number	