

A1005-518AW

Single Wall Stainless Steel Spill Containment

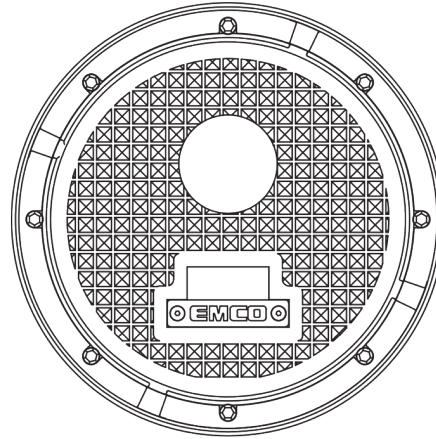

Specifications

- Replaceable; easily repair or replace primary unit from grade without breaking concrete
- 5 gal capacity
- Screw-on
- Weights: Lid: 6.6 lbs; Total: 98 lbs

Materials

- Stainless steel rim with composite color coded segments
- Composite water resistant lid with built-in handle, exclusive triple wiper seal and vent valve

Application

- Grade level
- Installs 16" on center

Approvals

- ULC Listed MH21149
- FL DEP # EQ-524
- Lid meets H20 Load Rating

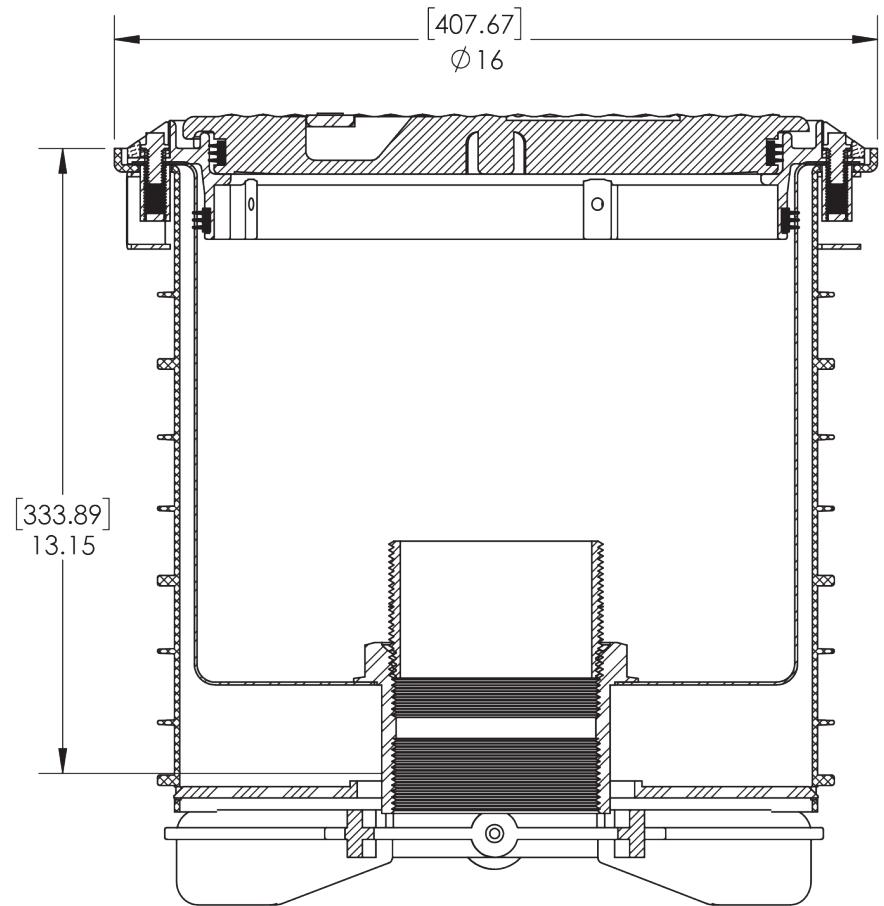

SECTION A-A
SCALE 1 : 4

©2019 Emco Wheaton Retail Corporation



EMCO WHEATON RETAIL CORP.
2300 INDUSTRIAL PARK DRIVE
WILSON, N.C. 27893
emcoretail.com

DO NOT SCALE DRAWING-WORK TO DIMENSIONS SHOWN
DIMENSIONS ARE IN INCHES (DIMENSIONS IN BRACKETS ARE IN MILLIMETERS)

UNLESS OTHERWISE SPECIFIED

DECIMALS	ANGLES
.X ± .030 .XX ± .015 .XXX ± .005	± 1°
CASTING TOLERANCES TO INDUSTRY STANDARDS	
MACHINED SURFACES 125 RMS REMOVE ALL BURRS	

THE INFORMATION AND DESIGN DISCLOSED BY AND THE COPYRIGHT IN THIS DRAWING ARE THE PROPERTY OF EMCO WHEATON RETAIL CORP. AND CANNOT BE USED WITHOUT WRITTEN PERMISSION.

DRAWN BY	DATE	USED ON	CASTING NUMBER
GEB	4/24/20	N/A	

SYM	REVISIONS	DATE	BY
PART DESCRIPTION			
ALL SST SCREW-ON COMPOSITE LID			
SIZE	DRAWING NUMBER.	PAGE	REV.
A	A1005-518AW	1/1	C