

# A1005-518G

## Double Wall Stainless Steel Spill Containment

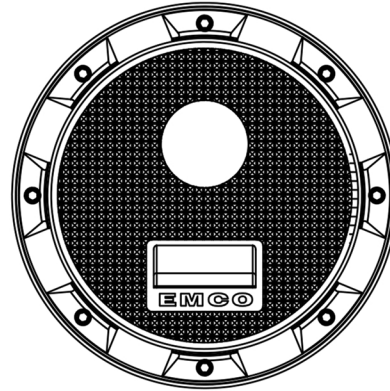

### Specifications

- Replaceable; easily repair or replace primary & secondary units from grade without breaking concrete
- 5 gal capacity
- Screw-on
- Weights: Lid: 15.9 lbs; Total: 85 lbs

### Materials

- Cast iron rim
- Cast iron lid; water resistant with built-in handle, exclusive triple wiper seal and vent valve

### Application

- Grade level
- Installs 16" on center

### Components

- EZ-Gage to monitor interstitial space at a glance

### Approvals

- ULC Listed MH21149
- FL DEP # EQ-524
- Lid meets H20 Load Rating

### Variant Part Numbers

Model No.	Rim/Lid	Adapter/Cap	Sensor
A1005-518G	Black	N/A	No
A1005-518GV*	Black	Vapor	No
A1005-518GX**	Black	Fill	No
A1005-518GX-CM**	Black	Fill	Yes

\*Includes A0076-124S Vapor Swivel Adapter & A0099-002 Vapor Cap

\*\*Includes A0030-124S Fill Swivel Adapter & A0097-005 Fill Cap

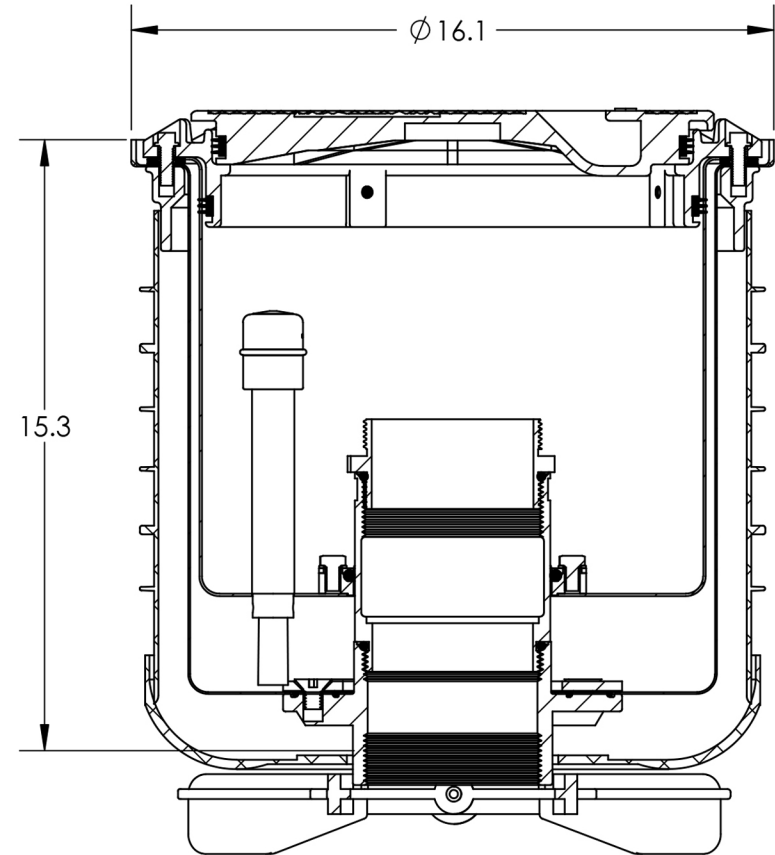

© 2019 Emco Wheaton Retail Corporation



EMCO WHEATON RETAIL CORP.  
2300 INDUSTRIAL PARK DRIVE  
WILSON, N.C. 27893  
emcoretail.com

**DO NOT SCALE DRAWING-WORK TO DIMENSIONS SHOWN**  
DIMENSIONS ARE IN INCHES (DIMENSIONS IN BRACKETS ARE IN MILLIMETERS)

UNLESS OTHERWISE SPECIFIED

DECIMALS .XX ± .015 .XXX ± .005 ANGLES ± 1°  
.X ± .030  
CASTING TOLERANCES TO INDUSTRY STANDARDS  
MACHINED SURFACES 125 RMS REMOVE ALL BURRS

THE INFORMATION AND DESIGN DISCLOSED  
BY AND THE COPYRIGHT IN THIS DRAWING  
ARE THE PROPERTY OF EMCO WHEATON  
RETAIL CORP. AND CANNOT BE USED  
WITHOUT WRITTEN PERMISSION.

DRAWN BY	DATE	USED ON	CASTING NUMBER
GEB	3/9/2011		

REV.	DESCRIPTION	DATE	BY
	PART DESCRIPTION		
	DW THREAD-ON, CAST LID, 5GL SST/SST		
SIZE	DRAWING NUMBER.	PAGE	REV.
A	A1005-518G	1/1	F