

# A1005-518GW

## Double Wall Stainless Steel Spill Containment

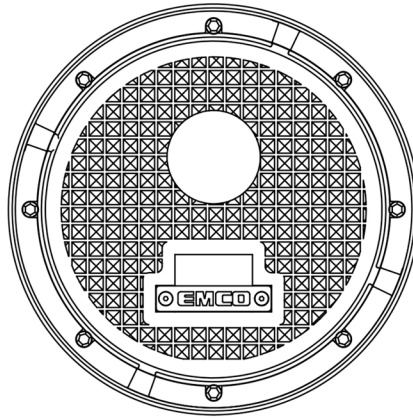

### Specifications

- Replaceable; easily repair or replace primary & secondary units from grade without breaking concrete
- 5 gal capacity
- Screw-on
- Weights: Lid: 6.6 lbs; Total: 98 lbs

### Materials

- Stainless steel rim with composite color coded segments
- Composite water resistant lid with built-in handle, exclusive triple wiper seal and vent valve

### Application

- Grade level
- Installs 16" on center

### Components

- EZ-Gage to monitor interstitial space at a glance
- Welded base

### Approvals

- ULC Listed MH21149
- FL DEP # EQ-524
- Lid meets H20 Load Rating

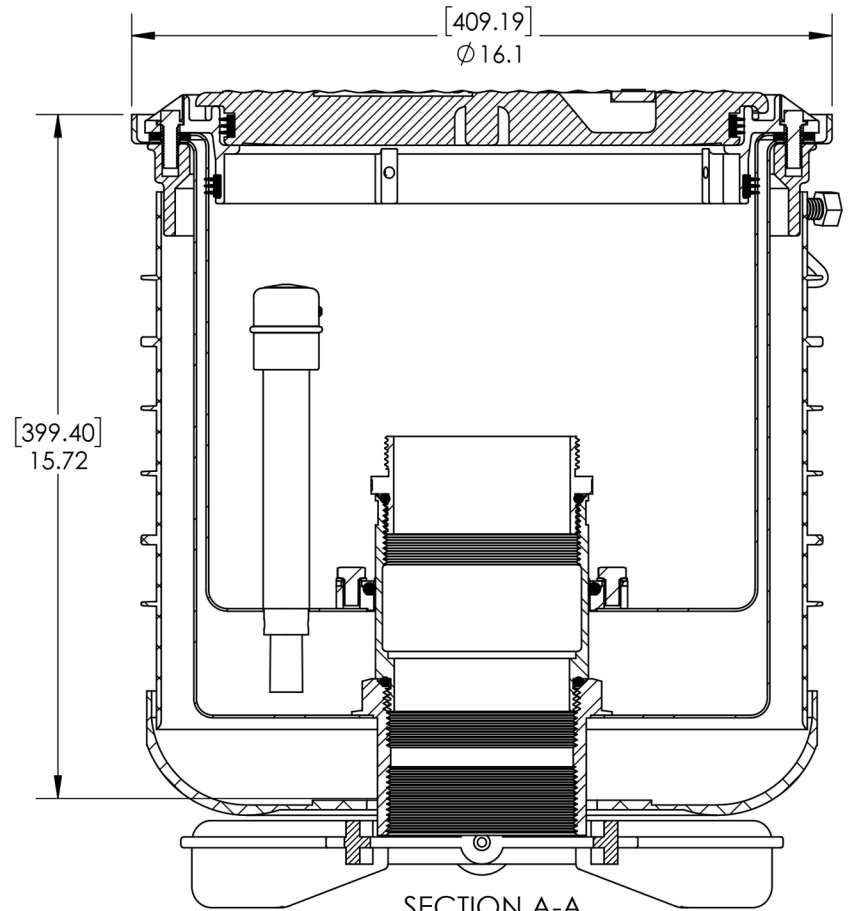

SECTION A-A  
SCALE 1 : 4

© 2017 Emco Wheaton Retail Corporation

		EMCO WHEATON RETAIL CORP. 2300 INDUSTRIAL PARK DRIVE WILSON, N.C. 27893 emcoretail.com							
		<b>DO NOT SCALE DRAWING-WORK TO DIMENSIONS SHOWN</b> DIMENSIONS ARE IN INCHES (DIMENSIONS IN BRACKETS ARE IN MILLIMETERS)							
UNLESS OTHERWISE SPECIFIED DECIMALS .X ± .030 .XX ± .015 .XXX ± .005 ANGLES ± 1° CASTING TOLERANCES TO INDUSTRY STANDARDS MACHINED SURFACES 125 RMS REMOVE ALL BURRS				THE INFORMATION AND DESIGN DISCLOSED BY AND THE COPYRIGHT IN THIS DRAWING ARE THE PROPERTY OF EMCO WHEATON RETAIL CORP. AND CANNOT BE USED WITHOUT WRITTEN PERMISSION.					
DRAWN BY		DATE		USED ON		CASTING NUMBER			
GEB		5/1/2020							
SYM		REVISIONS		DATE		BY			
PART DESCRIPTION									
SST DW THREAD-ON, COMPOSITE LID									
SIZE	DRAWING NUMBER.			PAGE	REV.				
A	A1005-518GW			1/1	F				