

# A1005-905

## Below Grade Stainless Steel Spill Containment

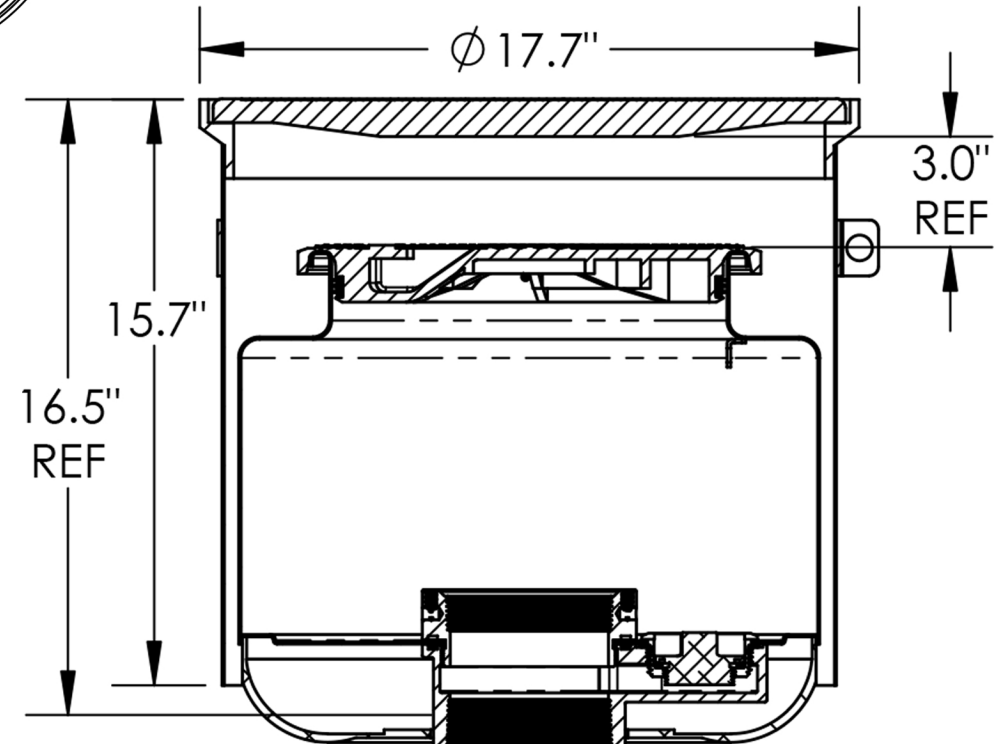
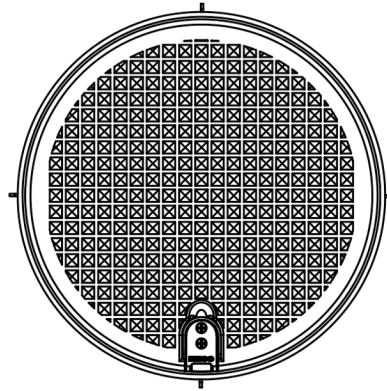

### Specifications

- Replaceable; easily repair or replace from grade without breaking concrete
- 5 gal capacity
- Screw-on
- Weights: Lid: 13.5 lbs; Total: 78.8 lbs

### Materials

- Grade level lid is composite water resistant with built-in handle, exclusive triple wiper seal and vent valve
- Below grade lid is cast iron water resistant with built-in handle, exclusive triple wiper seal and vent valve

### Application

- Below grade

### Components

- Removeable drain plug

### Approvals

- ULC Listed MH21149
- Lid meets H20 Load Rating



EMCO WHEATON RETAIL CORP.  
2300 INDUSTRIAL PARK DRIVE  
WILSON, N.C. 27893  
emcoretail.com

**DO NOT SCALE DRAWING-WORK TO DIMENSIONS SHOWN**  
DIMENSIONS ARE IN INCHES (DIMENSIONS IN BRACKETS ARE IN MILLIMETERS)

UNLESS OTHERWISE SPECIFIED

DECIMALS .X ± .030 .XX ± .015 .XXX ± .005 ANGLES ± 1°  
CASTING TOLERANCES TO INDUSTRY STANDARDS  
MACHINED SURFACES 125 RMS REMOVE ALL BURRS

THE INFORMATION AND DESIGN DISCLOSED BY AND THE COPYRIGHT IN THIS DRAWING ARE THE PROPERTY OF EMCO WHEATON RETAIL CORP. AND CANNOT BE USED WITHOUT WRITTEN PERMISSION.

DRAWN BY	DATE	USED ON	CASTING NUMBER
NPC	6/23/2017		

SYM	REVISIONS	DATE	BY
PART DESCRIPTION			
SPILL CONT. BELOW GRADE 5 GAL SST			
SIZE	DRAWING NUMBER.	PAGE	REV.
A	A1005-905	1/1	F