

A1005-905D

Below Grade Stainless Steel Spill Containment

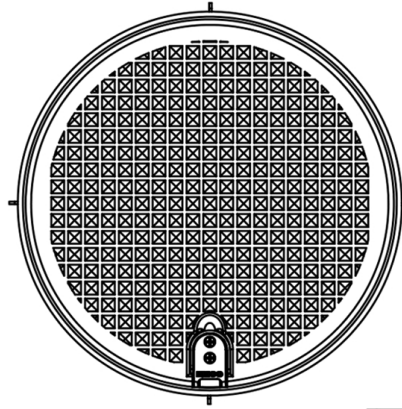

Specifications

- Replaceable; easily repair or replace from grade without breaking concrete
- 5 gal capacity
- Screw-on
- Weights: Lid: 13.5 lbs; Total: 78.8 lbs

Materials

- Grade level lid is composite water resistant with built-in handle, exclusive triple wiper seal and vent valve
- Below grade lid is cast iron water resistant with built-in handle, exclusive triple wiper seal and vent valve

Application

- Below grade

Components

- Drain valve

Approvals

- ULC Listed MH21149
- Lid meets H20 Load Rating

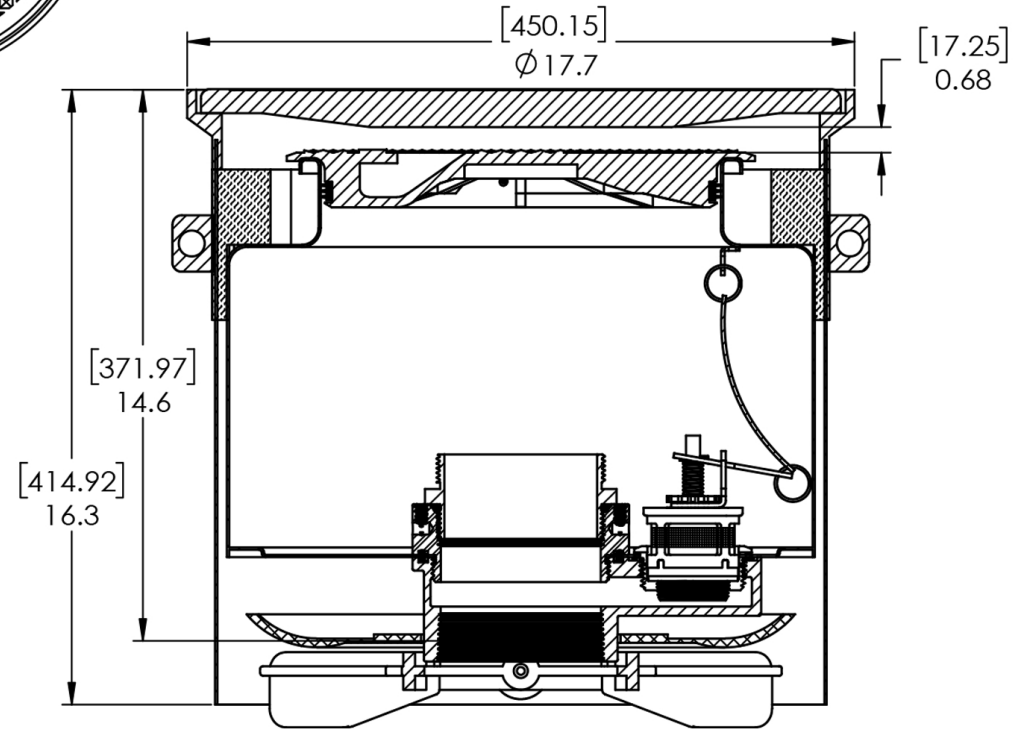

| | | | | | | | |
|---|--|---|----------|----------------|----------------|--|----------------|
| EMCO [®] | | EMCO WHEATON RETAIL CORPORATION 2300 INDUSTRIAL PARK DRIVE WILSON, N.C. 27893 | | | | | |
| <input type="checkbox"/> DO NOT SCALE DRAWING—WORK TO DIMENSIONS SHOWN DIMENSIONS ARE IN INCHES (DIMENSIONS IN BRACKETS ARE IN MILLIMETERS) | | | | SYM | REVISIONS | DATE | BY |
| UNLESS OTHERWISE SPECIFIED | | DRAWN BY | DATE | USED ON | | PART NAME | |
| DECIMALS ANGLES .X ± .030 .XX ± .015 .XXX ± .005 ± 1° | | GEB | 11/19/14 | N/A | | SPILL CONT. BELOW GRADE 5 GAL SST W/DRAIN | |
| CASTING TOLERANCES TO INDUSTRY STANDARDS MACHINED SURFACES 125 RMS REMOVE ALL BURRS | | CHECKED BY | DATE | PROJECT NUMBER | | | |
| THE INFORMATION AND DESIGN DISCLOSED BY AND THE COPYRIGHT IN THIS DRAWING ARE THE PROPERTY OF EMCO WHEATON RETAIL CORP. AND CANNOT BE USED WITHOUT WRITTEN PERMISSION. | | APPROVED BY | DATE | SCALE | WEIGHT | SIZE | DRAWING NUMBER |
| | | MATERIAL | | N/A | | D | A1005-905D |
| | | | | | CASTING NUMBER | | REV. |
| | | | | | | | D |