

A1005-915D

Below Grade Stainless Steel Spill Containment

Specifications

- Replaceable; easily repair or replace from grade without breaking concrete
- 15 gal capacity
- Screw-on
- Weights: Lid: 13.5 lbs; Total: 98 lbs

Materials

- Grade level lid is composite water resistant with built-in handle, exclusive triple wiper seal and vent valve
- Below grade lid is cast iron water resistant with built-in handle, exclusive triple wiper seal and vent valve

Application

- Below grade

Components

- Drain valve

Approvals

- ULC Listed MH21149
- Lid meets H20 Load Rating

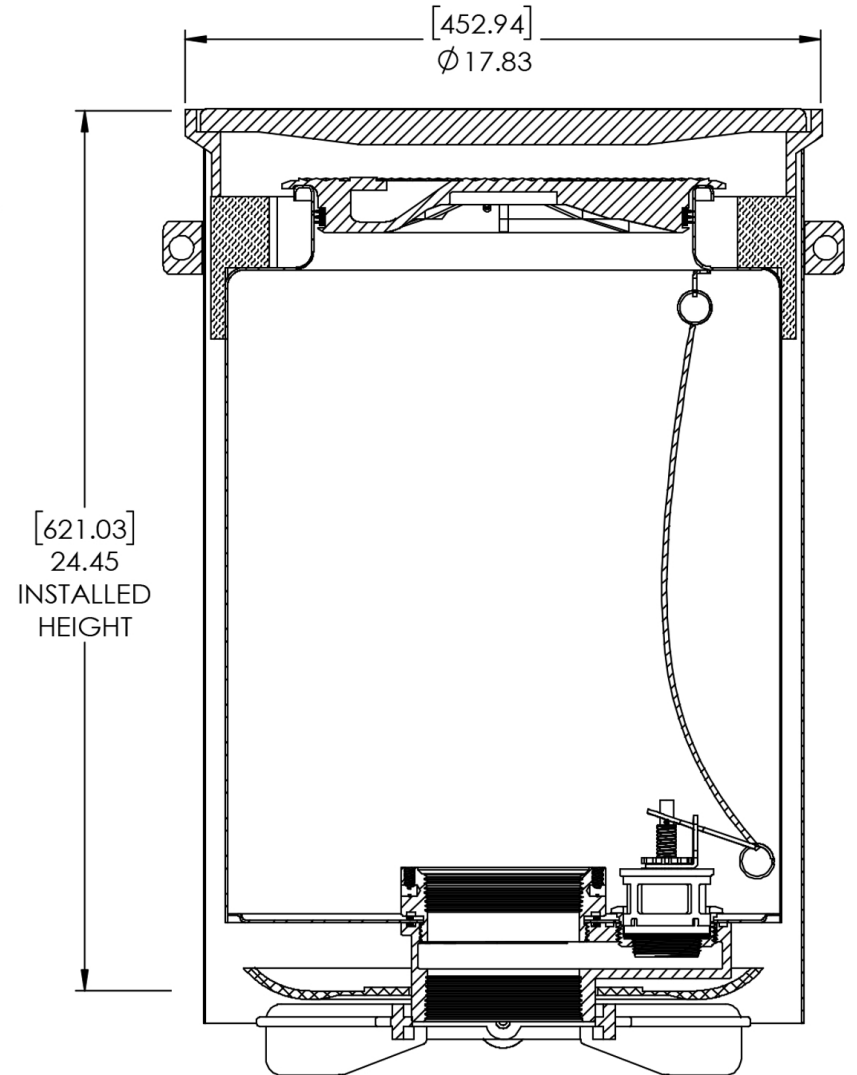
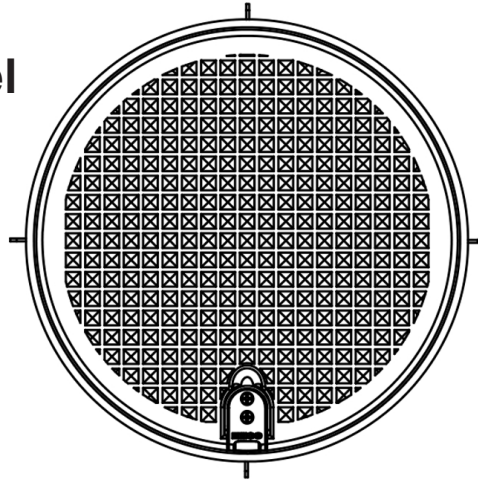

© 2017 Emco Wheaton Retail Corporation

EMCO®

EMCO WHEATON RETAIL CORPORATION
2300 INDUSTRIAL PARK DRIVE
WILSON, N.C. 27893

DO NOT SCALE DRAWING-WORK TO DIMENSIONS SHOWN
DIMENSIONS ARE IN INCHES (DIMENSIONS IN BRACKETS ARE IN MILLIMETERS)

UNLESS OTHERWISE SPECIFIED		
DECIMALS	ANGLES	
.X ± .030	.XX ± .015	.XXX ± .005 ± 1°
CASTING TOLERANCES TO INDUSTRY STANDARDS MACHINED SURFACES 125 RMS REMOVE ALL BURRS		

THE INFORMATION AND DESIGN DISCLOSED BY AND THE COPYRIGHT IN THIS DRAWING ARE THE PROPERTY OF EMCO WHEATON RETAIL CORP. AND CANNOT BE USED WITHOUT WRITTEN PERMISSION.

DRAWN BY GEB	DATE 11/19/14	USED ON N/A
CHECKED BY	DATE	PROJECT NUMBER
APPROVED BY	DATE	SCALE N/A
MATERIAL N/A	WEIGHT	CASTING NUMBER

SYM	REVISIONS	DATE	BY
PART NAME SPILL CONT. BELOW GRADE 15 GAL +DRAIN SST			
SIZE	DRAWING NUMBER.	REV.	
D	A1005-915D	C	